

PART NAME: KNOB SCALE: 1:1 DATE: 3/11/47 DR. BY JVA

DAVIES MOLDING COMPANY
CAROL STREAM, ILLINOIS 60188

P/N 1400-R

THIS DRAWING IS THE PROPERTY OF DAVIES MOLDING COMPANY, IS SUBMITTED SOLELY AS A DESIGN OR ENGINEERING PROJECT. WE ACCEPT NO RESPONSIBILITY WHATSOEVER FOR THE PRACTICAL APPLICATION OF THE PIECES MADE TO THIS DESIGN.

BASE PART 1400-19

SET SCREW I0357

SCALE 2 : 1

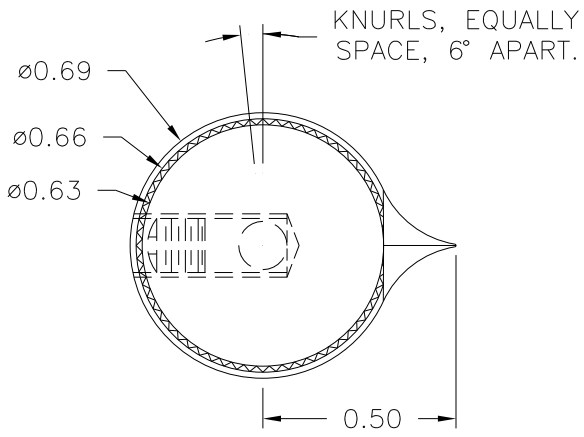

SECTION A-A

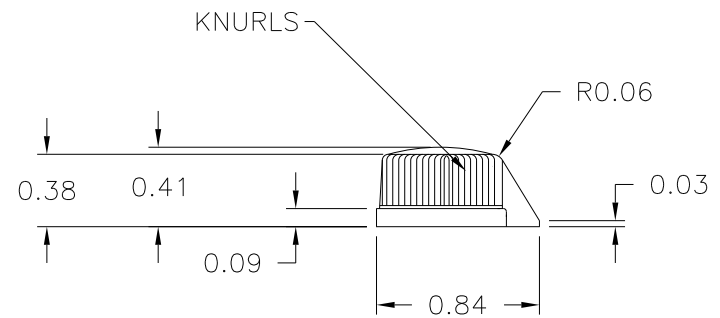

USE #28 DRILL (0.140), #8-32 TAP, #8-32 X 1/4 LG. CUP POINTED, SLOTTED TYPE, SET SCREW I0357 (1).

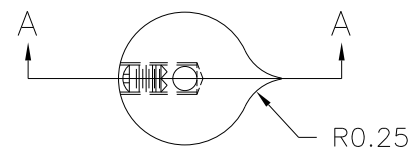
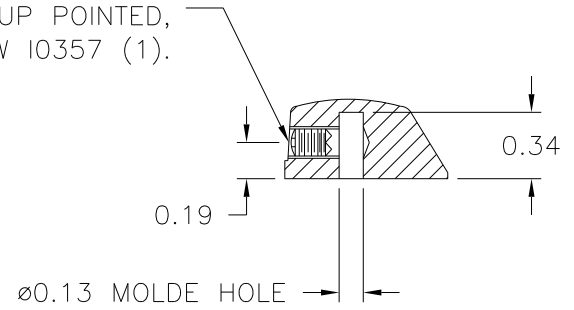

MATERIAL: G.P. PHENOLIC (B11)
COLOR: BLACK

TOLERANCES: UNLESS OTHERWISE SPECIFIED	DO NOT SCALE DRAWING			
DECIMALS: X.XXX ± .005 X.XX ± .015	MM: X.XX ± 0.15MM X.X ± 0.4MM	-	UPDATED/HAD TOOLBOX	ST 10/10/2000
FRACTIONS ± 1/64	ANG. ± 1°	-	CAD/REDRAWN	HD 2/6/97
CHANGES				