

THERMOPILE TYPE INFRARED SENSOR

THERMOPILE

Thermopile type Infrared sensor
utilizing own silicon micromachining
technology.

Applications: Tympanic thermometer
Microwave oven
Non contact temperature measurement

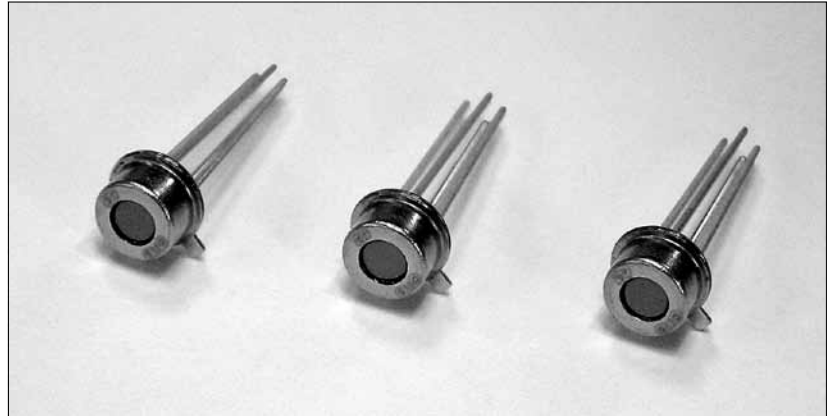

Part number

Part No.	type	Thermistor
10TP583T	TO18	Built-in

Dimensions

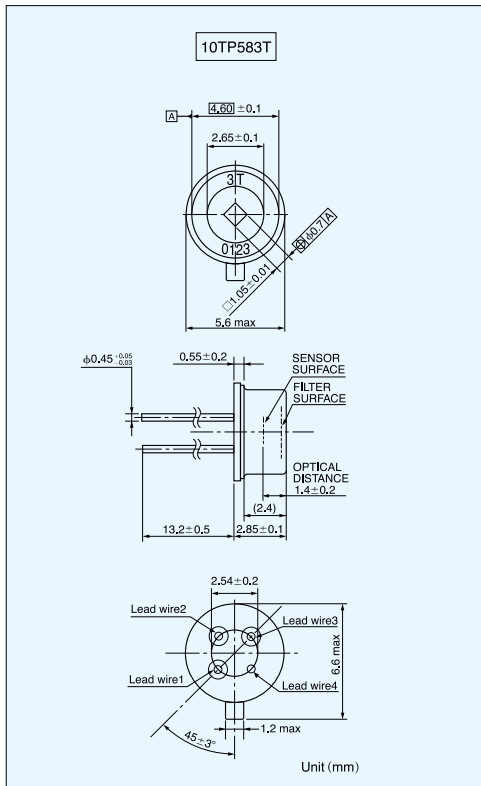

Ratings

Parameters	Value	Unit	Conditions
	10TP583T		
Sensitive area	1.05×1.05	mm ²	Size of Absorbing Film
*1 Responsivity	15±30%	V/W	
*1 Output Voltage	200±30%	μV	
*2 Output Voltage	1.00±30%	mV	
*1 Temperature Coefficient of Responsivity	0.02±0.02	% / °C	Reference
Thermopile Resistance	65±30%	kΩ	
Temperature Coefficient of Thermopile Resistance	±0.1	% / °C	
Johnson Noise Voltage	33	nV / √Hz	Johnson Noise r.m.s., 298K 1Hz Typical
*1 S/N Ratio	75.7	dB	Output Voltage/Johnson Noise, Typical
*1 Noise Equivalent Power	2.2	nW/ Hz ^{1/2}	Typical
*1 Specific Detectivity	4.7×10 ⁷	cm·Hz ^{1/2} / w	Typical
Time Constant	15	ms	Typical
Operating Temperature range	-20~+100	°C	
Storage Temperature range	-40~+100	°C	
Filter Range	Cut on 5	μm	Standard
Field of View	±50	deg.	Incident Angle to Achieve 50% Responsivity
Insulation Resistance	≥500	MΩ	Application of DC25V
Sealing	≤1×10 ⁻⁹	Pa·m ³ / s	
*3 Thermistor Resistance Value	100±3%	kΩ	Rated Zero-power Resistance Value at 25°C
*3 Thermistor B-Value	3435±0.7%	K	
*3 Thermistor Rated Power	0.5	mW	at 25°C

Connections

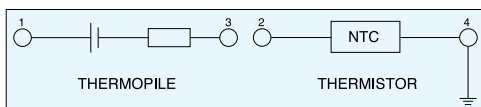

*1 Test Condition
Blackbody Temperature : 500K
Sensor-Blackbody Distance : 100mm
Sensor Temperature : 298K
Aperture size : φ12.7mm

*2 Test Condition
Blackbody Temperature : 310K
Sensor Temperature : 298K

*3 Built-in Type