

90-2200

A

A .01 DIA. OF WIRE RELEASE WAS 66EL 501  
 B .070 DIA. BY 31-6630-10  
 C SQUARE, TERM. HOLES WERE ROUND  
 D WIRE WAS #18  
 E NOTE REVISED & NOTE ADDED. TERM. HOLES CHG'D  
 F NOTE FOR SINGLE POLE SWITCHES ADDED. SWR 6630-10 DIM. 375 ± .032 WAS 372 ± .032  
 G ADDED 1.960 MAX. DIM. 10

REVISIONS	702A500001
TOP OF COVER	G.S. 1/14/48
ADDED 33° ± 4°	9300102
.675 ± .015	WL JW 11/9/89
50° ± 4° WAS 33° ± 4°	9300110
.843 ± .015 WAS .675 ± .015	

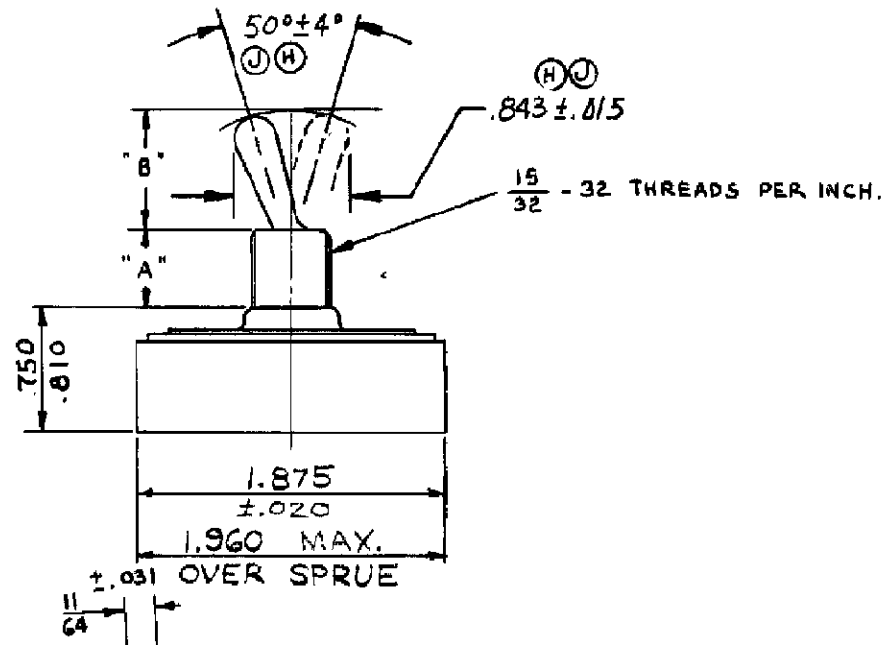
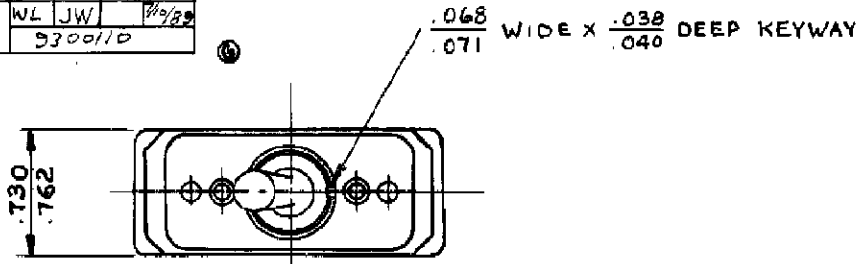

THESE HOLES FOR  
 RELEASE TOOLS.  
 RELEASE TOOLS TO BE  
 OF HARDENED STEEL.  
 .072 — #18 WIRE  
 .083 — #16 WIRE  
 .093 — #14 WIRE

3/32 SQ. HOLES TO ACCEPT #18, #16 OR #14  
 STRANDED TIN DIPPED WIRE LEADS SKINNED  
 .375 ± .032.  
 RECOMMEND NOT INSERTING #18 WIRE  
 AFTER HAVING REMOVED  
 #14 WIRE.

TERMINAL LEADS  
 TO BE PLUGGED IN  
 THIS END OF  
 SWITCH FOR  
 SINGLE POLE  
 SWITCHES

15/32"	.661-.733
11/32"	.668-.740
BUSHING LENGTH "A"	DIM. "B"

BY 31-6630-10  
 BY 31-6630-10A122

TITLE				DIMENSIONS FOR TOOL HANDLE SWITCH			
SUP'S. NON-INTERCHANGEABLE	FIRST ASSEM. WHERE LISTED	DR.	CHK.	INDEX	YES	NO	
	D 90-2195	G. F. LAMBOY	3-15 57	L. SOTO	529.57		
BUR'D. BY NON-INTERCHANGEABLE	APR.						
CUTLER-HAMMER INC. MILWAUKEE			NEW YORK		A		90-2200