

HONEYWELL
PART NUMBER
RPNS090GA1A21X

| | | | |
|-----|-----------------|------------|-------|
| REV | CHANGE DOCUMENT | CHANGED BY | CHECK |
| A | 0040247 | VS 23JUN08 | BLR |

| Technical Data | |
|--|-----------------------------|
| Function | Angular Sensor |
| Sensor principle | Contact-free, Hall effect |
| Measuring range | 90° |
| Mechanical end stop | None |
| Supply voltage | 10 – 30 VDC |
| Current consumption max. | 20 mA |
| Output signal | |
| Angle /° | Output signal |
| L (45°) | 0,5 VDC |
| 0° | 2,5 VDC |
| R (45°) | 4,5 VDC |
| Delay of the output signal | approx. 3 ms |
| Reverse polarity protection | Yes |
| Output | 24h short –circuit proof |
| EMC | 200V/m acc. to ISO 11452-3 |
| Ambient conditions | |
| Operating temperature: | - 40°C bis + 85°C |
| Temperature range (storage) | - 40°C bis + 125°C |
| protection class | IP67 acc. to DIN 40050 |
| Tightening torque of the mounting screw max. | 2,5 Nm ± 0,5 Nm |
| Accuracy | ±1,6% / 2mV/° |
| Hysteresis | None |
| Linearity | ±2° |
| Cycles of rotation | 30 x 10 ⁶ cycles |

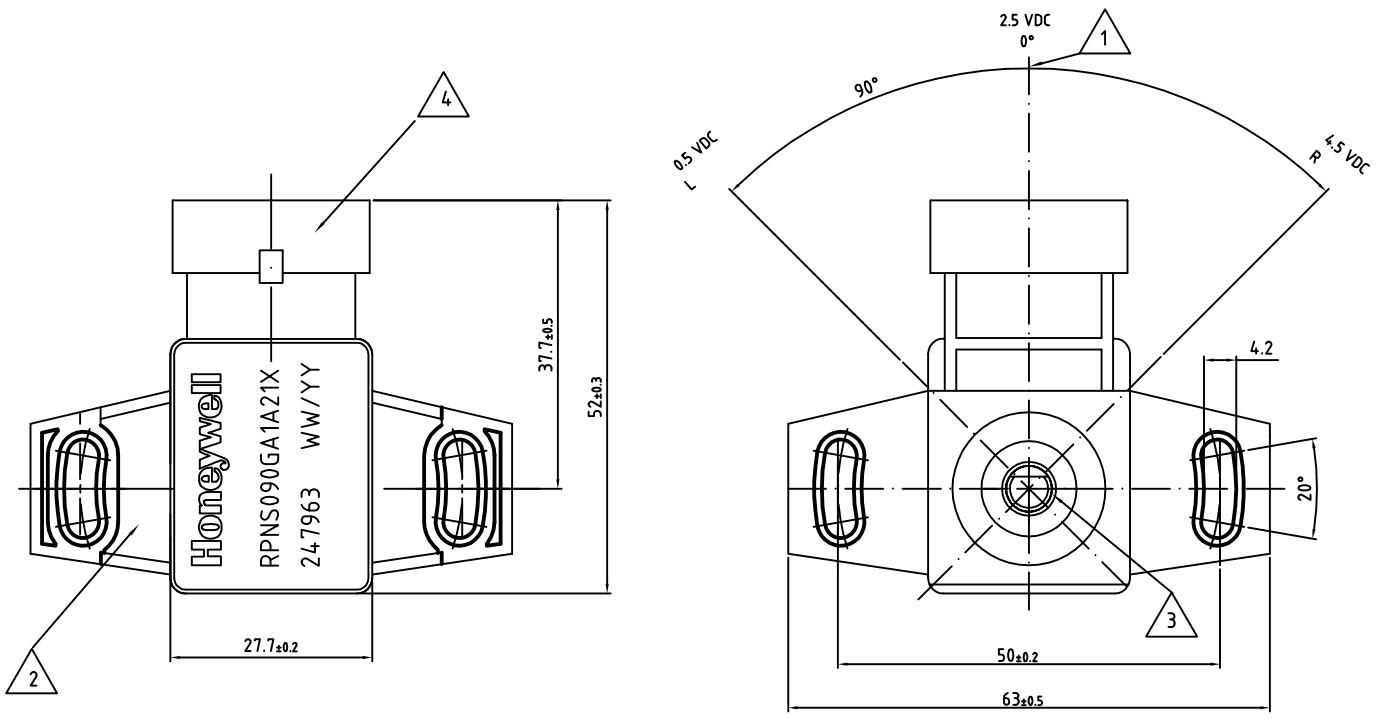

| | | | |
|-----------|-----------|--------|-------|
| φ6 | q6 | -0.004 | 5.996 |
| | | -0.012 | 5.988 |
| φ2 | H11 | +0.06 | 2.06 |
| Dimension | Tolerance | | |

- 1 Zero point
- 2 Housing Material PA66
- 3 Shaft Material Stainless Steel
- 4 Tab Connector acc. to AMP Superseal 1.5 Series 282105 Shall mate with Receptacle Connector 282087-1

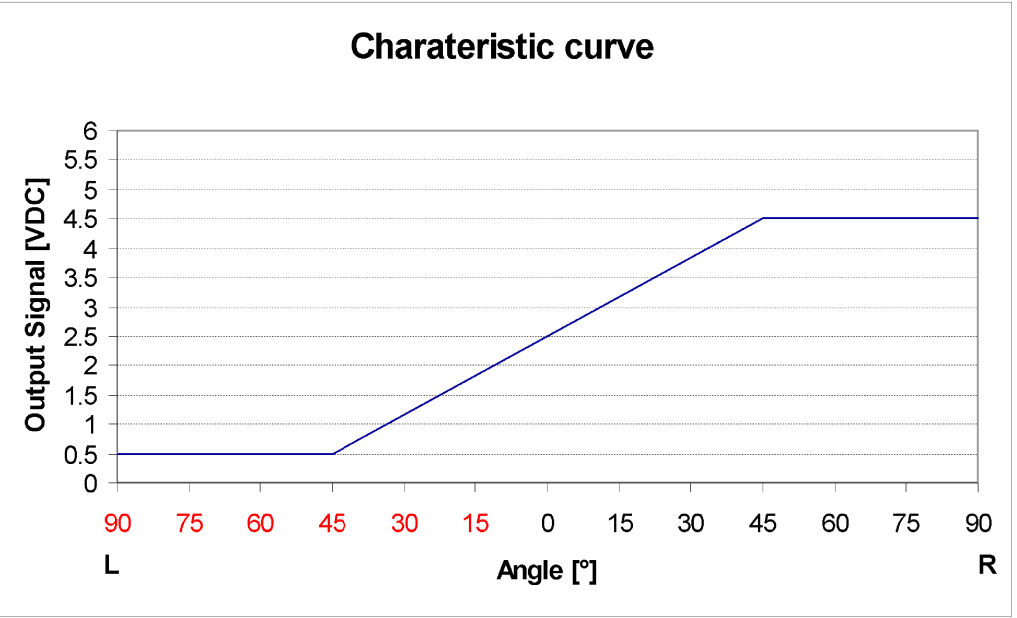
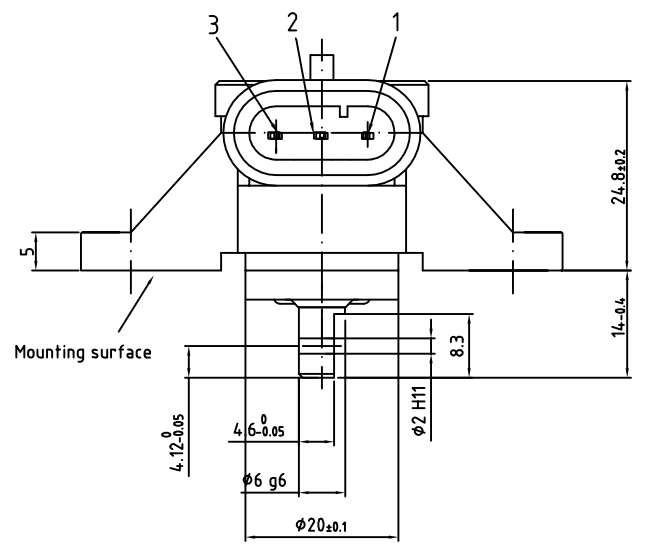

| Pin configuration | |
|-------------------|--------------|
| 1 | GND |
| 2 | Ub 10-30 VDC |
| 3 | 0.5-4.5 VDC |

DESIGN UNITS: MM
TOLERANCES UNLESS NOTED:
GEOMETRICAL TOLERANCE ACCORDING TO DIN ISO 1101
GENERAL TOLERANCES ACCORDING TO DIN 16901-130B

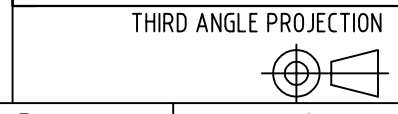

| | | |
|--|-----|-----------|
| DRAWN | JA | 18 JUN 08 |
| CHECK | JLH | 18 JUN 08 |
| THIS DRAWING COVERS A PROPRIETARY ITEM AND IS THE PROPERTY OF HONEYWELL. THIS DRAWING IS NOT TO BE COPIED OR USED WITHOUT THE PERMISSION OF HONEYWELL. | | |
| INTERPRET PER ASME Y14.5M-1994 OTHER HONEYWELL ENGINEERING STANDARDS MAY APPLY | | |

| | | | |
|------------------------------|------|----------------|-----|
| Honeywell | | | |
| TITLE ANGULAR SENSOR ±45° | | | |
| SIZE | TYPE | DRAWING NAME | REV |
| A3 | I | RPNS090GA1A21X | A |