

UNCONTROLLED DOCUMENT

SC:0.25

PART NUMBER

REV.

SSF-LXHM140SYSUGW

PRELIMINARY IN P/N DIR

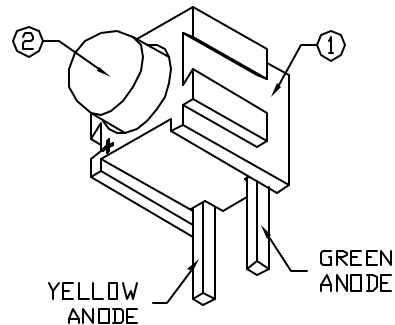
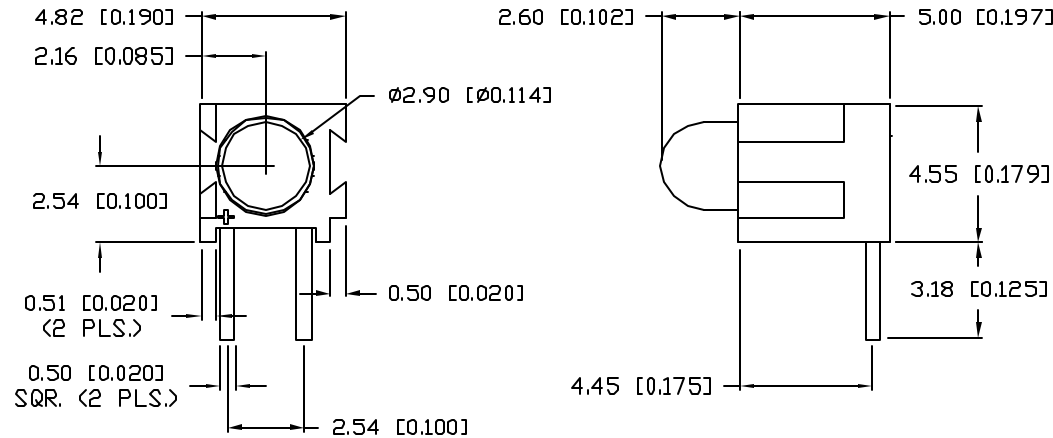

ELECTRO-OPTICAL CHARACTERISTICS $T_A=25^\circ\text{C}$ $I_f=20\text{mA}$

PARAMETER	MIN	TYP	MAX	UNITS	TEST COND
PEAK WAVELENGTH		590 (YELLOW)		nm	
		574 (GREEN)		nm	
FORWARD VOLTAGE (Y/G)		2.0/2.2	2.5/2.6	V _f	
REVERSE VOLTAGE	5.0			V _r	I _f =100 μ A
AXIAL INTENSITY (Y/G)		60		mcd	I _f =20mA
VIEWING ANGLE		60		2x θ_{max}	
EMITTED COLOR:	YELLOW/GREEN				
EPOXY LENS FINISH:	MILKY WHITE DIFFUSED				

LIMITS OF SAFE OPERATION AT 25°C

PARAMETER	COLORS	MAX	UNITS
PEAK FORWARD CURRENT*		150	mA
STEADY CURRENT	(Y/G)	30/25	mA
POWER DISSIPATION		105	mW
DERATE FROM 25°C		-1.6	mW/°C
OPERATING, STORAGE TEMP.		-40 TO +85	°C
SOLDERING TEMP.		+260	°C
2.0mm FROM BODY			3 SEC. MAX

* $t < 10\mu\text{s}$

NOTES:

1. SSH-LXHM140, MATING HOLDER, BLACK.
2. SSL-LX3044SYSUGW, BICOLOR LED.

UNCONTROLLED DOCUMENT

*UNLESS OTHERWISE SPECIFIED TOLERANCES PER DECIMAL PRECISION ARE: X=±1 (±0.039), XX=±0.5 (±0.020), XXX=±0.25 (±0.010), XXXX=±0.127 (±0.005). LEAD SIZE=±0.05 (±0.002), LEAD LENGTH=±0.75 (±0.030). MIN= +DECIMAL PRECISION -0.00 MAX.= +0.00 -DECIMAL PRECISION

REV.

PART NUMBER

SSF-LXHM140SYSUGW

CONFIDENTIAL INFORMATION

THE INFORMATION CONTAINED IN THIS DOCUMENT IS THE PROPERTY OF LUMEX INC. EXCEPT AS SPECIFICALLY AUTHORIZED IN WRITING BY LUMEX INC., THE HOLDER OF THIS DOCUMENT SHALL KEEP ALL INFORMATION CONTAINED HEREIN CONFIDENTIAL AND SHALL PROTECT SAME IN WHOLE OR IN PART FROM DISCLOSURE AND DISSEMINATION TO ALL THIRD PARTIES.

RELIABILITY NOTE

OUR MANY YEARS OF EXPERIENCE DATA ACCUMULATION INDICATE THAT SOLDER HEAT IS A MAJOR CAUSE OF EARLY AND FUTURE FAILURE. PLEASE PAY ATTENTION TO YOUR SOLDERING PROCESS.



290 E. HELEN ROAD
PALATINE, IL 60067-6976
PHONE: +1.847.359.2790
US WEB: www.lumex.com
TW WEB: www.lumex.com.tw

T-3mm (T-1) MATING, RIGHT ANGLE FAULT INDICATOR,
AlInGaP YELLOW/GREEN BICOLOR LED, MILKY WHITE DIFFUSED.

DRAWN BY:

CHECKED BY:

APPROVED BY:

DATE: 5.29.02

CT

PAGE: 1 OF 1

SCALE: N/A