

LTC2400

24-Bit Micropower No Latency Delta Sigma ADC

DESCRIPTION

This demonstration board features the LTC[®]2400, a 24-bit high performance $\Delta\Sigma$ analog-to-digital converter (ADC). The LTC2400 combines exemplary DC accuracy (INL ± 2 ppm, 2.5 μ V offset, 0.3ppm noise) with an easy to use SPI interface in a SO-8 package.

DC573 is a member of Linear Technology's QuikEval[™] family of demonstration boards. It is designed to allow easy evaluation of the LTC2400 and may be connected directly to the target application's analog signals while using the DC590 USB serial controller board and supplied

software to measure performance. The exposed ground planes allow proper grounding to prototype circuitry. After evaluating with LTC's software, the digital signals can be connected to the end application's processor/controller for development of the serial interface.

Design files for this circuit board are available at <http://www.linear.com/demo>

LT, LT, LTC, LTM, Linear Technology and the Linear logo are registered trademarks and QuikEval is a trademark of Linear Technology Corporation. All other trademarks are the property of their respective owners.

BOARD PHOTO



QUICK START PROCEDURE

Connect DC573 to a DC590 USB serial controller using the supplied 14-conductor ribbon cable. Connect DC590 to host PC with a standard USB A/B cable. Run the evaluation software supplied with DC590 or downloaded from www.linear.com/software. The correct program will be loaded automatically. Click the COLLECT button to start reading

the input voltage. Details on software features are documented in the control panel's help menu.

Tools are available for logging data, changing reference voltage, changing the number of points in the strip chart and histogram, and changing the number of points averaged for the DVM display.

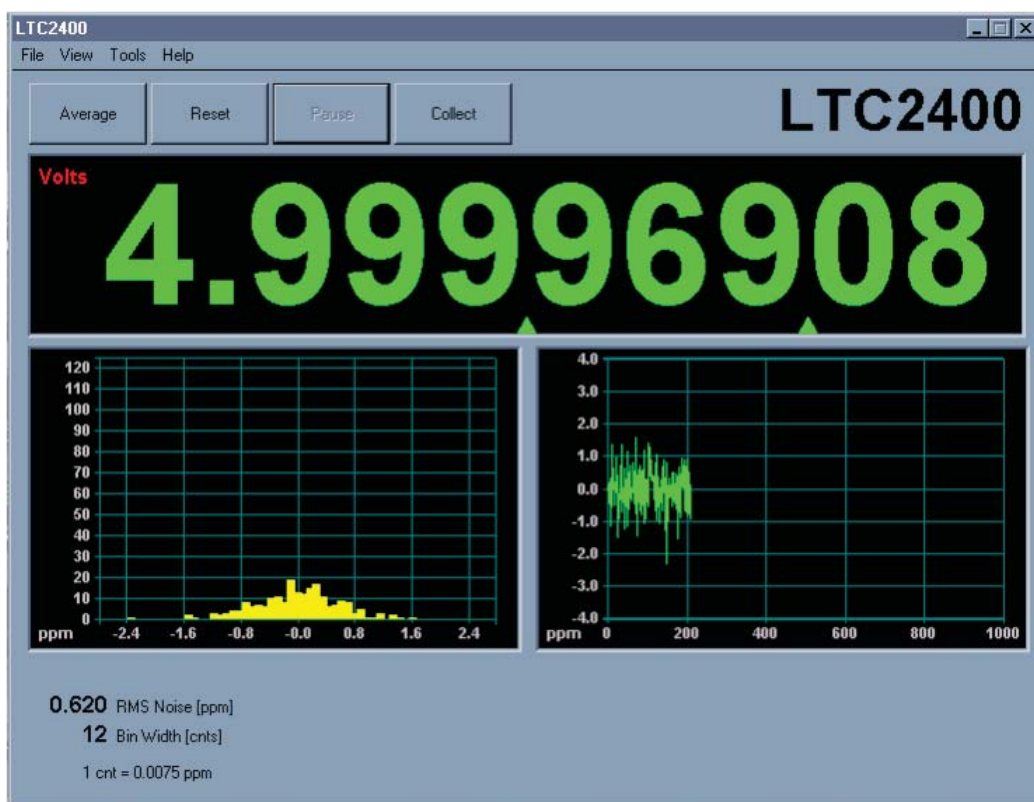

HARDWARE SETUP

JUMPERS

JP1: Select the reference source, either external or 5V from the onboard LT1236 reference (default).

JP2: Select the line rejection frequency, either 50Hz or 60Hz (default.) This jumper must be removed if applying an external conversion clock to the F_0 turret post.

JP3: Trigger mode, either normal (default) or externally triggered.

JP4: Trigger input signal. Pin 1 is a 5V logic signal, pin 2 is ground. When triggered mode is selected on JP3, a rising edge starts a new conversion.

CONNECTION TO DC590 SERIAL CONTROLLER

J1 is the power and digital interface connector. Connect to DC590 serial controller with supplied 14-conductor ribbon cable.

ANALOG CONNECTIONS

Analog signal connections are made via the row of turret posts along the edge of the board. Also, if you are connecting the board to an existing circuit, the exposed ground

planes along the edges of the board may be used to form a solid connection between grounds.

GND: Ground turrets are connected directly to the PCB's ground planes.

V_{CC}: This is the supply for the ADC. Do not draw any power from this point. External power may be applied to this point after disabling the switching supply on DC590. If the DC590 serial controller is being used, the voltage must be regulated 5V only, as the isolation circuitry will also be powered from this supply. Refer to the DC590 quick start guide for more details.

V_{REF}: This turret is connected to the LTC2400 reference pin. If the onboard reference is being used, the reference voltage may be monitored from this point. An external ground referred reference may be connected to this terminal if JP1 is configured for external reference.

V_{IN}: Input voltage to the LTC2400. The absolute range of the input voltage is $GND - 0.3V$ to $V_{CC} + 0.3V$. The range for a valid conversion is $GND - 0.125 \cdot V_{REF}$ to $1.125 V_{REF}$. See Figure 1.

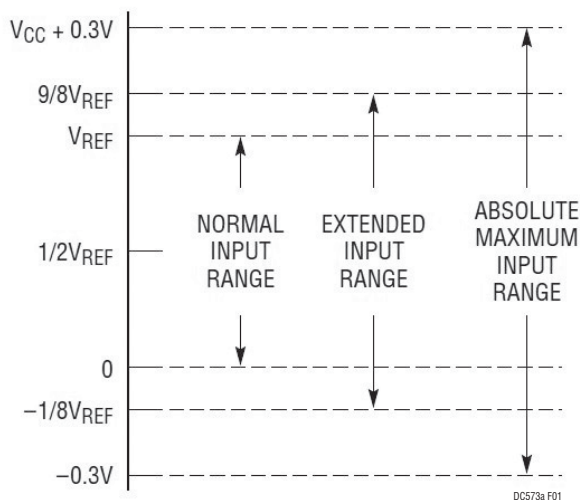

Figure 1. LTC2400 Input Range

EXPERIMENTS

OFFSET

Short V_{IN} to ground. The offset is typically less than 0.5ppm of V_{REF} , with a maximum of 2ppm of V_{REF} (2.5 μ V typical and 10 μ V max when using a 5V reference.)

FULL SCALE

Short V_{IN} to V_{REF} . The full-scale error is typically less than 4ppm, with a maximum of 10ppm of V_{REF} (20 μ V typical and 50 μ V max when using a 5V reference.)

RMS NOISE

Short V_{IN} to ground. The RMS noise display indicates the RMS noise based on a number of samples that can

be set in the software options. With the input shorted to ground, the indicated noise is the noise of the LTC2400 input. When another source is connected, the indicated noise is the total noise of the LTC2400 and the source.

The USB controller powers the LTC2400 from an LT1761 low noise regulator. Although this device has exceptionally low noise for a power regulator, it may still slightly elevate the noise floor of the LTC2400. For lowest noise operation, the LTC2400 may be powered from the onboard LT1236 reference by cutting the indicated trace and connecting V_{REF} to V_{CC} as shown in Figure 3.

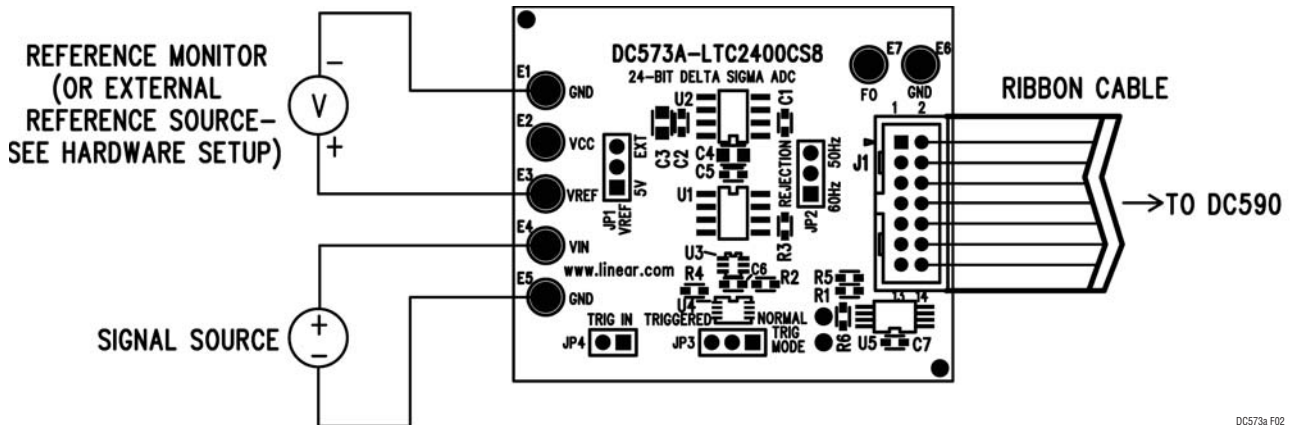

Figure 2. Proper Measurement Equipment Setup

DC573a F02

EXPERIMENTS

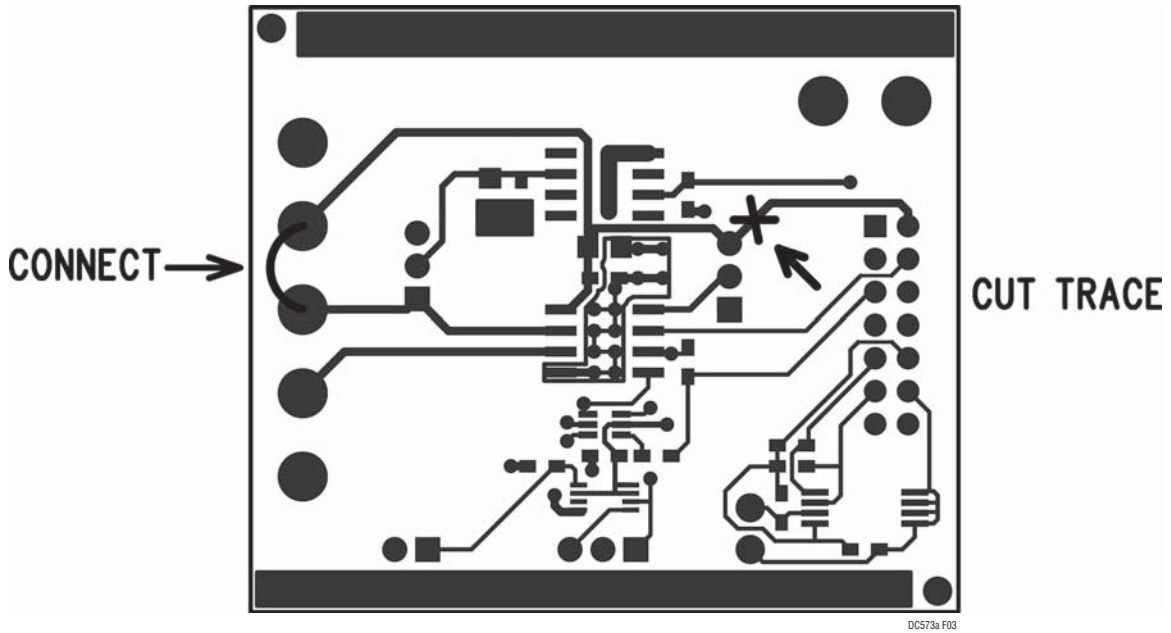

Figure 3. Low Noise Setup

DEMO MANUAL DC573A

PARTS LIST

ITEM	QTY	REFERENCE	PART DESCRIPTION	MANUFACTURER/PART NUMBER
1	4	C1, C2, C6, C7	CAP, X7R 0.1 μ F 16V, 0603	AVX, 0603YC104MAT1A
2	1	C3	CAP, X5R 4.7 μ F 6.3V, 20%, 0805	TAIYO YUDEN, JMK212BJ475MGT
3	1	C4	CAP, X5R, 10 μ F 6.3V, 20%, 0805	TDK, C2012X5R0J106M
4	1	C5	CAP, X7R 0.01 μ F 16V 10%, 0603	AVX, 0603YC103KAT1A
5	7	E1 TO E7	TESTPOINT, TURRET, 0.064"	MILL-MAX, 2308-2
6	3	JP1, JP2, JP3	JMP, 3PIN 1 ROW 0.079CC	COMM-CON, 2802S-03-G1
7	3	SHUNTS FOR JP1, JP2, JP3	SHUNT, 0.079" CENTER	COMM-CON CCIJ2MM-138G
8	0	JP4	JMP, HD1X2-079	OPT
9	1	J1	HEADER, 2 x 7PIN, 0.079CC	MOLEX, 87331-1420
10	3	R1, R5, R6	RES, CHIP 4.99k 1/16W 1%, 0603	AAC, CR16-4991FM
11	1	R2	RES, CHIP 100 1/16W 5%, 0603	AAC, CR16-101JM
12	0	R3	RES, 0603	OPT
13	1	R4	RES, CHIP 10k 1/16W 5%, 0603	AAC, CR16-103JM
14	1	U1	IC, LTC2400CS8, S08	LINEAR TECHNOLOGY, LTC2400CS8
15	1	U2	IC, LT1236ACS8-5, S08	LINEAR TECHNOLOGY, LT1236ACS8-5
16	1	U3	IC, NC7SZ157P6X, SC70-6P	FAIRCHILD SEMI, NC7SZ157P6X
17	1	U4	IC, NL17SZ74US, US8	ON SEMI, NL17SZ74US
18	1	U5	IC, 24LC025, TSSOP-8	MICROCHIP, 24LC025-I /ST

SCHEMATIC DIAGRAM

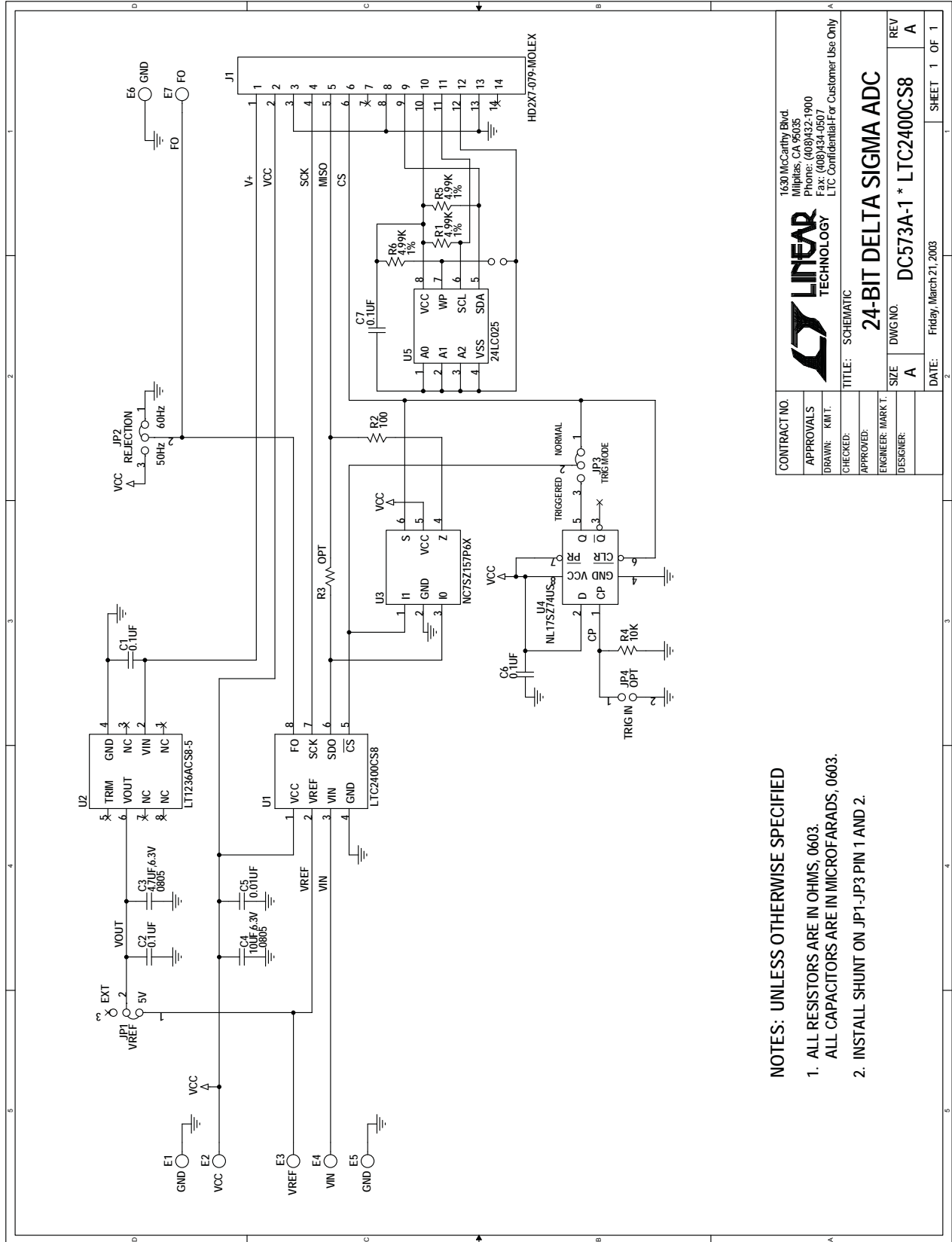

NOTES: UNLESS OTHERWISE SPECIFIED

1. ALL RESISTORS ARE IN OHMS, 0603.
2. ALL CAPACITORS ARE IN MICROFARADS, 0603.
3. INSTALL SHUNT ON JP1-JP3 PIN 1 AND 2.

CONTRACT NO.		1630 McCarthy Blvd.	
APPROVALS		Milpitas, CA 95035	
DRAWN: KMT		Phone: (408)432-1900	
CHECKED:		Fax: (408)434-0507	
APPROVED:		LTC Confidential-For Customer Use Only	
ENGINEER: MARK T.		TITLE: SCHEMATIC	
DESIGNER:		24-BIT DELTA SIGMA ADC	
SIZE	DWG NO.	REV	
A	DC573A-1 * LTC2400CS8	A	
DATE: Friday, March 21, 2003		SHEET 1 OF 1	

DEMO MANUAL DC573A

DEMONSTRATION BOARD IMPORTANT NOTICE

Linear Technology Corporation (LTC) provides the enclosed product(s) under the following **AS IS** conditions:

This demonstration board (DEMO BOARD) kit being sold or provided by Linear Technology is intended for use for **ENGINEERING DEVELOPMENT OR EVALUATION PURPOSES ONLY** and is not provided by LTC for commercial use. As such, the DEMO BOARD herein may not be complete in terms of required design-, marketing-, and/or manufacturing-related protective considerations, including but not limited to product safety measures typically found in finished commercial goods. As a prototype, this product does not fall within the scope of the European Union directive on electromagnetic compatibility and therefore may or may not meet the technical requirements of the directive, or other regulations.

If this evaluation kit does not meet the specifications recited in the DEMO BOARD manual the kit may be returned within 30 days from the date of delivery for a full refund. **THE FOREGOING WARRANTY IS THE EXCLUSIVE WARRANTY MADE BY THE SELLER TO BUYER AND IS IN LIEU OF ALL OTHER WARRANTIES, EXPRESSED, IMPLIED, OR STATUTORY, INCLUDING ANY WARRANTY OF MERCHANTABILITY OR FITNESS FOR ANY PARTICULAR PURPOSE. EXCEPT TO THE EXTENT OF THIS INDEMNITY, NEITHER PARTY SHALL BE LIABLE TO THE OTHER FOR ANY INDIRECT, SPECIAL, INCIDENTAL, OR CONSEQUENTIAL DAMAGES.**

The user assumes all responsibility and liability for proper and safe handling of the goods. Further, the user releases LTC from all claims arising from the handling or use of the goods. Due to the open construction of the product, it is the user's responsibility to take any and all appropriate precautions with regard to electrostatic discharge. Also be aware that the products herein may not be regulatory compliant or agency certified (FCC, UL, CE, etc.).

No License is granted under any patent right or other intellectual property whatsoever. **LTC assumes no liability for applications assistance, customer product design, software performance, or infringement of patents or any other intellectual property rights of any kind.**

LTC currently services a variety of customers for products around the world, and therefore this transaction **is not exclusive**.

Please read the DEMO BOARD manual prior to handling the product. Persons handling this product must have electronics training and observe good laboratory practice standards. **Common sense is encouraged.**

This notice contains important safety information about temperatures and voltages. For further safety concerns, please contact a LTC application engineer.

Mailing Address:

Linear Technology
1630 McCarthy Blvd.
Milpitas, CA 95035

Copyright © 2004, Linear Technology Corporation