



The Future of Analog IC Technology[®]

EVKT850-KNOB-Q-01A

Rotary Knob Kit for the MagAlpha

DESCRIPTION

The EVKT-KNOB is an evaluation kit for the MagAlpha magnetic position sensor family. The EVKT-KNOB allows users to run and test the MagAlpha sensor quickly. It is delivered assembled with a knob and magnet. The sensor is mounted in an end-of-shaft configuration.

The EVKT-KNOB is compatible with the MACOM kit, offering seamless connection and operation of the MagAlpha and allowing users to evaluate MagAlpha functionalities and performances, such as noise level, refresh rate, power-up time, magnetic field dependence, and so on.

FEATURES

- Ready-to-Use Knob with End-of-Shaft Magnet
- Extra Spacers
- Compatible with MagAlpha Communication Interface Kit (EVKT-MACOM)

APPLICATIONS

- Knobs
- Potentiometer Replacements
- Dials
- Appliances
- Consumer Goods

All MPS parts are lead-free, halogen-free, and adhere to the RoHS directive. For MPS green status, please visit the MPS website under Quality Assurance. "MPS" and "The Future of Analog IC Technology" are registered trademarks of Monolithic Power Systems, Inc.

OVERVIEW

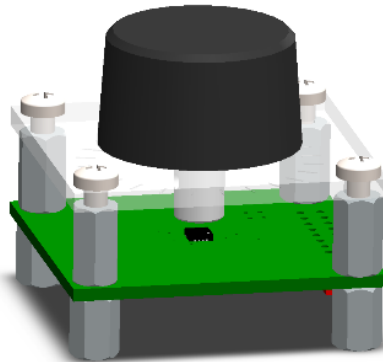

Figure 1: EVKT-KNOB

Board Type

Different board types are available, and each of them has a different schematic and layout design. The board type to use is determined by the selected sensor part number.

Table 1: Board Type

Board Type	Kit Part Number	Board Part Number	MPS Chip Part Number
Board type 1	EVKT100-KNOB	EVMA100-Q-00A	MA100
	EVKT300-KNOB	EVMA300-Q-00A	MA300
	EVKT700-KNOB	EVMA700-Q-00A	MA700
	EVKT750-KNOB	EVMA750-Q-00A	MA750
Board type 2	EVKT102-KNOB	EVMA102-Q-01A	MA102
	EVKT302-KNOB	EVMA302-Q-01A	MA302
	EVKT310-KNOB	EVMA310-Q-01A	MA310
	EVKT702-KNOB	EVMA702-Q-01A	MA702
	EVKT710-KNOB	EVMA710-Q-01A	MA710
	EVKT730-KNOB	EVMA730-Q-01A	MA730
	EVKT800-KNOB	EVMA800-Q-01A	MA800
	EVKT820-KNOB	EVMA820-Q-01A	MA820
EVKT850-KNOB	EVMA850-Q-01A	MA850	

EVKT-KNOB Content

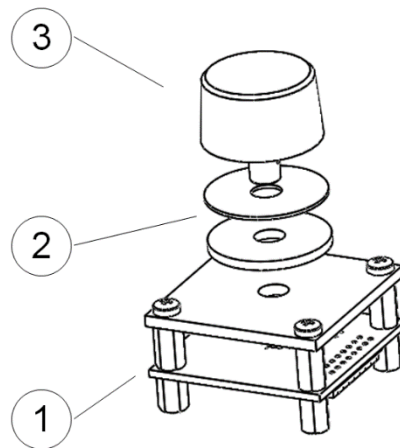

Figure 2: Kit Contents

1. EVMA board with MagAlpha mounted
2. 0.7mm and 2.0mm spacers
3. Knob with magnet
4. Extra cylinder magnet, NdFeB N35 D=5mm H=2.5mm (not shown)

BOARD TYPE 1

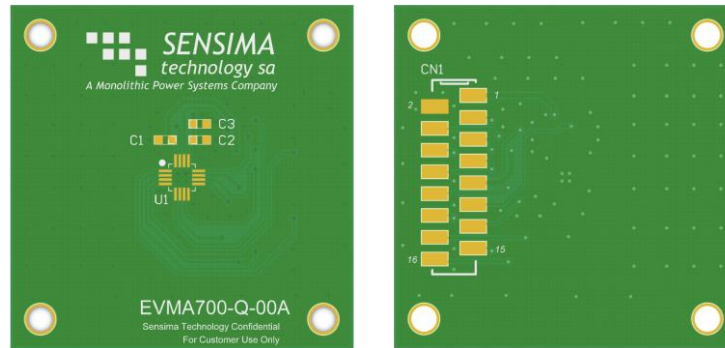

Figure 3: Board Overview Type 1

Schematic

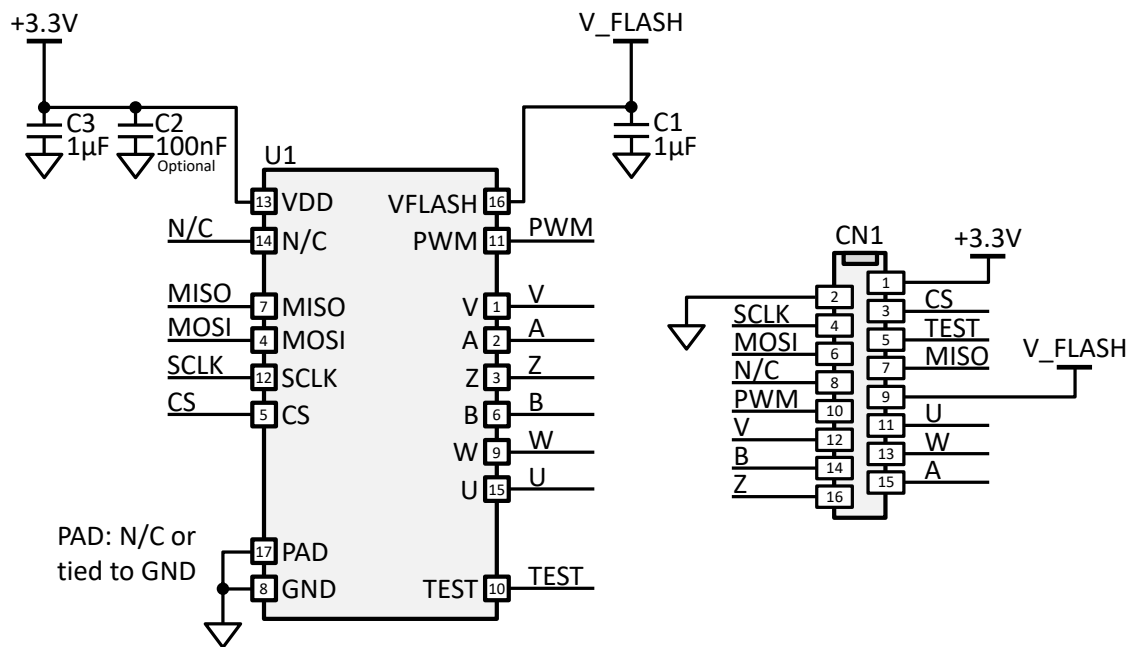

Figure 4: Schematic Type 1

Bill of Materials

Table 2: Bill of Materials Type 1

Quantity	Designator	Description	Value	Manufacturer	Manufacturer PN
2	C1, C3	Ceramic capacitor;16V;X7R;0603;	1µF	Murata	GRM188R71C105MA12D
1	C2 (optional)	Ceramic capacitor;25V;X7R;0603;	100nF	Murata	GRM188R71E104MA01D
1	U1	MagAlpha magnetic position sensor	MAxxx	MPS	
1	CN1	16 position receptacle connector 0.100" (2.54mm) surface mount tin		Würth Elektronik or TE Connectivity	690367281676 or 8-2178711-6

Assembly View

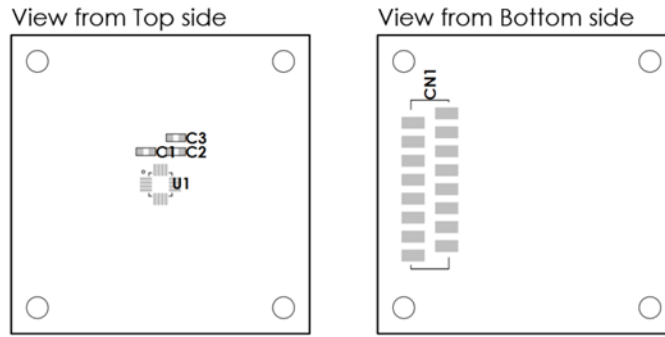

Figure 5: Assembly View Type 1

Mechanical Drawing

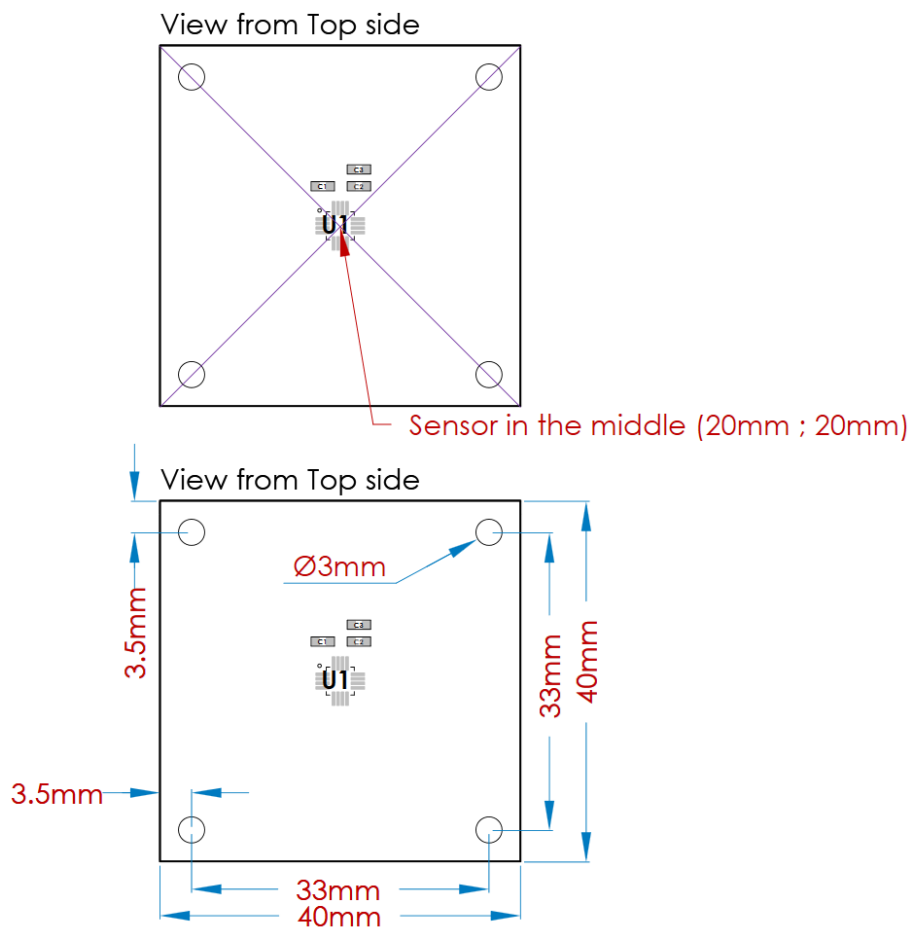
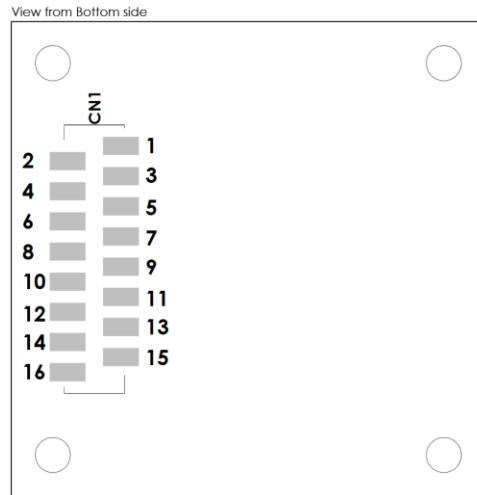

Figure 6: Mechanical Drawing Type 1

Connector Pin-Out

Figure 7: Connector Pin-Out Type 1
Table 3: Connector Pin Mapping Type 1

Pin	Name	Description
CN1.1	VDD	3.3V supply.
CN1.2	GND	Ground.
CN1.3	CS	Chip select (serial).
CN1.4	SCLK	Clock (serial).
CN1.5	TEST	Test pin.
CN1.6	MOSI	Master out slave in (serial).
CN1.7	MISO	Master in slave out (serial).
CN1.8	-	Leave unconnected.
CN1.9	V_FLASH	Flash power supply (3.9V only powered during flashing).
CN1.10	PWM ¹	Pulse width modulation output (option).
CN1.11	U ¹	U output (motor commutation option).
CN1.12	V ¹	V output (motor commutation option).
CN1.13	W ¹	W output (motor commutation option).
CN1.14	A ¹	A output (incremental encoder option).
CN1.15	B ¹	B output (incremental encoder option).
CN1.16	Z ¹	Z output (incremental encoder option).

NOTE:

- 1) The availability of this option depends of the chip part ID. Please refer to the part datasheet directly.

BOARD TYPE 2

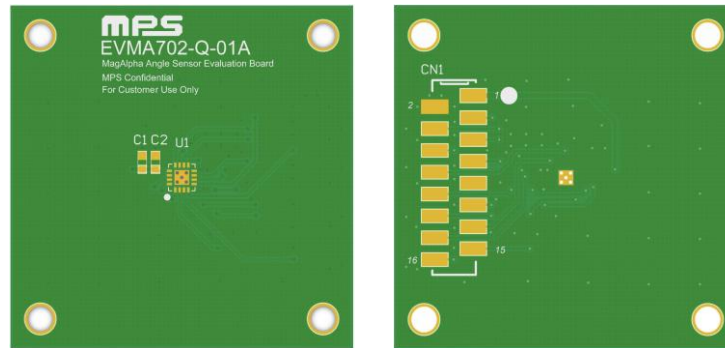

Figure 8: Board Overview Type 2

Schematic

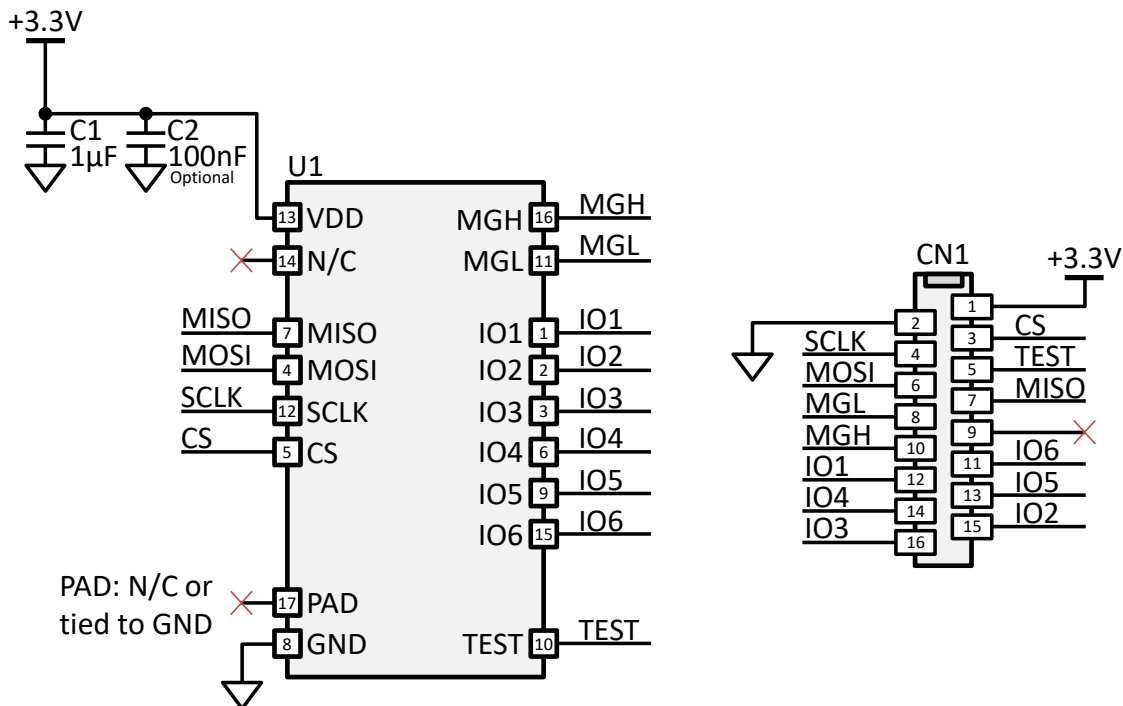

Figure 9: Schematic Type 2

Bill of Materials

Table 4: Bill of Materials Type 2

Quantity	Designator	Description	Value	Manufacturer	Manufacturer PN
1	C1	Ceramic capacitor; 16V; X7R; 0603;	1µF	Murata	GRM188R71C105MA12D
1	C2 (not populated)	Ceramic capacitor; 25V; X7R; 0603;	100nF	Murata	GRM188R71E104MA01D
1	U1	MagAlpha magnetic position sensor	MAxxx	MPS	
1	CN1	16 position receptacle connector 0.100" (2.54mm) surface mount tin		Würth Elektronik or TE Connectivity	690367281676 or 8-2178711-6

Assembly View

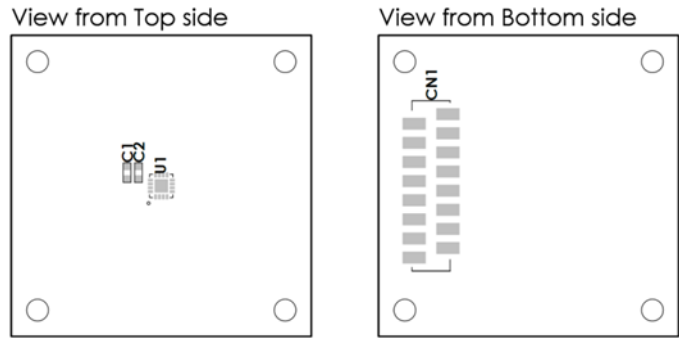

Figure 10: Assembly View Type 2

Mechanical Drawing

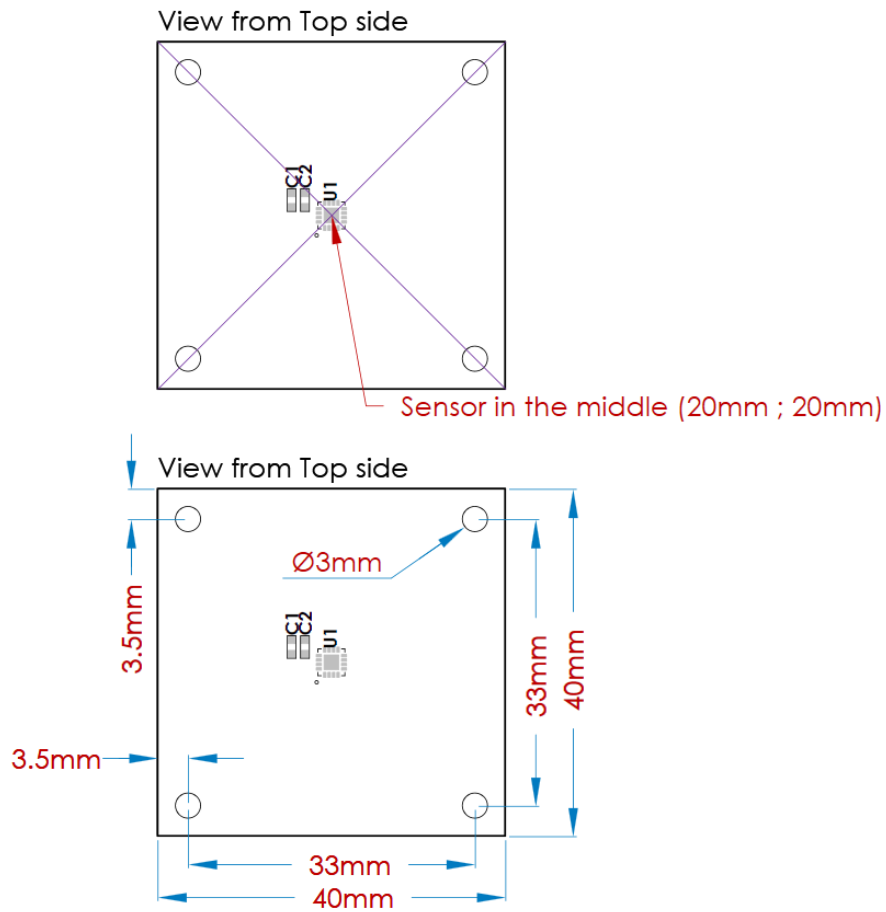
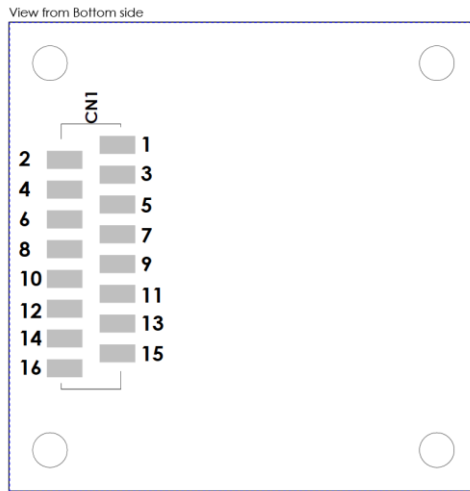

Figure 11: Mechanical Drawing Type 2

Connector Pin-Out

Figure 12: Connector Pin-Out Type 2
Table 5: Connector Pin Mapping Type 2

Pin	Name	Description
CN1.1	VDD	3.3V supply.
CN1.2	GND	Ground.
CN1.3	CS	Chip select (serial).
CN1.4	SCLK	Clock (serial).
CN1.5	TEST	Test pin.
CN1.6	MOSI	Master out slave in (serial).
CN1.7	MISO	Master in slave out (serial).
CN1.8	MGL ²	Magnetic level low (option).
CN1.9	-	-
CN1.10	MGH ²	Magnetic level high (option).
CN1.11	IO6 ³	Pin 15 (IO).
CN1.12	IO1 ³	Pin 1 (IO).
CN1.13	IO5 ³	Pin 9 (IO).
CN1.14	IO4 ³	Pin 6 (IO).
CN1.15	IO2 ³	Pin 2 (IO).
CN1.16	IO3 ³	Pin 3 (IO).

NOTES:

- 2) The availability of this option depends of the chip part ID. Please refer to the part datasheet directly.
- 3) Please refer to the chip datasheet directly to know which feature is available on this pin.

MAGNETIC FIELD

A NdFeB cylinder magnet is mounted at the end of the aluminum shaft.

Table 6: Magnet Characteristics

Material	NdFeB (N35 or N35H)
Remanence (Br)	1.2T
Diameter	5mm
Height	2.5mm
Magnetization	Diametrical

How to Change the Mechanical Zero

Unscrew the knob with a Hex key 1/16". Hold the shaft with a pin inserted in the 2mm diameter hole and rotate the knob to the desired position. When tightening the screw, ensure that the shaft is fully inserted. Note that the zero position can also be adjusted through programming, as described in the MagAlpha datasheet.

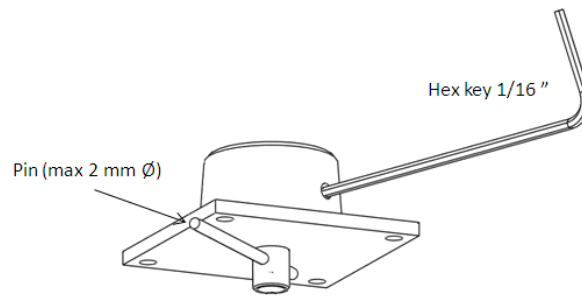

Figure 13: Adjusting the Magnet Angular Position

How to Change the Magnetic Field Amplitude

The performance of the MagAlpha remains the same from 75mT to 150mT and higher (the MagAlpha has no maximum operating field). The critical region is the lower end of the specified range. Some parameters (i.e.: noise, linearity) deteriorate gradually when the magnetic field becomes weak. The two spacers enclosed in this evaluation kit allow the sensor (the noise level in particular) to be tested at low magnetic fields.

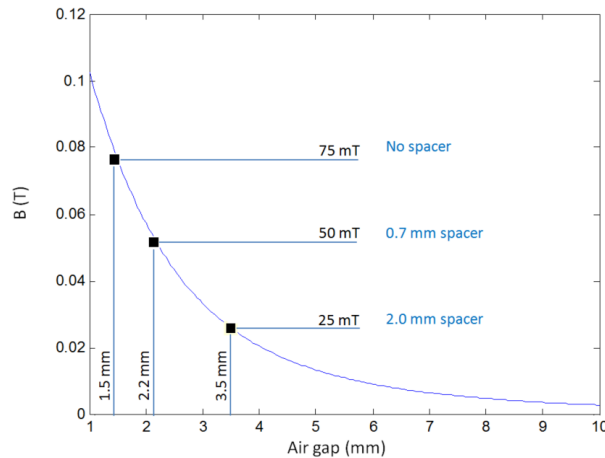
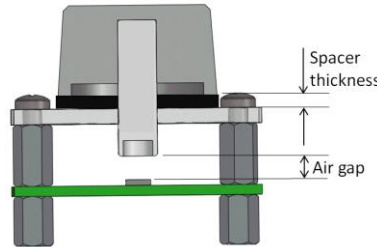

Figure 14: Magnetic Field vs. Air Gap for the Supplied Magnet

The EVMA nominal magnet sensor distance is 1.5mm, providing a magnetic field of 75mT. With the spacers, the field strength is reduced to 50mT or 25mT (see Table 7).

Table 7: Setting of the Air Gap

Spacer Thickness (mm)	Air Gap (mm)	Magnetic Field (mT)
None	1.5	75
0.7	2.2	50
2	3.5	25

Figure 15: Air Gap Setting

MAGNET SUPPLIERS

The table below shows a non-exhaustive list of possible magnet suppliers. The magnetization direction must be chosen wisely given the fact that most magnets sold are often axially magnetized, which is not a magnetization direction usually required in magnetic angle sensing applications. Angle sensing applications usually use diametrically magnetized magnets.

Table 8: Magnet Suppliers

Company	Website	Address
Maurer Magnetics AG	www.maurermagnetic.ch	Industriestrasse 8 8627 Grüningen Switzerland
Arnold Technologies AG	www.arnoldmagnetics.com	Hübelacherstrasse 15 5242 Birr-Lupfig Switzerland
Bomatec AG	www.bomatec.com	Hofstrasse 1 8181 Höri Switzerland
Dexter Magnetic Technologies	www.dextermag.com	1050 Morse Avenue Elk Grove Village, IL 60007-5110 USA
JPMF	www.jpmp.com.cn	8 LongWan Road Jiangmen City GuangDong Province China
Binicmagnet	www.binicmagnet.com	Unit 612 Yuanzhong Building No. 1905 Hongmei Road Shanghai P. R. China 200233
China Rare Earth Magnet	www.permanentmagnet.com	Room 705, Tower A Century Holiday Plaza 9030 Shennan Rd Nanshan District Shenzhen China
Goudsmit Magnetic Systems	www.goudsmit-magnetics.nl	Petunialaan 19 5582 HA Waalre Netherlands

Maurer Magnetic

Maurer Magnetic has a selection of diametrically magnetized magnets well-suited for contactless rotary angle applications. Samples of the types mentioned below should always be available with no lead time.

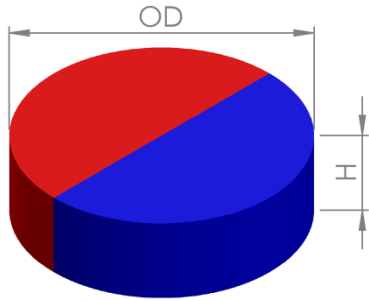

Figure 16: Cylinder Magnet, Diametrically Magnetized

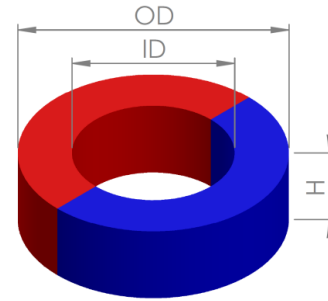

Figure 17: Ring Magnet, Diametrically Magnetized

Table 9: Maurer Magnetic Diametrically Magnetized Magnets

OD (mm)	ID (mm)	H (mm)	Material	Remanence (Br) (T)	Magnetization	Part Number
4.0	-	3.0	N35	1.2	Diametrical	M610403
4.0	-	3.0	Sm26/16-17	1.08	Diametrical	M410403
5.0	-	2.5	N35	1.2	Diametrical	M610502
5.0	-	2.5	Sm26/16-17	1.08	Diametrical	M410502
5.0	1.25	2.5	N35	1.2	Diametrical	M610512
5.0	1.25	2.5	Sm26/16-17	1.08	Diametrical	M410512
6.0	-	2.5	N35	1.2	Diametrical	M610602
6.0	-	2.5	Sm26/16-17	1.08	Diametrical	M410602
6.0	1.5	2.5	N35	1.2	Diametrical	M610612
6.0	1.5	2.5	Sm26/16-17	1.08	Diametrical	M410612
6.0	1.5	3.0	N35	1.2	Diametrical	M610613
6.0	1.5	3.0	Sm26/16-17	1.08	Diametrical	M410613
8.0	-	2.5	N35	1.2	Diametrical	M610802
8.0	-	2.5	Sm26/16-17	1.08	Diametrical	M410802

NOTICE: The information in this document is subject to change without notice. Users should warrant and guarantee that third party Intellectual Property rights are not infringed upon when integrating MPS products into any application. MPS will not assume any legal responsibility for any said applications.