

High temperature accelerometer

376

SPECIFICATIONS

Sensitivity, 25°C, nominal		25 pC/g
Amplitude nonlinearity, to 250 g		1%
Frequency response:	±5%	6,000 Hz
	±10%	8,000 Hz
	±3 dB	12,000 Hz
Resonance frequency		30 kHz
Transverse sensitivity, max		7% of axial
Temperature response:	-50°C	+10%
	+260°C	+20%
Capacitance		500 pF
Resistance, min		1,000 MΩ
Grounding		case isolated
Temperature range		-50° to +260°C
Vibration limit		500 g peak
Shock limit, max		5,000 g peak
Sealing		welded
Base strain sensitivity, max		0.002 g/μstrain
Humidity limit		100% relative
Sensing element design		PZT ceramic / compression
Weight		75 grams
Case material		stainless steel
Mounting		1/4-28 tapped hole
Output connector		10-32 coaxial
Mating connector		R1
Recommended cabling		J3

Accessories supplied: SF6 mounting stud (international customers specify mounting requirements); calibration data (level 3)



Key features

- Industrial ruggedness
- Charge output
- 260°C operation
- Manufactured in ISO 9001 facility

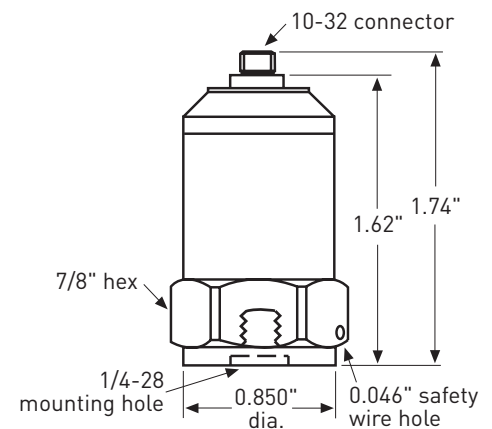

Connections	
Function	Connector pin
crystal, positive	shell
crystal, negative	pin



Note: Due to continuous process improvement, specifications are subject to change without notice. This document is cleared for public release.