

# MICRO SWITCH

FREERPORT ILLINOIS, U S A  
A DIVISION OF HONEYWELL  
FED. MFG. CODE 91929

# ASSEMBLY- PUSHBUTTON SWITCH

CATALOG LISTING  
**IPB587**

REPLACES

**IPB587**

**M**

DRAWING  
NUMBER

ISSUE

RELEASE NO. PR-15634

CHECK

REVISIONS

CHECK

CHECK

CHECK

CHECK

CHECK

CHECK

CHECK

CHECK

CHECK

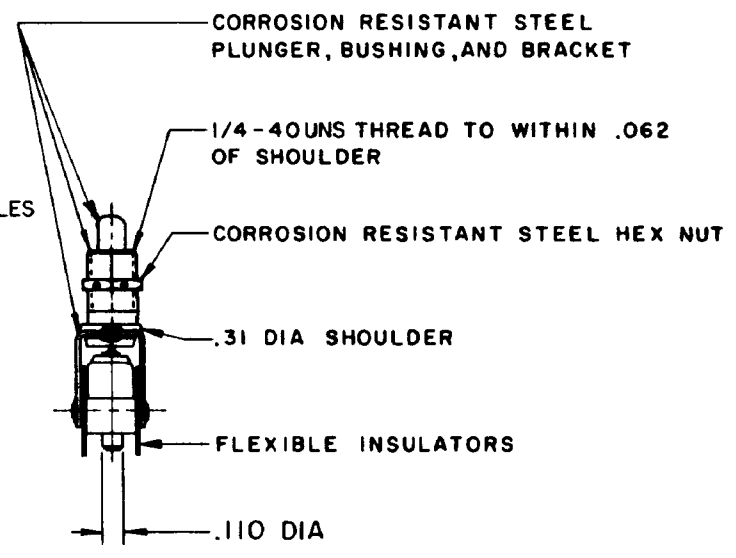
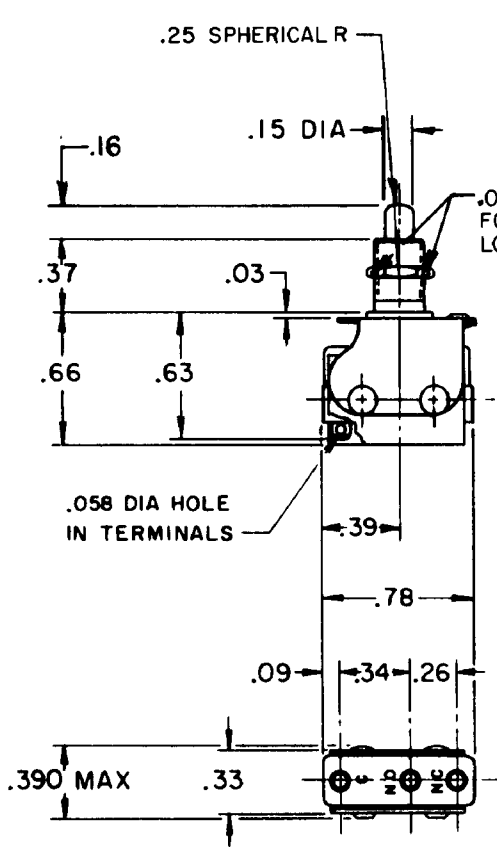

- NOTE -
- 1 - UNIT INCLUDES "12SM83" TYPE BASIC SWITCH
  - 2 - TERMINALS ARE PLATED FOR SOLDERING
  - 3 - RECOMMENDED FOR MANUAL OPERATION ONLY

THIS DRAWING COVERS A PROPRIETARY ITEM AND IS THE PROPERTY OF MICRO SWITCH, A DIVISION OF HONEYWELL. THIS DRAWING IS NOT TO BE COPIED OR USED WITHOUT THE APPROVAL OF MICRO SWITCH.

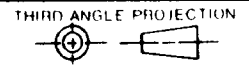

CHARACTERISTICS	
OPERATING FORCE	----- 2 LBS MAX
OVERTRAVEL FORCE	----- 2.5 LBS MAX
RELEASE FORCE	----- 2 OZ MIN
DIFFERENTIAL TRAVEL	----- .031 MAX
OVERTRAVEL	----- .100 MIN

ELECTRICAL DATA	
CONTACT ARRANGEMENT S P D T	
30 VOLTS DC RATING	
INDUCTIVE	----- SEA LEVEL - 1/2 AMP
	50,000 FT - 1/2 AMP
RESISTIVE	----- SEA LEVEL - 1 AMP
	50,000 FT - 1 AMP
MAXIMUM INRUSH	----- 2 AMP

SCALE FULL	
DO NOT SCALE PRINT	
TOLERANCES	
APPLY TO DESIGN UNITS CONVERSIONS ARE ONLY FOR REFERENCE UNLESS NOTED TOLERANCES ARE ±	
DIM	TOL
mm	mm/in
in	in
NO PLACES	X
ONE PLACE	X, X
TWO PLACES	X, XX
THREE PLACES	X, XXX
ANGLES	
SI METRIC	US CUSTOMARY
DESIGN UNITS	<input type="checkbox"/> <input checked="" type="checkbox"/>
WEIGHT	

FO-52848-A

DRAWN

JAS 121 MAY 87

CHECK