

## Quad channel high-side driver with CurrentSense analog feedback for automotive applications

Datasheet - production data



### Features

Max transient supply voltage	$V_{CC}$	40 V
Operating voltage range	$V_{CC}$	4 to 28 V
Typ. on-state resistance (per Ch)	$R_{ON}$	50 m $\Omega$
Current limitation (typ)	$I_{LIMH}$	27 A
Stand-by current (max)	$I_{STBY}$	0.5 $\mu$ A

- Automotive qualified
- General
  - Quad channel smart high-side driver with CS analog feedback
  - Very low standby current
  - Compatible with 3 V and 5 V CMOS outputs
- CurrentSense diagnostic functions
  - Analog feedback of load current with high precision proportional current mirror
  - Overload and short to ground (power limitation) indication
  - Thermal shutdown indication
  - OFF-state open-load detection
  - Output short to  $V_{CC}$  detection
  - Sense enable/disable
- Protections
  - Undervoltage shutdown
  - Overvoltage clamp
  - Load current limitation

- Self limiting of fast thermal transients
- Configurable latch-off on overtemperature or power limitation with dedicated fault reset pin
- Loss of ground and loss of  $V_{CC}$
- Reverse battery with external components
- Electrostatic discharge protection

### Applications

- All types of Automotive resistive, inductive and capacitive loads
- Specially intended for Automotive Signal Lamps (up to P27W or SAE1156 or LED Rear Combinations)

### Description

The device is a quad channel high-side driver manufactured using ST proprietary VIPower<sup>®</sup> M0-7 technology and housed in PowerSSO-16 package. The device is designed to drive 12 V automotive grounded loads through a 3 V and 5 V CMOS-compatible interface, providing protection and diagnostics.

The device integrates advanced protective functions such as load current limitation, overload active management by power limitation and overtemperature shutdown with configurable latch-off.

A  $\overline{\text{FaultRST}}$  pin unlatches the output in case of fault or disables the latch-off functionality.

A sense enable pin allows OFF-state diagnosis to be disabled during the module low-power mode as well as external sense resistor sharing among similar devices.

---

**Contents**

<b>1</b>	<b>Block diagram and pin description .....</b>	<b>5</b>
<b>2</b>	<b>Electrical specification.....</b>	<b>7</b>
2.1	Absolute maximum ratings .....	7
2.2	Thermal data .....	8
2.3	Main electrical characteristics .....	8
2.4	Waveforms .....	16
2.5	Electrical characteristics curves .....	19
<b>3</b>	<b>Protections.....</b>	<b>23</b>
3.1	Power limitation.....	23
3.2	Thermal shutdown.....	23
3.3	Current limitation .....	23
3.4	Negative voltage clamp .....	23
<b>4</b>	<b>Application information .....</b>	<b>24</b>
4.1	GND protection network against reverse battery.....	24
4.1.1	Diode (DGND) in the ground line .....	25
4.2	Immunity against transient electrical disturbances .....	25
4.3	MCU I/Os protection.....	25
4.4	CS - analog current sense .....	26
4.4.1	Principle of CurrentSense signal generation .....	27
4.4.2	Short to VCC and OFF-state open-load detection .....	29
<b>5</b>	<b>Maximum demagnetization energy (VCC = 16 V) .....</b>	<b>31</b>
<b>6</b>	<b>Package and PCB thermal data .....</b>	<b>32</b>
6.1	PowerSSO-16 thermal data .....	32
<b>7</b>	<b>Package information .....</b>	<b>35</b>
7.1	PowerSSO-16 package information .....	35
7.2	PowerSSO-16 packing information .....	37
7.3	PowerSSO-16 marking information.....	39
<b>8</b>	<b>Order codes .....</b>	<b>40</b>
<b>9</b>	<b>Revision history .....</b>	<b>41</b>

## List of tables

Table 1: Pin functions .....	5
Table 2: Suggested connections for unused and not connected pins.....	6
Table 3: Absolute maximum ratings .....	7
Table 4: Thermal data.....	8
Table 5: Power section .....	8
Table 6: Switching ( $V_{CC} = 13\text{ V}$ ; $-40^{\circ}\text{C} < T_j < 150^{\circ}\text{C}$ , unless otherwise specified) .....	9
Table 7: Logic Inputs ( $7\text{ V} < V_{CC} < 28\text{ V}$ ; $-40^{\circ}\text{C} < T_j < 150^{\circ}\text{C}$ ).....	10
Table 8: Protections ( $7\text{ V} < V_{CC} < 18\text{ V}$ ; $-40^{\circ}\text{C} < T_j < 150^{\circ}\text{C}$ ) .....	10
Table 9: CurrentSense ( $7\text{ V} < V_{CC} < 18\text{ V}$ ; $-40^{\circ}\text{C} < T_j < 150^{\circ}\text{C}$ ).....	11
Table 10: Truth table.....	15
Table 11: Current sense multiplexer addressing .....	16
Table 12: ISO 7637-2 - electrical transient conduction along supply line.....	25
Table 13: CurrentSense pin levels in off-state.....	29
Table 14: PCB properties .....	32
Table 15: Thermal parameters .....	34
Table 16: PowerSSO-16 mechanical data.....	35
Table 17: Reel dimensions .....	37
Table 18: PowerSSO-16 carrier tape dimensions .....	38
Table 19: Device summary .....	40
Table 20: Document revision history .....	41

## List of figures

Figure 1: Block diagram .....	5
Figure 2: Configuration diagram (top view).....	6
Figure 3: Current and voltage conventions.....	7
Figure 4: Switching times and Pulse skew .....	14
Figure 5: Current sense timings (current sense mode) .....	14
Figure 6: TDSKON.....	15
Figure 7: Latch functionality - behavior in hard short circuit condition (TAMB << TTSD) .....	16
Figure 8: Latch functionality - behavior in hard short circuit condition.....	17
Figure 9: Latch functionality - behavior in hard short circuit condition (autorestart mode + latch off) .....	17
Figure 10: Standby mode activation .....	18
Figure 11: Standby state diagram.....	18
Figure 12: OFF-state output current .....	19
Figure 13: Standby current .....	19
Figure 14: IGND(ON) vs Tcase .....	19
Figure 15: Logic Input high level voltage .....	19
Figure 16: Logic Input low level voltage.....	19
Figure 17: High level logic input current .....	19
Figure 18: Low level logic input current .....	20
Figure 19: Logic Input hysteresis voltage .....	20
Figure 20: FaultRST Input clamp voltage .....	20
Figure 21: Undervoltage shutdown.....	20
Figure 22: On-state resistance vs Tcase.....	20
Figure 23: On-state resistance vs VCC .....	20
Figure 24: Turn-on voltage slope.....	21
Figure 25: Turn-off voltage slope.....	21
Figure 26: Won vs Tcase.....	21
Figure 27: Woff vs Tcase.....	21
Figure 28: ILIMH vs. Tcase.....	21
Figure 29: OFF-state open-load voltage detection threshold .....	21
Figure 30: Vsense clamp vs. Tcase.....	22
Figure 31: Vsenseh vs. Tcase .....	22
Figure 32: Application diagram .....	24
Figure 33: Simplified internal structure .....	24
Figure 34: CurrentSense and diagnostic – block diagram.....	26
Figure 35: CurrentSense block diagram.....	27
Figure 36: Analogue HSD – open-load detection in off-state .....	28
Figure 37: Open-load / short to VCC condition.....	29
Figure 38: Maximum turn off current versus inductance .....	31
Figure 39: PowerSSO-16 on two-layers PCB (2s0p to JEDEC JESD 51-5) .....	32
Figure 40: PowerSSO-16 on four-layers PCB (2s2p to JEDEC JESD 51-7) .....	32
Figure 41: Rthj-amb vs PCB copper area in open box free air condition (one channel on) .....	33
Figure 42: PowerSSO-16 thermal impedance junction ambient single pulse (one channel on) .....	33
Figure 43: Thermal fitting model of a double-channel HSD in PowerSSO-16.....	34
Figure 44: PowerSSO-16 package dimensions.....	35
Figure 45: PowerSSO-16 reel 13" .....	37
Figure 46: PowerSSO-16 carrier tape .....	38
Figure 47: PowerSSO-16 schematic drawing of leader and trailer tape .....	38
Figure 48: PowerSSO-16 marking information.....	39

# 1 Block diagram and pin description

Figure 1: Block diagram

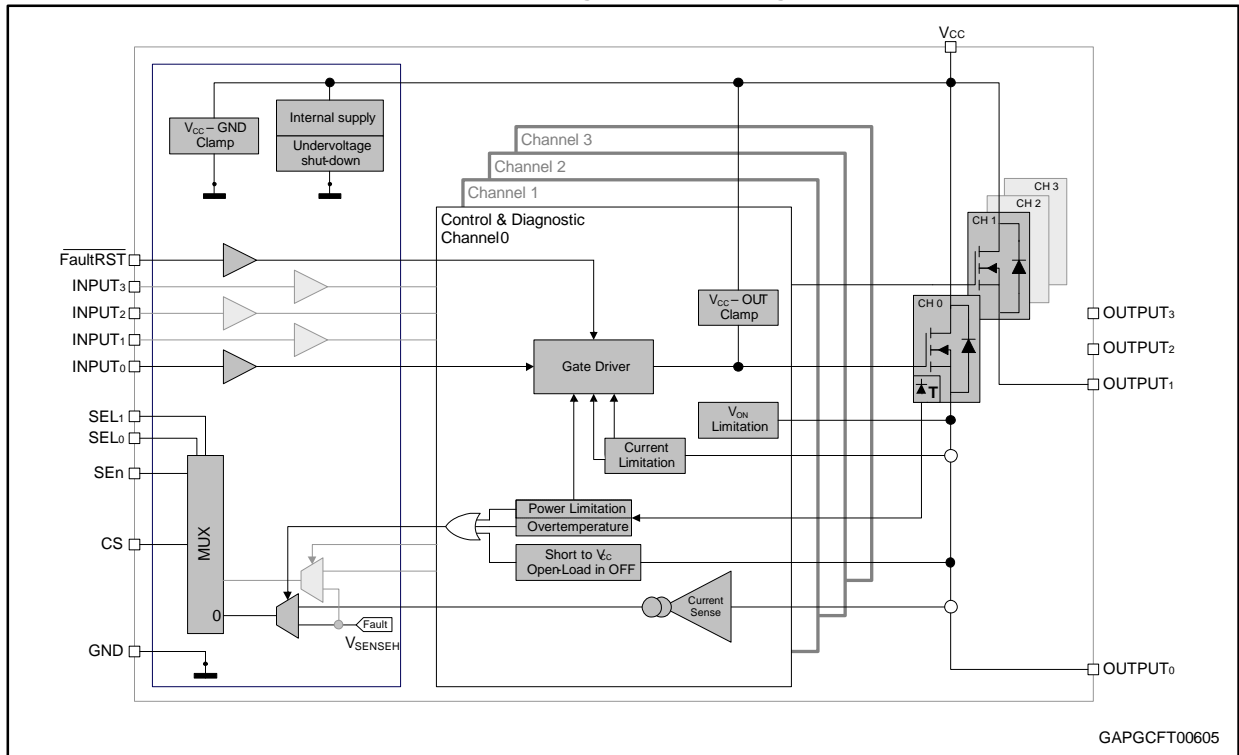


Table 1: Pin functions

Name	Function
V <sub>CC</sub>	Battery connection.
OUTPUT <sub>0,1,2,3</sub>	Power output.
GND	Ground connection. Must be reverse battery protected by an external diode / resistor network.
INPUT <sub>0,1,2,3</sub>	Voltage controlled input pin with hysteresis, compatible with 3 V and 5 V CMOS outputs. They control output switch state.
CS	Analog current sense output pin delivers a current proportional to the load current.
SEn	Active high, compatible with 3 V and 5 V CMOS outputs input pin; it enables the CS diagnostic pin.
SEL <sub>0,1</sub>	Active high, compatible with 3 V and 5 V CMOS outputs input pin; They address the CS multiplexer.
FaultRST	Active low, compatible with 3 V and 5 V CMOS outputs input pin; it unlatches the output in case of fault; If kept low, sets the outputs in auto-restart mode.

Figure 2: Configuration diagram (top view)

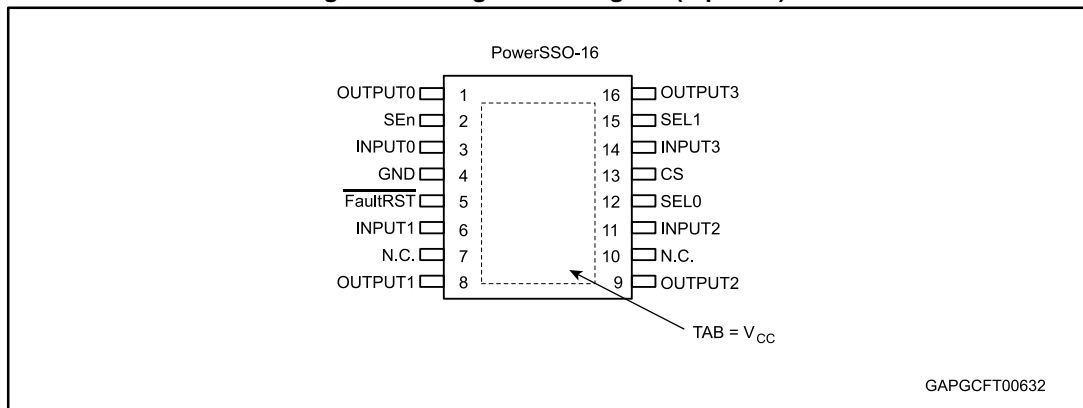


Table 2: Suggested connections for unused and not connected pins

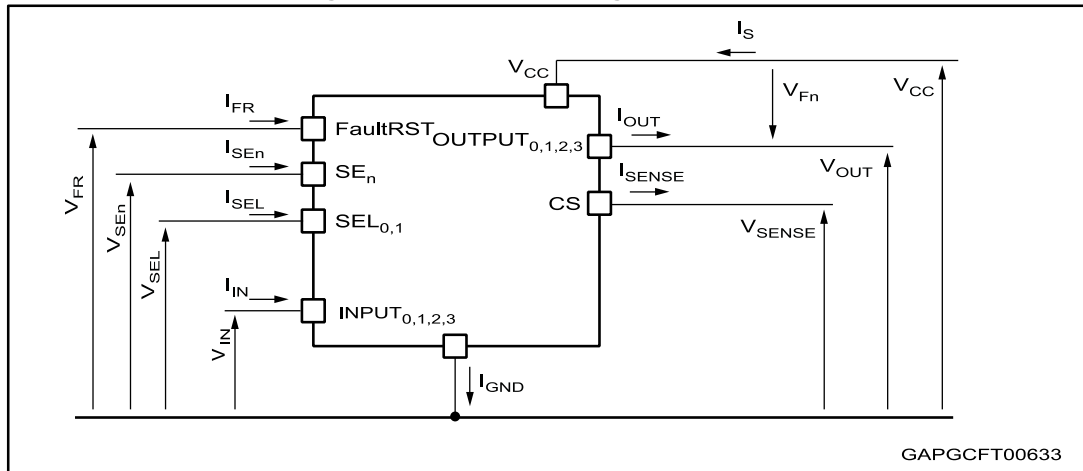
Connection / pin	CS	N.C.	Output	Input	SEn, SELx, FaultRST
Floating	Not allowed	X <sup>(1)</sup>	X	X	X
To ground	Through 1 kΩ resistor	X	Not allowed	Through 15 kΩ resistor	Through 15 kΩ resistor

**Notes:**

<sup>(1)</sup>X: do not care.

## 2 Electrical specification

Figure 3: Current and voltage conventions



$V_{Fn} = V_{OUTn} - V_{CC}$  during reverse battery condition.

### 2.1 Absolute maximum ratings

Stressing the device above the rating listed in [Table 3: "Absolute maximum ratings"](#) may cause permanent damage to the device. These are stress ratings only and operation of the device at these or any other conditions above those indicated in the operating sections of this specification is not implied. Exposure to the conditions in table below for extended periods may affect device reliability.

Table 3: Absolute maximum ratings

Symbol	Parameter	Value	Unit
$V_{CC}$	DC supply voltage	38	V
$-V_{CC}$	Reverse DC supply voltage	0.3	
$V_{CCPK}$	Maximum transient supply voltage (ISO 16750-2:2010 Test B clamped to 40 V; $R_L = 4 \Omega$ )	40	V
$V_{CCJS}$	Maximum jump start voltage for single pulse short circuit protection	28	V
$-I_{GND}$	DC reverse ground pin current	200	mA
$I_{OUT}$	OUTPUT <sub>0,1,2,3</sub> DC output current	Internally limited	A
$-I_{OUT}$	Reverse DC output current	16	
$I_{IN}$	INPUT <sub>0,1,2,3</sub> DC input current	-1 to 10	mA
$I_{SEn}$	SE <sub>n</sub> DC input current		
$I_{SEL}$	SEL <sub>0,1</sub> DC input current		
$I_{FR}$	FaultRST DC input current		
$V_{FR}$	FaultRST DC input voltage	7.5	V

Symbol	Parameter	Value	Unit
I <sub>SENSE</sub>	CS pin DC output current (V <sub>GND</sub> = V <sub>CC</sub> and V <sub>SENSE</sub> < 0 V)	10	mA
	CS pin DC output current in reverse (V <sub>CC</sub> < 0 V)	-20	
E <sub>MAX</sub>	Maximum switching energy (single pulse) (T <sub>DEMAG</sub> = 0.4 ms; T <sub>jstart</sub> = 150°C)	30	mJ
V <sub>ESD</sub>	Electrostatic discharge (JEDEC 22A-114F)		
	• INPUT <sub>0,1,2,3</sub>	4000	V
	• CS	2000	V
	• SEn, SEL <sub>0,1</sub> , FaultRST	4000	V
	• OUTPUT <sub>0,1,2,3</sub>	4000	V
• V <sub>CC</sub>	4000	V	
V <sub>ESD</sub>	Charge device model (CDM-AEC-Q100-011)	750	V
T <sub>j</sub>	Junction operating temperature	-40 to 150	°C
T <sub>stg</sub>	Storage temperature	-55 to 150	

## 2.2 Thermal data

Table 4: Thermal data

Symbol	Parameter	Typ. value	Unit
R <sub>thj-board</sub>	Thermal resistance junction-board (JEDEC JESD 51-5 / 51-8) <sup>(1)(2)</sup>	6.3	°C/W
R <sub>thj-amb</sub>	Thermal resistance junction-ambient (JEDEC JESD 51-5) <sup>(1)(3)</sup>	57.3	
R <sub>thj-amb</sub>	Thermal resistance junction-ambient (JEDEC JESD 51-7) <sup>(1)(2)</sup>	23.5	

**Notes:**

- (1)One channel ON.
- (2)Device mounted on four-layers 2s2p PCB.
- (3)Device mounted on two-layers 2s0p PCB with 2 cm<sup>2</sup> heatsink copper trace.

## 2.3 Main electrical characteristics

7 V < V<sub>CC</sub> < 28 V; -40°C < T<sub>j</sub> < 150°C, unless otherwise specified.

All typical values refer to V<sub>CC</sub> = 13 V; T<sub>j</sub> = 25°C, unless otherwise specified.

Table 5: Power section

Symbol	Parameter	Test conditions	Min.	Typ.	Max.	Unit
V <sub>CC</sub>	Operating supply voltage		4	13	28	V
V <sub>USD</sub>	Undervoltage shutdown				4	
V <sub>USDReset</sub>	Undervoltage shutdown reset				5	
V <sub>USDhyst</sub>	Undervoltage shutdown hysteresis			0.3		
R <sub>ON</sub>	On-state resistance <sup>(1)</sup>	I <sub>OUT</sub> = 2 A; T <sub>j</sub> = 25°C		50		mΩ
		I <sub>OUT</sub> = 2 A; T <sub>j</sub> = 150°C			100	
		I <sub>OUT</sub> = 2 A; V <sub>CC</sub> = 4 V; T <sub>j</sub> = 25°C			75	



Symbol	Parameter	Test conditions	Min.	Typ.	Max.	Unit
V <sub>clamp</sub>	Clamp voltage	I <sub>S</sub> = 20 mA; T <sub>j</sub> = -40°C	38			V
		I <sub>S</sub> = 20 mA; 25°C < T <sub>j</sub> < 150°C	41	46	52	
I <sub>STBY</sub>	Supply current in Standby at V <sub>CC</sub> = 13 V <sup>(2)</sup>	V <sub>CC</sub> = 13 V; V <sub>IN</sub> = V <sub>OUT</sub> = V <sub>FR</sub> = V <sub>SEn</sub> = 0 V; V <sub>SEL0,1</sub> = 0 V; T <sub>j</sub> = 25°C			0.5	μA
		V <sub>CC</sub> = 13 V; V <sub>IN</sub> = V <sub>OUT</sub> = V <sub>FR</sub> = V <sub>SEn</sub> = 0 V; V <sub>SEL0,1</sub> = 0 V; T <sub>j</sub> = 85°C <sup>(3)</sup>			0.5	μA
		V <sub>CC</sub> = 13 V; V <sub>IN</sub> = V <sub>OUT</sub> = V <sub>FR</sub> = V <sub>SEn</sub> = 0 V; V <sub>SEL0,1</sub> = 0 V; T <sub>j</sub> = 125°C			3	μA
t <sub>D_STBY</sub>	Standby mode blanking time	V <sub>CC</sub> = 13 V V <sub>IN</sub> = V <sub>OUT</sub> = V <sub>FR</sub> = V <sub>SEL0,1</sub> = 0 V; V <sub>SEn</sub> = 5 V to 0 V	60	300	550	μs
I <sub>S(ON)</sub>	Supply current	V <sub>CC</sub> = 13 V; V <sub>SEn</sub> = V <sub>FR</sub> = V <sub>SEL0,1</sub> = 0 V; V <sub>IN0,1,2,3</sub> = 5 V; I <sub>OUT0,1,2,3</sub> = 0 A		10	16	mA
I <sub>GND(ON)</sub>	Control stage current consumption in ON state. All channels active.	V <sub>CC</sub> = 13 V; V <sub>SEn</sub> = 5 V; V <sub>FR</sub> = V <sub>SEL0,1</sub> = 0 V; V <sub>IN0,1,2,3</sub> = 5 V; I <sub>OUT0,1,2,3</sub> = 1 A			20	mA
I <sub>L(off)</sub>	Off-state output current at V <sub>CC</sub> = 13 V <sup>(1)</sup>	V <sub>IN</sub> = V <sub>OUT</sub> = 0 V; V <sub>CC</sub> = 13 V; T <sub>j</sub> = 25°C	0	0.01	0.5	μA
		V <sub>IN</sub> = V <sub>OUT</sub> = 0 V; V <sub>CC</sub> = 13 V; T <sub>j</sub> = 125°C	0		3	
V <sub>F</sub>	Output - V <sub>CC</sub> diode voltage <sup>(1)</sup>	I <sub>OUT</sub> = -2 A; T <sub>j</sub> = 150°C			0.7	V

**Notes:**<sup>(1)</sup>For each channel.<sup>(2)</sup>PowerMOS leakage included.<sup>(3)</sup>Parameter specified by design; not subject to production test.**Table 6: Switching (V<sub>CC</sub> = 13 V; -40°C < T<sub>j</sub> < 150°C, unless otherwise specified)**

Symbol	Parameter	Test conditions	Min.	Typ.	Max.	Unit
t <sub>d(on)</sub> <sup>(1)</sup>	Turn-on delay time at T <sub>j</sub> = 25°C	R <sub>L</sub> = 6.5 Ω	10	35	120	μs
t <sub>d(off)</sub> <sup>(1)</sup>	Turn-off delay time at T <sub>j</sub> = 25°C		10	45	100	
(dV <sub>OUT</sub> /dt) <sub>on</sub> <sup>(1)</sup>	Turn-on voltage slope at T <sub>j</sub> = 25°C	R <sub>L</sub> = 6.5 Ω	0.1	0.28	0.7	V/μs
(dV <sub>OUT</sub> /dt) <sub>off</sub> <sup>(1)</sup>	Turn-off voltage slope at T <sub>j</sub> = 25°C		0.1	0.31	0.7	
W <sub>ON</sub>	Switching energy losses at turn-on (t <sub>won</sub> )	R <sub>L</sub> = 6.5 Ω	—	0.26	0.35 <sup>(2)</sup>	mJ
W <sub>OFF</sub>	Switching energy losses at turn-off (t <sub>woff</sub> )	R <sub>L</sub> = 6.5 Ω	—	0.23	0.31 <sup>(2)</sup>	mJ
t <sub>SKEW</sub> <sup>(1)</sup>	Differential Pulse skew (t <sub>PHL</sub> - t <sub>PLH</sub> )	R <sub>L</sub> = 6.5 Ω	-40	10	60	μs

**Notes:**<sup>(1)</sup>See [Figure 4: "Switching times and Pulse skew"](#).<sup>(2)</sup>Parameter guaranteed by design and characterization, not subject to production test

Table 7: Logic Inputs (7 V < V<sub>CC</sub> < 28 V; -40°C < T<sub>j</sub> < 150°C)

Symbol	Parameter	Test conditions	Min.	Typ.	Max.	Unit
<b>INPUT<sub>0,1,2,3</sub> characteristics</b>						
V <sub>IL</sub>	Input low level voltage				0.9	V
I <sub>IL</sub>	Low level input current	V <sub>IN</sub> = 0.9 V	1			μA
V <sub>IH</sub>	Input high level voltage		2.1			V
I <sub>IH</sub>	High level input current	V <sub>IN</sub> = 2.1 V			10	μA
V <sub>I(hyst)</sub>	Input hysteresis voltage		0.2			V
V <sub>ICL</sub>	Input clamp voltage	I <sub>IN</sub> = 1 mA	5.3		7.2	V
		I <sub>IN</sub> = -1 mA		-0.7		
<b>FaultRST characteristics</b>						
V <sub>FRL</sub>	Input low level voltage				0.9	V
I <sub>FRL</sub>	Low level input current	V <sub>IN</sub> = 0.9 V	1			μA
V <sub>FRH</sub>	Input high level voltage		2.1			V
I <sub>FRH</sub>	High level input current	V <sub>IN</sub> = 2.1 V			10	μA
V <sub>FR(hyst)</sub>	Input hysteresis voltage		0.2			V
V <sub>FRCL</sub>	Input clamp voltage	I <sub>IN</sub> = 1 mA	5.3		7.5	V
		I <sub>IN</sub> = -1 mA		-0.7		
<b>SEL<sub>0,1</sub> characteristics (7 V &lt; V<sub>CC</sub> &lt; 18 V)</b>						
V <sub>SELL</sub>	Input low level voltage				0.9	V
I <sub>SELL</sub>	Low level input current	V <sub>IN</sub> = 0.9 V	1			μA
V <sub>SELH</sub>	Input high level voltage		2.1			V
I <sub>SELH</sub>	High level input current	V <sub>IN</sub> = 2.1 V			10	μA
V <sub>SEL(hyst)</sub>	Input hysteresis voltage		0.2			V
V <sub>SELCL</sub>	Input clamp voltage	I <sub>IN</sub> = 1 mA	5.3		7.2	V
		I <sub>IN</sub> = -1 mA		-0.7		
<b>SEn characteristics (7 V &lt; V<sub>CC</sub> &lt; 18 V)</b>						
V <sub>SEnL</sub>	Input low level voltage				0.9	V
I <sub>SEnL</sub>	Low level input current	V <sub>IN</sub> = 0.9 V	1			μA
V <sub>SEnH</sub>	Input high level voltage		2.1			V
I <sub>SEnH</sub>	High level input current	V <sub>IN</sub> = 2.1 V			10	μA
V <sub>SEn(hyst)</sub>	Input hysteresis voltage		0.2			V
V <sub>SEnCL</sub>	Input clamp voltage	I <sub>IN</sub> = 1 mA	5.3		7.2	V
		I <sub>IN</sub> = -1 mA		-0.7		

Table 8: Protections (7 V < V<sub>CC</sub> < 18 V; -40°C < T<sub>j</sub> < 150°C)

Symbol	Parameter	Test conditions	Min.	Typ.	Max.	Unit
I <sub>LIMH</sub>	DC short circuit current	V <sub>CC</sub> = 13 V	21	27	38	A
		4 V < V <sub>CC</sub> < 18 V <sup>(1)</sup>			38	
I <sub>LIML</sub>	Short circuit current during thermal cycling	V <sub>CC</sub> = 13 V; T <sub>R</sub> < T <sub>j</sub> < T <sub>TSD</sub>		9		

Symbol	Parameter	Test conditions	Min.	Typ.	Max.	Unit
T <sub>TSD</sub>	Shutdown temperature		150	175	200	°C
T <sub>R</sub>	Reset temperature <sup>(1)</sup>		T <sub>RS</sub> + 1	T <sub>RS</sub> + 7		
T <sub>RS</sub>	Thermal reset of fault diagnostic indication	V <sub>FR</sub> = 0 V; V <sub>SEn</sub> = 5 V;	135			
T <sub>HYST</sub>	Thermal hysteresis (T <sub>TSD</sub> - T <sub>R</sub> ) <sup>(1)</sup>			7		
ΔT <sub>J_SD</sub>	Dynamic temperature	T <sub>j</sub> = -40°C; V <sub>CC</sub> = 13 V		60		K
t <sub>LATCH_RST</sub>	Fault reset time for output unlatch <sup>(1)</sup>	V <sub>FR</sub> = 5 V to 0 V; V <sub>SEn</sub> = 5 V • E.g. Ch0 V <sub>IN0</sub> = 5 V; V <sub>SELO,1</sub> = 0 V	3	10	20	μs
V <sub>DEMAG</sub>	Turn-off output voltage clamp	I <sub>OUT</sub> = 2 A; L = 6 mH; T <sub>j</sub> = -40°C	V <sub>CC</sub> - 38			V
		I <sub>OUT</sub> = 2 A; L = 6 mH; T <sub>j</sub> = 25°C to 150°C	V <sub>CC</sub> - 41	V <sub>CC</sub> - 46	V <sub>CC</sub> - 52	V
V <sub>ON</sub>	Output voltage drop limitation	I <sub>OUT</sub> = 0.2 A		20		mV

**Notes:**

<sup>(1)</sup>Parameter guaranteed by design and characterization; not subject to production test.

**Table 9: CurrentSense (7 V < V<sub>CC</sub> < 18 V; -40°C < T<sub>j</sub> < 150°C)**

Symbol	Parameter	Test conditions	Min.	Typ.	Max.	Unit
V <sub>SENSE_CL</sub>	Current sense clamp voltage	V <sub>SEn</sub> = 0 V; I <sub>SENSE</sub> = 1 mA	-17		-12	V
		V <sub>SEn</sub> = 0 V; I <sub>SENSE</sub> = -1 mA		7		
<b>Current Sense characteristics</b>						
K <sub>OL</sub>	I <sub>OUT</sub> /I <sub>SENSE</sub>	I <sub>OUT</sub> = 0.01 A; V <sub>SENSE</sub> = 0.5 V; V <sub>SEn</sub> = 5 V	425			
dK <sub>cal</sub> /K <sub>cal</sub> <sup>(1)(2)</sup>	Current sense ratio drift at calibration point	I <sub>OUT</sub> = 0.01 A to 0.05 A; I <sub>cal</sub> = 30 A; V <sub>SENSE</sub> = 0.5 V; V <sub>SEn</sub> = 5 V	-30		30	%
K <sub>LLED</sub>	I <sub>OUT</sub> /I <sub>SENSE</sub>	I <sub>OUT</sub> = 0.05 A; V <sub>SENSE</sub> = 0.5 V; V <sub>SEn</sub> = 5 V	530	1390	2120	
dK <sub>LLED</sub> /K <sub>LLED</sub> <sup>(1)(2)</sup>	Current sense ratio drift	I <sub>OUT</sub> = 0.05 A; V <sub>SENSE</sub> = 0.5 V; V <sub>SEn</sub> = 5 V	-30		30	%
K <sub>0</sub>	I <sub>OUT</sub> /I <sub>SENSE</sub>	I <sub>OUT</sub> = 0.2 A; V <sub>SENSE</sub> = 0.5 V; V <sub>SEn</sub> = 5 V	730	1280	1700	
dK <sub>0</sub> /K <sub>0</sub> <sup>(1)(2)</sup>	Current sense ratio drift	I <sub>OUT</sub> = 0.2 A; V <sub>SENSE</sub> = 0.5 V; V <sub>SEn</sub> = 5 V	-25		25	%
K <sub>1</sub>	I <sub>OUT</sub> /I <sub>SENSE</sub>	I <sub>OUT</sub> = 0.4 A; V <sub>SENSE</sub> = 4 V; V <sub>SEn</sub> = 5 V	830	1180	1545	
dK <sub>1</sub> /K <sub>1</sub> <sup>(1)(2)</sup>	Current sense ratio drift	I <sub>OUT</sub> = 0.4 A; V <sub>SENSE</sub> = 4 V; V <sub>SEn</sub> = 5 V	-20		20	%
K <sub>2</sub>	I <sub>OUT</sub> /I <sub>SENSE</sub>	I <sub>OUT</sub> = 1.5 A; V <sub>SENSE</sub> = 4 V; V <sub>SEn</sub> = 5 V	885	1120	1335	

Symbol	Parameter	Test conditions	Min.	Typ.	Max.	Unit
$dK_2/K_2^{(1)(2)}$	Current sense ratio drift	$I_{OUT} = 1.5 \text{ A}; V_{SENSE} = 4 \text{ V}; V_{SEn} = 5 \text{ V}$	-15		15	%
$K_3$	$I_{OUT}/I_{SENSE}$	$I_{OUT} = 4.5 \text{ A}; V_{SENSE} = 4 \text{ V}; V_{SEn} = 5 \text{ V}$	990	1110	1210	
$dK_3/K_3^{(1)(2)}$	Current sense ratio drift	$I_{OUT} = 4.5 \text{ A}; V_{SENSE} = 4 \text{ V}; V_{SEn} = 5 \text{ V}$	-10		10	%
$I_{SENSE0}$	Current sense leakage current	Current sense disabled: $V_{SEn} = 0 \text{ V};$	0		0.5	$\mu\text{A}$
		Current sense disabled: $-1 \text{ V} < V_{SENSE} < 5 \text{ V}^{(1)}$	-0.5		0.5	
		Current sense enabled: $V_{SEn} = 5 \text{ V}$ All channels ON; $I_{OUTX} = 0 \text{ A};$ ChX diagnostic selected: • E.g. Ch0: $V_{IN0,1,2,3} = 5 \text{ V}; V_{SELO} = 0 \text{ V};$ $V_{SEL1} = 0 \text{ V}; I_{OUT0} = 0 \text{ A};$ $I_{OUT1,2,3} = 2 \text{ A}$	0		2	
		Current sense enabled: $V_{SEn} = 5 \text{ V};$ ChX OFF; ChX diagnostic selected: • E.g. Ch0: $V_{IN0} = 0 \text{ V}; V_{IN1,2,3} = 0 \text{ V};$ $V_{SELO} = 5 \text{ V}; V_{SEL1} = 0 \text{ V};$ $I_{OUT1,2,3} = 2 \text{ A}$	0		2	
$V_{OUT\_MSD}^{(1)}$	Output Voltage for Current sense shutdown	$V_{SEn} = 5 \text{ V}; R_{SENSE} = 2.7 \text{ k}\Omega$ • E.g. Ch0: $V_{IN0} = 5 \text{ V}; V_{SELO} = 0 \text{ V};$ $V_{SEL1} = 0 \text{ V}; I_{OUT0} = 2 \text{ A}$		5		V
$V_{SENSE\_SAT}$	CS saturation voltage	$V_{CC} = 7 \text{ V}; R_{SENSE} = 2.7 \text{ k}\Omega;$ $V_{SEn} = 5 \text{ V}; V_{IN0} = 5 \text{ V};$ $V_{SELO,1} = 0 \text{ V}; I_{OUT0} = 4.5 \text{ A};$ $T_j = 150^\circ\text{C}$	5			V
$I_{SENSE\_SAT}^{(1)}$	CS saturation current	$V_{CC} = 7 \text{ V}; V_{SENSE} = 4 \text{ V};$ $V_{IN0} = 5 \text{ V}; V_{SEn} = 5 \text{ V};$ $V_{SELO,1} = 0 \text{ V}; T_j = 150^\circ\text{C}$	4			mA
$I_{OUT\_SAT}^{(1)}$	Output saturation current	$V_{CC} = 7 \text{ V}; V_{SENSE} = 4 \text{ V};$ $V_{IN0} = 5 \text{ V}; V_{SEn} = 5 \text{ V};$ $V_{SELO,1} = 0 \text{ V}; T_j = 150^\circ\text{C}$	4.8			A
<b>OFF-state diagnostic</b>						
$V_{OL}$	OFF-state open-load voltage detection threshold	$V_{SEn} = 5 \text{ V};$ ChX OFF; ChX diagnostic selected • E.g. Ch0 $V_{IN0} = 0 \text{ V}; V_{SELO,1} = 0 \text{ V}$	2	3	4	V
$I_{L(off2)}$	OFF-state output sink current	$V_{IN} = 0 \text{ V}; V_{OUT} = V_{OL};$ $T_j = -40^\circ\text{C} \text{ to } 125^\circ\text{C}$	-100		-15	$\mu\text{A}$

Symbol	Parameter	Test conditions	Min.	Typ.	Max.	Unit
$t_{DSTKON}$	OFF-state diagnostic delay time from falling edge of INPUT (see <a href="#">Figure 6: "TDSKON"</a> )	$V_{SEN} = 5\text{ V}$ ; $Ch_X$ ON to OFF transition; $Ch_X$ diagnostic selected: <ul style="list-style-type: none"> <li>E.g: <math>Ch_0</math>  <math>V_{IN0} = 5\text{ V}</math> to <math>0\text{ V}</math>;  <math>V_{SELO,1} = 0\text{ V}</math>; <math>V_{OUT0} = 4\text{ V}</math>;  <math>I_{OUT0} = 0\text{ A}</math></li> </ul>	100	350	700	$\mu\text{s}$
$t_{D\_OL\_V}$	Settling time for valid OFF-state open-load diagnostic indication from rising edge of $SEn$	$V_{IN0,1,2,3} = 0\text{ V}$ ; $V_{FR} = 0\text{ V}$ ; $V_{SELO,1} = 0\text{ V}$ ; $V_{OUT0} = 4\text{ V}$ ; $V_{SEN} = 0\text{ V}$ to $5\text{ V}$			60	$\mu\text{s}$
$t_{D\_VOL}$	OFF-state diagnostic delay time from rising edge of $V_{OUT}$	$V_{SEN} = 5\text{ V}$ ; $Ch_X$ OFF; $Ch_X$ diagnostic selected: <ul style="list-style-type: none"> <li>E.g: <math>Ch_0</math>  <math>V_{IN0} = 0\text{ V}</math>; <math>V_{SELO,1} = 0\text{ V}</math>;  <math>V_{OUT0} = 0\text{ V}</math> to <math>4\text{ V}</math></li> </ul>		5	30	$\mu\text{s}$
<b>Fault diagnostic feedback (see <a href="#">Table 10: "Truth table"</a>)</b>						
$V_{SENSEH}$	Current sense output voltage in fault condition	$V_{CC} = 13\text{ V}$ ; $R_{SENSE} = 1\text{ k}\Omega$ <ul style="list-style-type: none"> <li>E.g: <math>Ch_0</math> in open load  <math>V_{IN0} = 0\text{ V}</math>; <math>V_{SEN} = 5\text{ V}</math>;  <math>V_{SELO,1} = 0\text{ V}</math>; <math>I_{OUT0} = 0\text{ A}</math>;  <math>V_{OUT0} = 4\text{ V}</math></li> </ul>	5		6.6	V
$I_{SENSEH}$	Current sense output current in fault condition	$V_{CC} = 13\text{ V}$ ; $V_{SENSE} = 5\text{ V}$	7	20	30	mA
<b>Current sense timings (current sense mode - see <a href="#">Figure 5: "Current sense timings (current sense mode)"</a>)</b>						
$t_{DSSENSE1H}$	Current sense settling time from rising edge of $SEn$	$V_{IN} = 5\text{ V}$ ; $V_{SEN} = 0\text{ V}$ to $5\text{ V}$ ; $R_{SENSE} = 1\text{ k}\Omega$ ; $R_L = 6.5\ \Omega$			60	$\mu\text{s}$
$t_{DSSENSE1L}$	Current sense disable delay time from falling edge of $SEn$	$V_{SEN} = 5\text{ V}$ to $0\text{ V}$ ; $R_{SENSE} = 1\text{ k}\Omega$ ; $R_L = 6.5\ \Omega$		5	20	$\mu\text{s}$
$t_{DSSENSE2H}$	Current sense settling time from rising edge of INPUT	$V_{IN} = 0\text{ V}$ to $5\text{ V}$ ; $V_{SEN} = 5\text{ V}$ ; $R_{SENSE} = 1\text{ k}\Omega$ ; $R_L = 6.5\ \Omega$		100	250	$\mu\text{s}$
$\Delta t_{DSSENSE2H}$	Current sense settling time from rising edge of $I_{OUT}$ (dynamic response to a step change of $I_{OUT}$ )	$V_{IN} = 5\text{ V}$ ; $V_{SEN} = 5\text{ V}$ ; $R_{SENSE} = 1\text{ k}\Omega$ ; $I_{SENSE} = 90\%$ of $I_{SENSEMAX}$ ; $R_L = 6.5\ \Omega$			100	$\mu\text{s}$
$t_{DSSENSE2L}$	Current sense turn-off delay time from falling edge of INPUT	$V_{IN} = 5\text{ V}$ to $0\text{ V}$ ; $V_{SEN} = 5\text{ V}$ ; $R_{SENSE} = 1\text{ k}\Omega$ ; $R_L = 6.5\ \Omega$		50	250	$\mu\text{s}$

**Notes:**

(1)Parameter defined by design. Not subject to production test.

(2)All values refer to  $V_{CC} = 13\text{ V}$ ;  $T_j = 25^\circ\text{C}$ , unless otherwise specified.

Figure 4: Switching times and Pulse skew

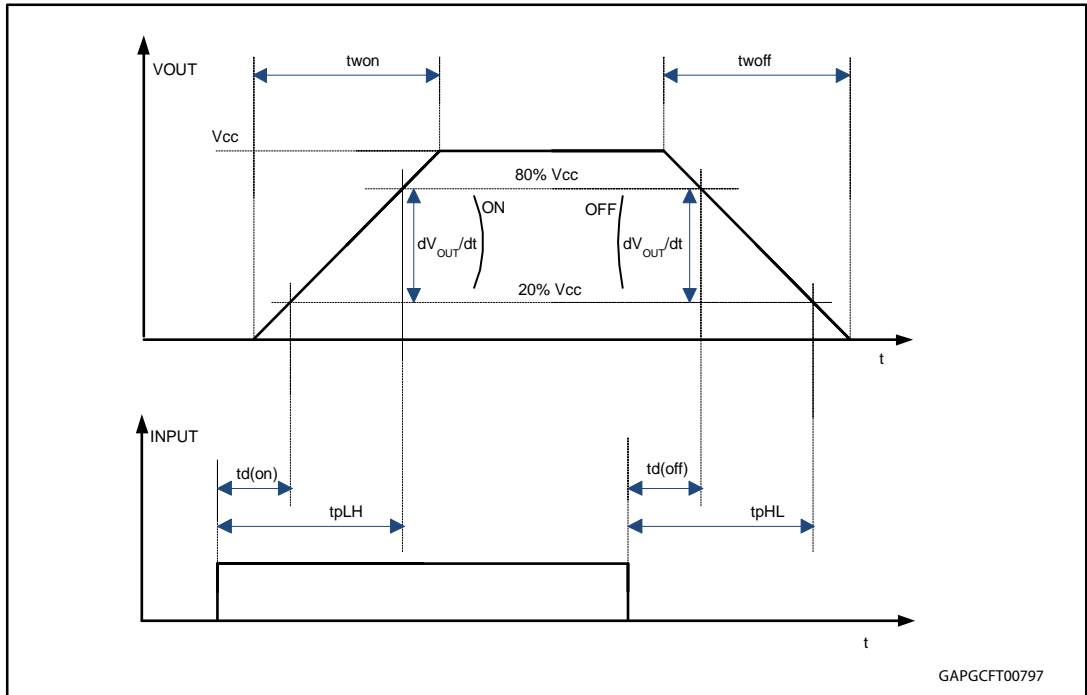


Figure 5: Current sense timings (current sense mode)

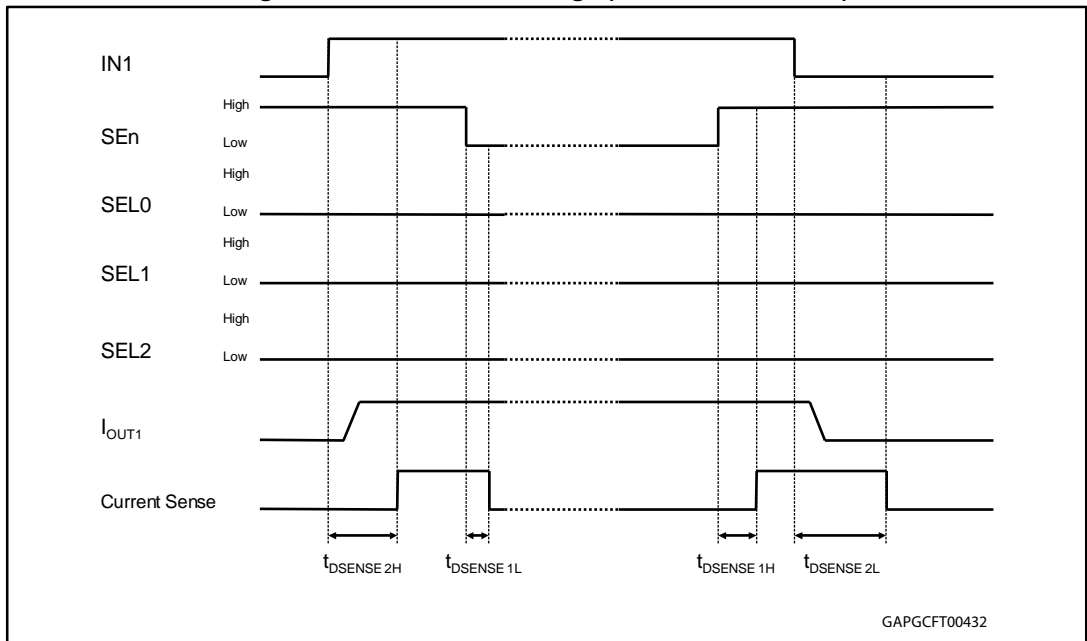


Figure 6: TDSKON

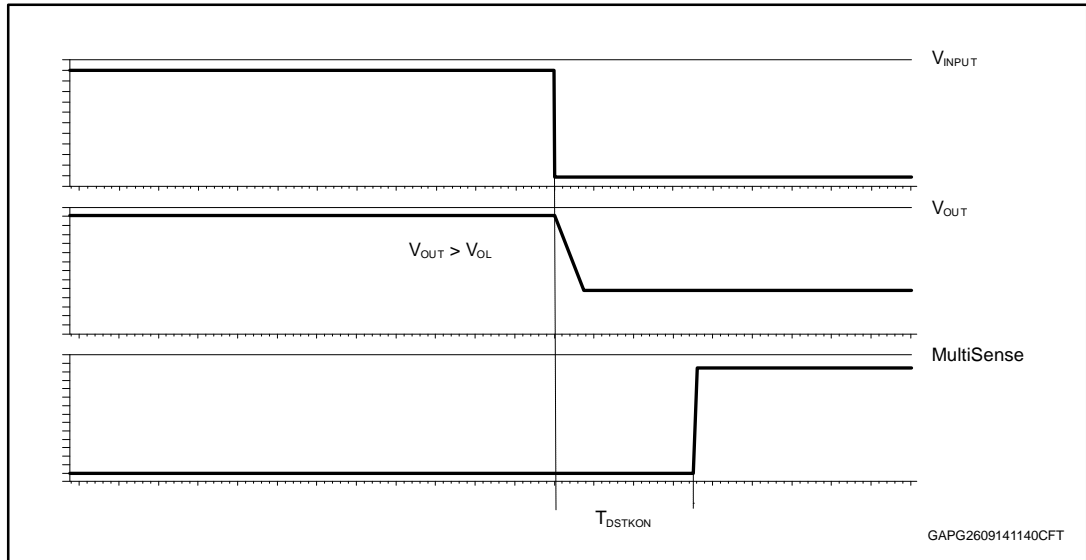


Table 10: Truth table

Mode	Conditions	IN <sub>x</sub>	FR	SEn	SEL <sub>x</sub>	OUT <sub>x</sub>	Current sense	Comments
Standby	All logic inputs low	L	L	L	L	L	Hi-Z	Low quiescent current consumption
Normal	Nominal load connected; $T_j < 150^\circ\text{C}$	L	X	See (1)		L	See (1)	
		H	L			H	See (1)	Outputs configured for auto-restart
		H	H			H	See (1)	Outputs configured for Latch-off
Overload	Overload or short to GND causing: $T_j > T_{TSD}$ or $\Delta T_j > \Delta T_{i\_SD}$	L	X	See (1)		L	See (1)	
		H	L			H	See (1)	Output cycles with temperature hysteresis
		H	H			L	See (1)	Output latches-off
Under-voltage	$V_{CC} < V_{USD}$ (falling)	X	X	X	X	L L	Hi-Z Hi-Z	Re-start when $V_{CC} > V_{USD} + V_{USDhyst}$ (rising)
OFF-state diagnostics	Short to $V_{CC}$	L	X	See (1)		H	See (1)	
	Open-load	L	X			H	See (1)	External pull-up
Negative output voltage	Inductive loads turn-off	L	X	See (1)		< 0 V	See (1)	

Notes:

(1) Refer to [Table 11: "Current sense multiplexer addressing"](#)

Table 11: Current sense multiplexer addressing

SEn	SEL <sub>1</sub>	SEL <sub>0</sub>	MUX channel	Current sense output			
				Nomal mode	Overload	OFF-state diag. <i>(1)(2)(3)</i>	Negative output
L	X	X		Hi-Z			
H	L	L	Channel 0 diagnostic	$I_{SENSE} = 1/K * I_{OUT0}$	$V_{SENSE} = V_{SENSEH}$	$V_{SENSE} = V_{SENSEH}$	Hi-Z
H	L	H	Channel 1 diagnostic	$I_{SENSE} = 1/K * I_{OUT1}$	$V_{SENSE} = V_{SENSEH}$	$V_{SENSE} = V_{SENSEH}$	Hi-Z
H	H	L	Channel 2 diagnostic	$I_{SENSE} = 1/K * I_{OUT2}$	$V_{SENSE} = V_{SENSEH}$	$V_{SENSE} = V_{SENSEH}$	Hi-Z
H	H	H	Channel 3 diagnostic	$I_{SENSE} = 1/K * I_{OUT3}$	$V_{SENSE} = V_{SENSEH}$	$V_{SENSE} = V_{SENSEH}$	Hi-Z

**Notes:**

- (1) In case the output channel corresponding to the selected MUX channel is latched off while the relevant input is low, CS pin delivers feedback according to OFF-State diagnostic.
- (2) Example 1: FR = 1; IN<sub>0</sub> = 0; OUT<sub>0</sub> = L (latched); MUX channel = channel 0 diagnostic; CS = 0
- (3) Example 2: FR = 1; IN<sub>0</sub> = 0; OUT<sub>0</sub> = latched, V<sub>OUT0</sub> > V<sub>OL</sub>; MUX channel = channel 0 diagnostic; CS = V<sub>SENSEH</sub>

## 2.4 Waveforms

Figure 7: Latch functionality - behavior in hard short circuit condition (T<sub>AMB</sub> << T<sub>TSD</sub>)

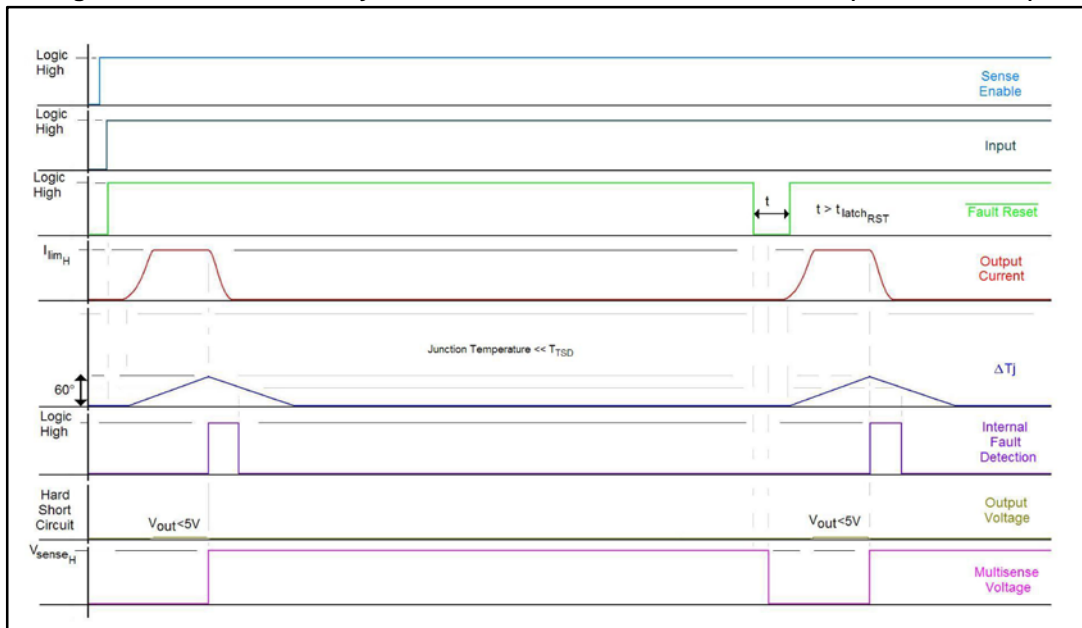




Figure 8: Latch functionality - behavior in hard short circuit condition

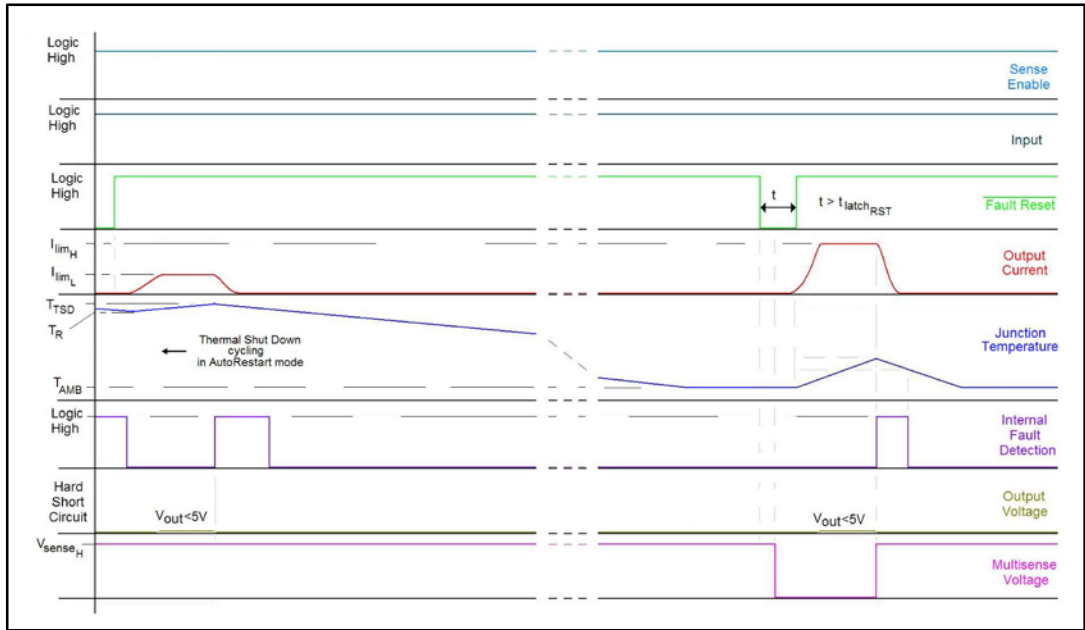


Figure 9: Latch functionality - behavior in hard short circuit condition (autorestart mode + latch off)

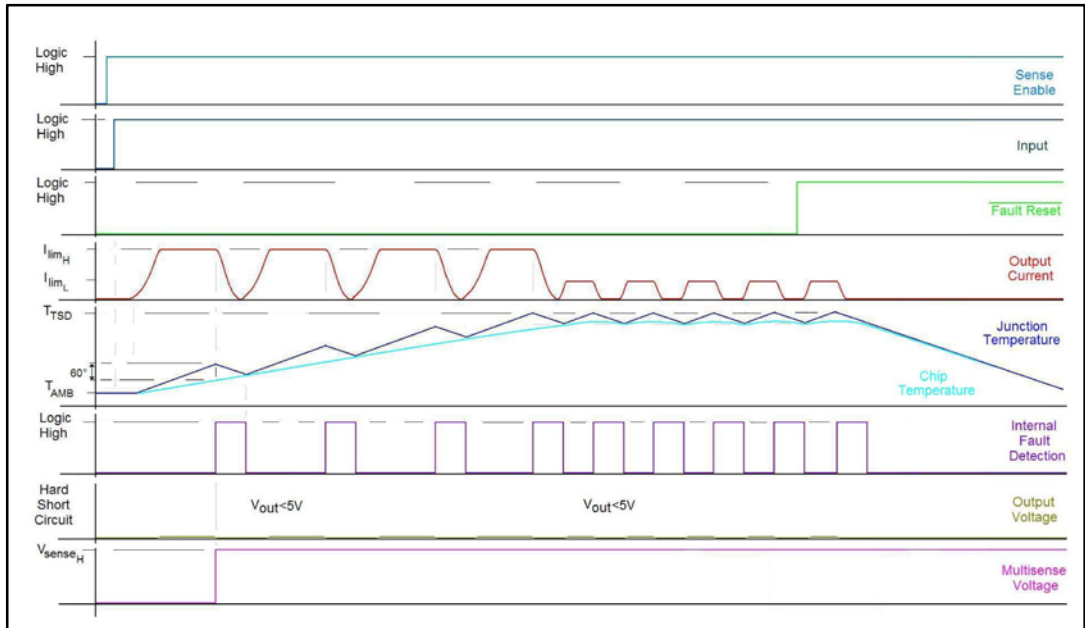


Figure 10: Standby mode activation

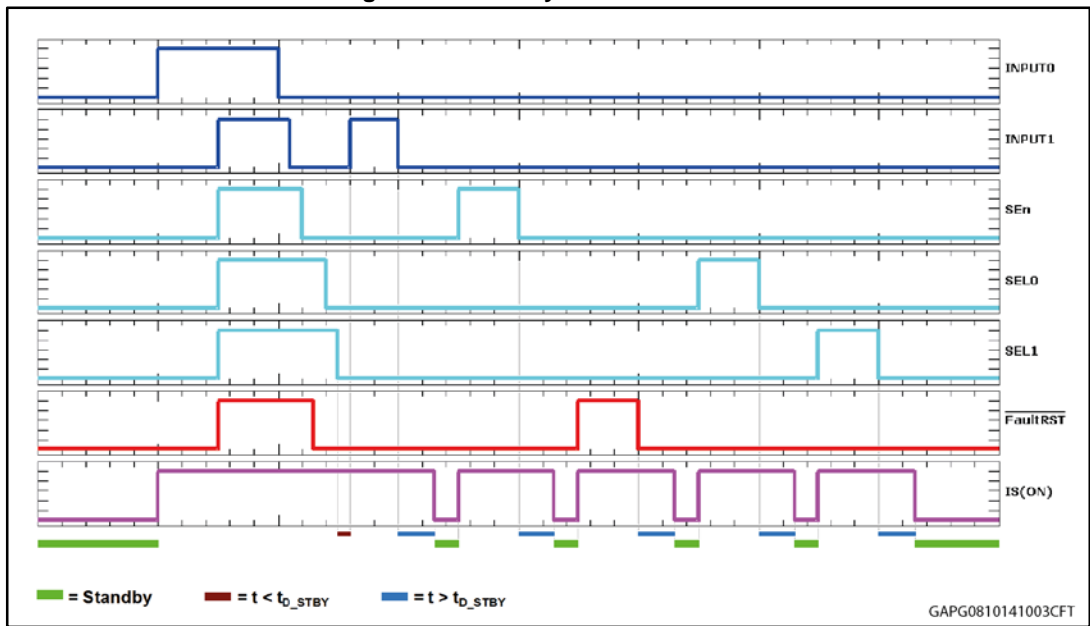
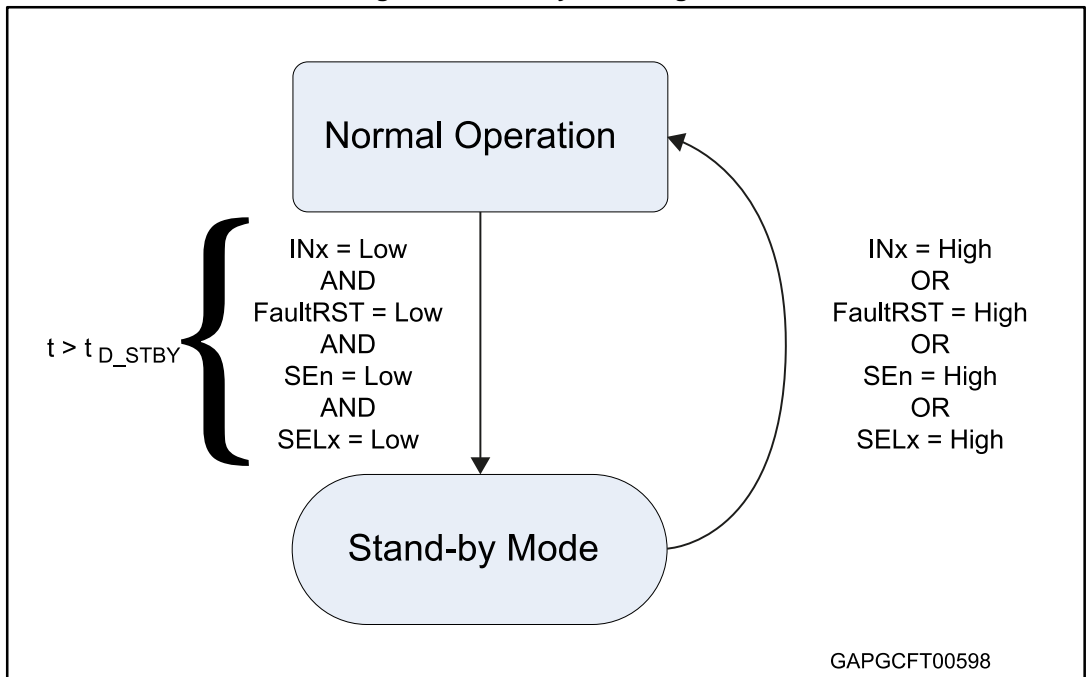
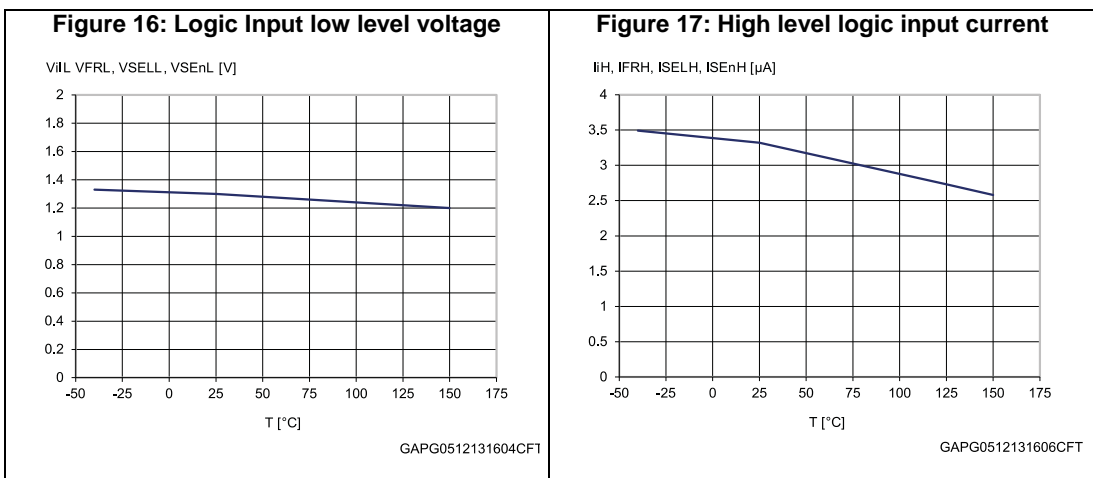
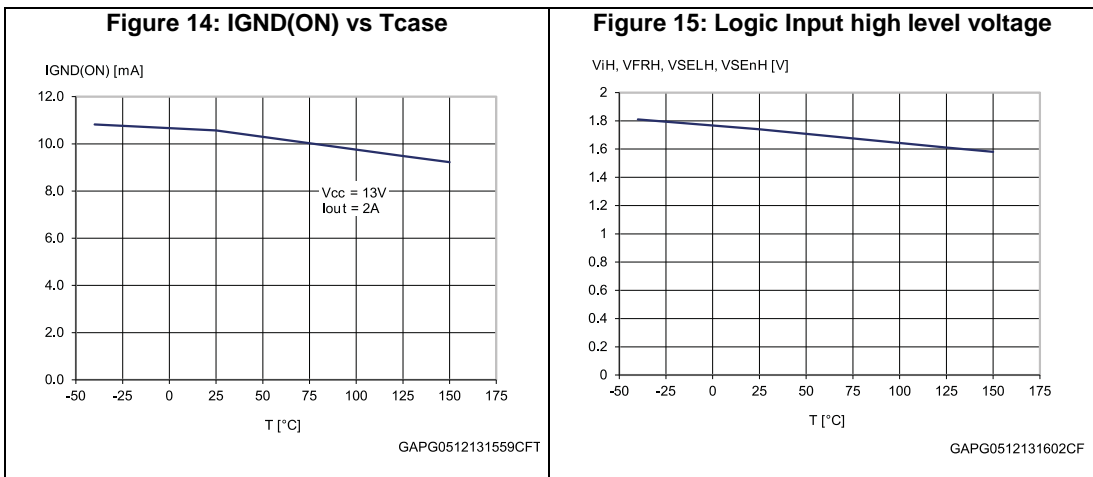
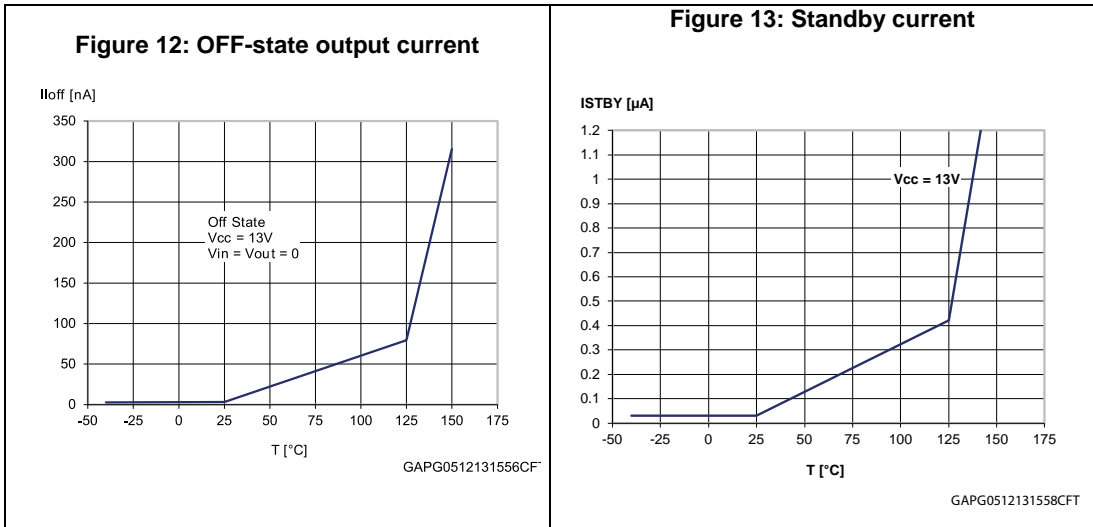
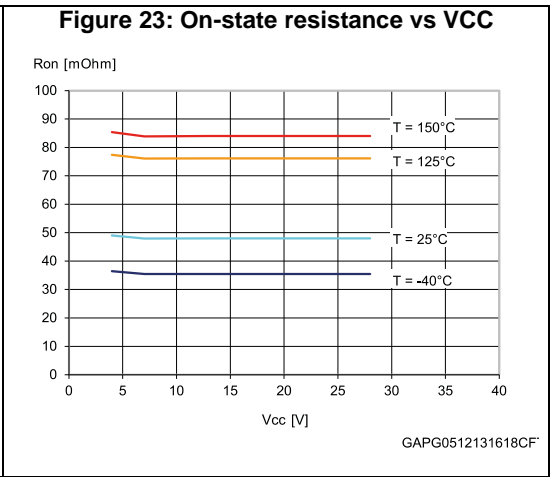
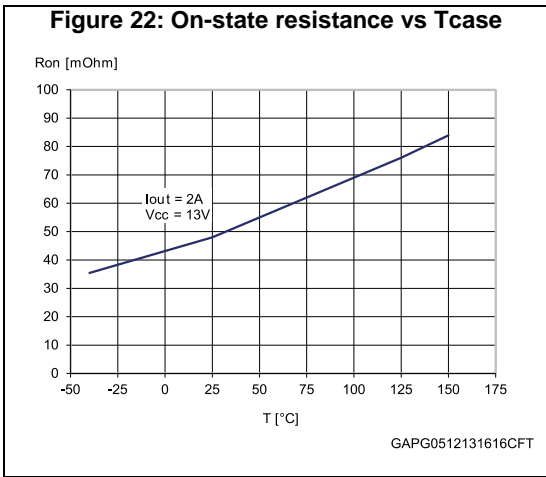
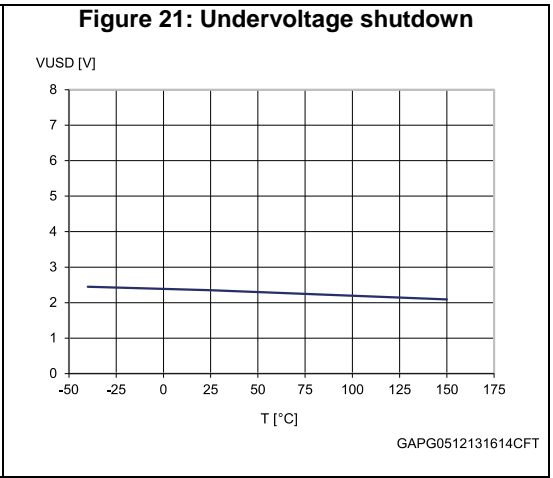
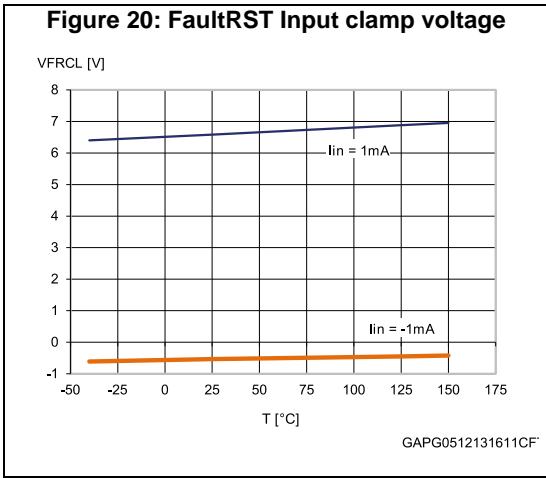
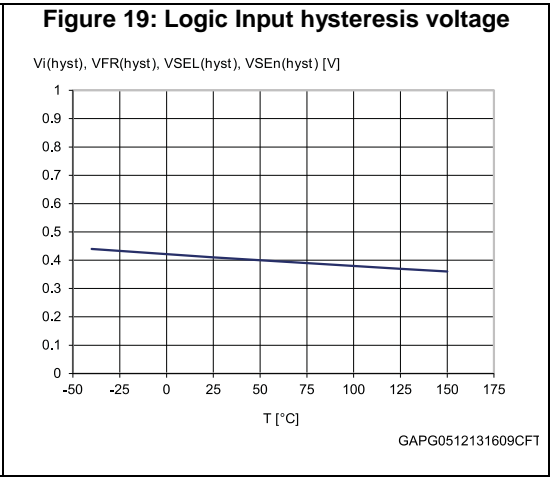
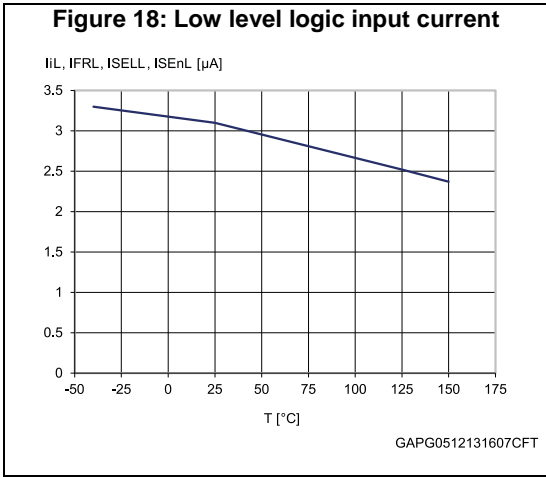


Figure 11: Standby state diagram

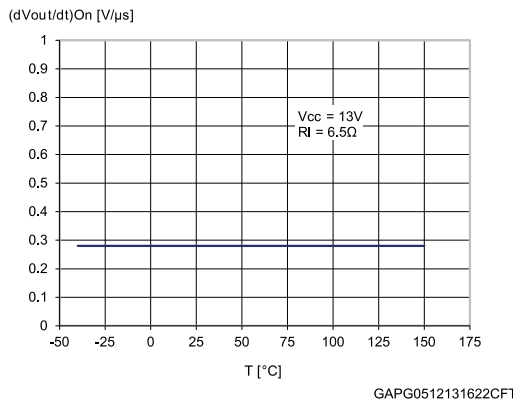


## 2.5 Electrical characteristics curves

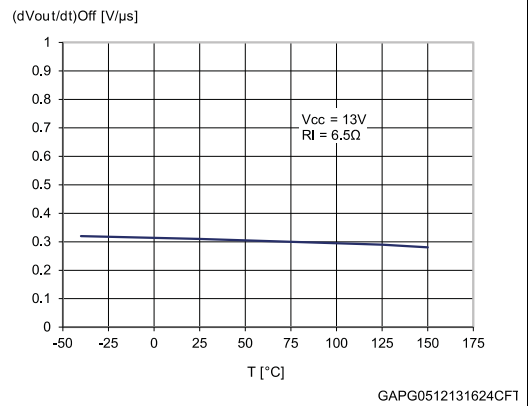




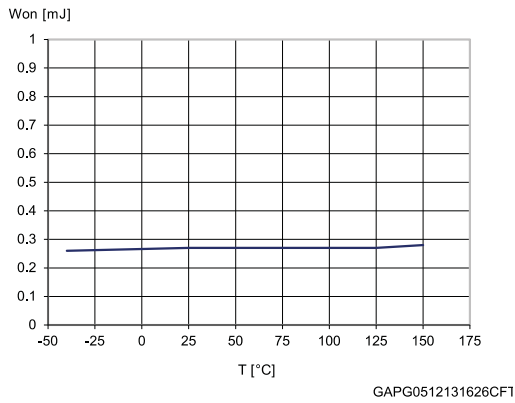
**Figure 24: Turn-on voltage slope**



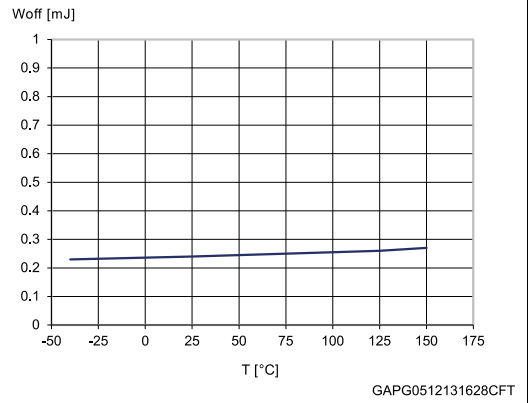
**Figure 25: Turn-off voltage slope**



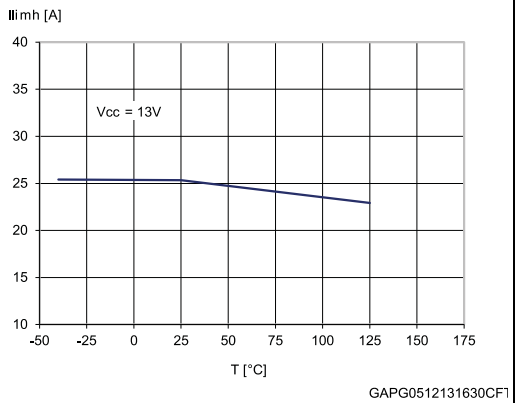
**Figure 26: Won vs Tcase**



**Figure 27: Woff vs Tcase**



**Figure 28: ILIMH vs. Tcase**



**Figure 29: OFF-state open-load voltage detection threshold**

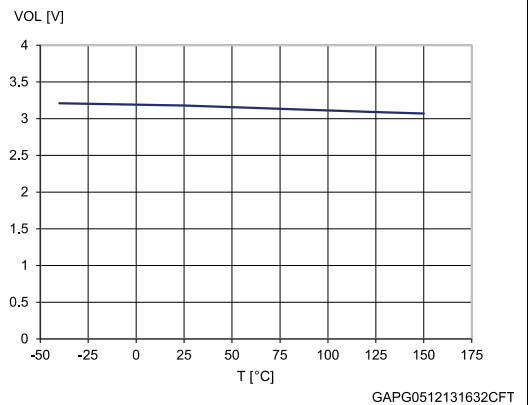


Figure 30: Vsense clamp vs. Tcase

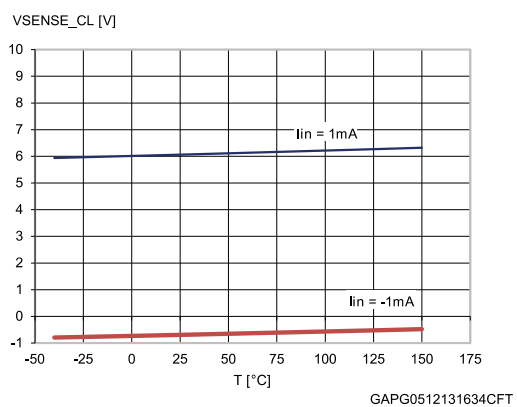
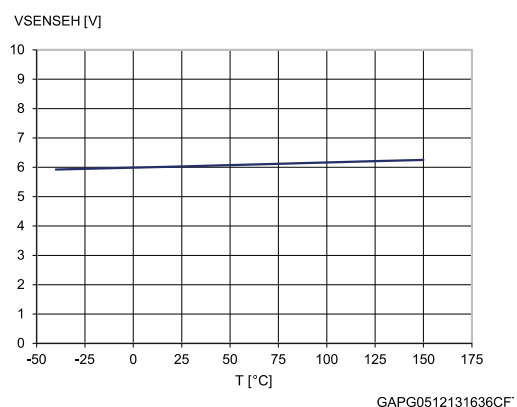


Figure 31: Vsenseh vs. Tcase



## 3 Protections

### 3.1 Power limitation

The basic working principle of this protection consists of an indirect measurement of the junction temperature swing  $\Delta T_j$  through the direct measurement of the spatial temperature gradient on the device surface in order to automatically shut off the output MOSFET as soon as  $\Delta T_j$  exceeds the safety level of  $\Delta T_{j\_SD}$ . According to the voltage level on the FaultRST pin, the output MOSFET switches on and cycles with a thermal hysteresis according to the maximum instantaneous power which can be handled (FaultRST = Low) or remains off (FaultRST = High). The protection prevents fast thermal transient effects and, consequently, reduces thermo-mechanical fatigue.

### 3.2 Thermal shutdown

In case the junction temperature of the device exceeds the maximum allowed threshold (typically 175°C), it automatically switches off and the diagnostic indication is triggered. According to the voltage level on the FaultRST pin, the device switches on again as soon as its junction temperature drops to  $T_R$  (FaultRST = Low) or remains off (FaultRST = High).

### 3.3 Current limitation

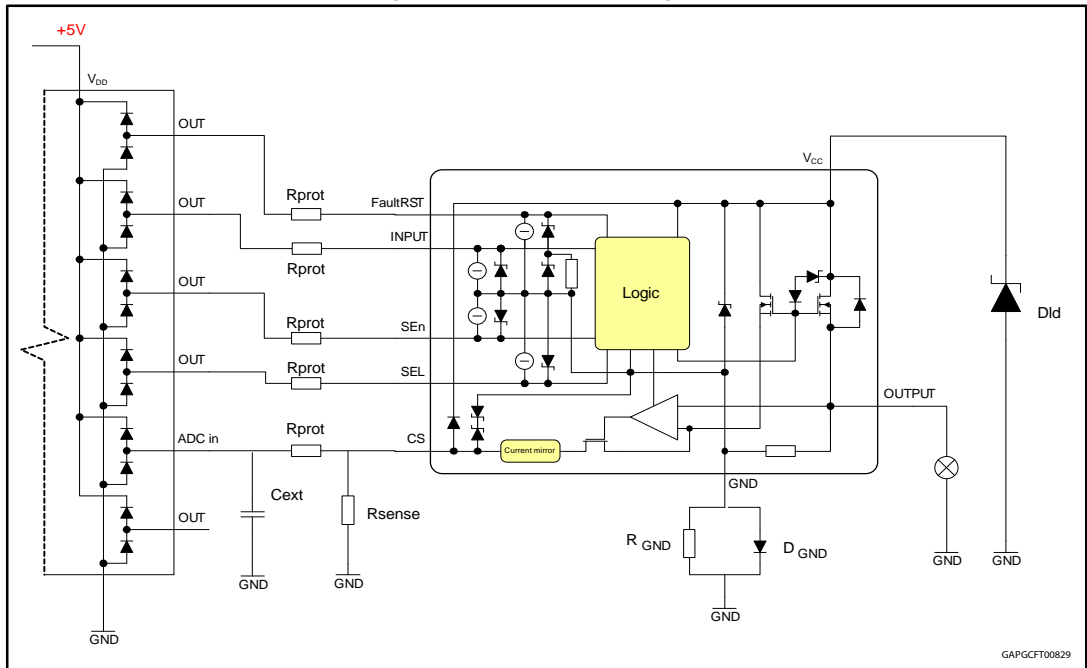
The device is equipped with an output current limiter in order to protect the silicon as well as the other components of the system (e.g. bonding wires, wiring harness, connectors, loads, etc.) from excessive current flow. Consequently, in case of short circuit, overload or during load power-up, the output current is clamped to a safety level,  $I_{LIMH}$ , by operating the output power MOSFET in the active region.

### 3.4 Negative voltage clamp

In case the device drives inductive load, the output voltage reaches a negative value during turn off. A negative voltage clamp structure limits the maximum negative voltage to a certain value,  $V_{DEMAG}$ , allowing the inductor energy to be dissipated without damaging the device.

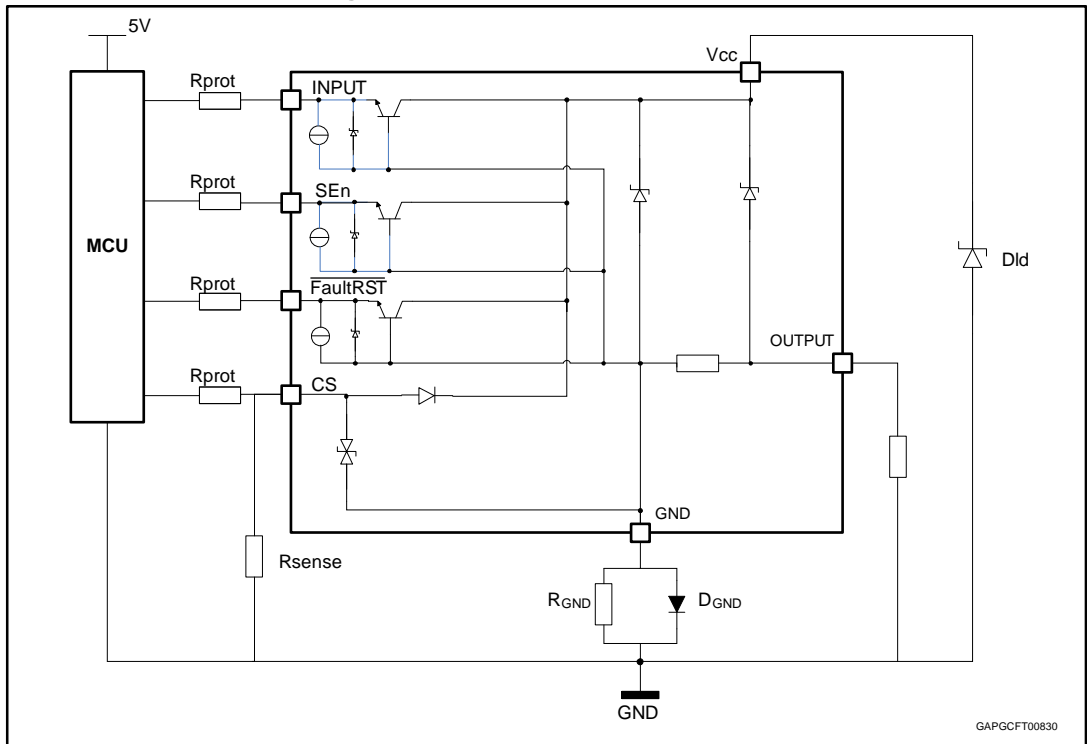
# 4 Application information

Figure 32: Application diagram



## 4.1 GND protection network against reverse battery

Figure 33: Simplified internal structure





### 4.1.1 Diode (DGND) in the ground line

A resistor (typ.  $R_{\text{GND}} = 4.7 \text{ k}\Omega$ ) should be inserted in parallel to  $D_{\text{GND}}$  if the device drives an inductive load.

This small signal diode can be safely shared amongst several different HSDs. Also in this case, the presence of the ground network produces a shift ( $\approx 600 \text{ mV}$ ) in the input threshold and in the status output values if the microprocessor ground is not common to the device ground. This shift does not vary if more than one HSD shares the same diode/resistor network.

## 4.2 Immunity against transient electrical disturbances

The immunity of the device against transient electrical emissions, conducted along the supply lines and injected into the  $V_{\text{CC}}$  pin, is tested in accordance with ISO 7637-2:2011 (E) and ISO 16750-2:2010.

The related function performance status classification is shown in [Table 12: "ISO 7637-2 - electrical transient conduction along supply line"](#).

Test pulses are applied directly to DUT (Device Under Test) both in ON and OFF-state and in accordance to ISO 7637-2:2011(E), chapter 4. The DUT is intended as the present device only, without components and accessed through  $V_{\text{CC}}$  and GND terminals.

Status II is defined in ISO 7637-1 Function Performance Status Classification (FPSC) as follows: "The function does not perform as designed during the test but returns automatically to normal operation after the test".

**Table 12: ISO 7637-2 - electrical transient conduction along supply line**

Test Pulse 2011(E)	Test pulse severity level with Status II functional performance status		Minimum number of pulses or test time	Burst cycle / pulse repetition time		Pulse duration and pulse generator internal impedance
	Level	$U_s^{(1)}$		min	max	
1	III	-112V	500 pulses	0,5 s		2ms, 10 $\Omega$
2a	III	+55V	500 pulses	0,2 s	5 s	50 $\mu$ s, 2 $\Omega$
3a	IV	-220V	1h	90 ms	100 ms	0.1 $\mu$ s, 50 $\Omega$
3b	IV	+150V	1h	90 ms	100 ms	0.1 $\mu$ s, 50 $\Omega$
4 <sup>(2)</sup>	IV	-7V	1 pulse			100ms, 0.01 $\Omega$
<b>Load dump according to ISO 16750-2:2010</b>						
Test B <sup>(3)</sup>		40V	5 pulse	1 min		400ms, 2 $\Omega$

**Notes:**

<sup>(1)</sup> $U_s$  is the peak amplitude as defined for each test pulse in ISO 7637-2:2011(E), chapter 5.6.

<sup>(2)</sup>Test pulse from ISO 7637-2:2004(E).

<sup>(3)</sup>With 40 V external suppressor referred to ground ( $-40^\circ\text{C} < T_j < 150^\circ\text{C}$ ).

## 4.3 MCU I/Os protection

If a ground protection network is used and negative transients are present on the  $V_{\text{CC}}$  line, the control pins will be pulled negative. ST suggests to insert a resistor ( $R_{\text{prot}}$ ) in line both to prevent the microcontroller I/O pins to latch-up and to protect the HSD inputs.

The value of these resistors is a compromise between the leakage current of microcontroller and the current required by the HSD I/Os (Input levels compatibility) with the latch-up limit of microcontroller I/Os.

**Equation**

$$V_{CCpeak} / I_{latchup} \leq R_{prot} \leq (V_{OH\mu C} - V_{IH} - V_{GND}) / I_{IHmax}$$

Calculation example:

For  $V_{CCpeak} = -150\text{ V}$ ;  $I_{latchup} \geq 20\text{ mA}$ ;  $V_{OH\mu C} \geq 4.5\text{ V}$

$7.5\text{ k}\Omega \leq R_{prot} \leq 140\text{ k}\Omega$ .

Recommended values:  $R_{prot} = 15\text{ k}\Omega$

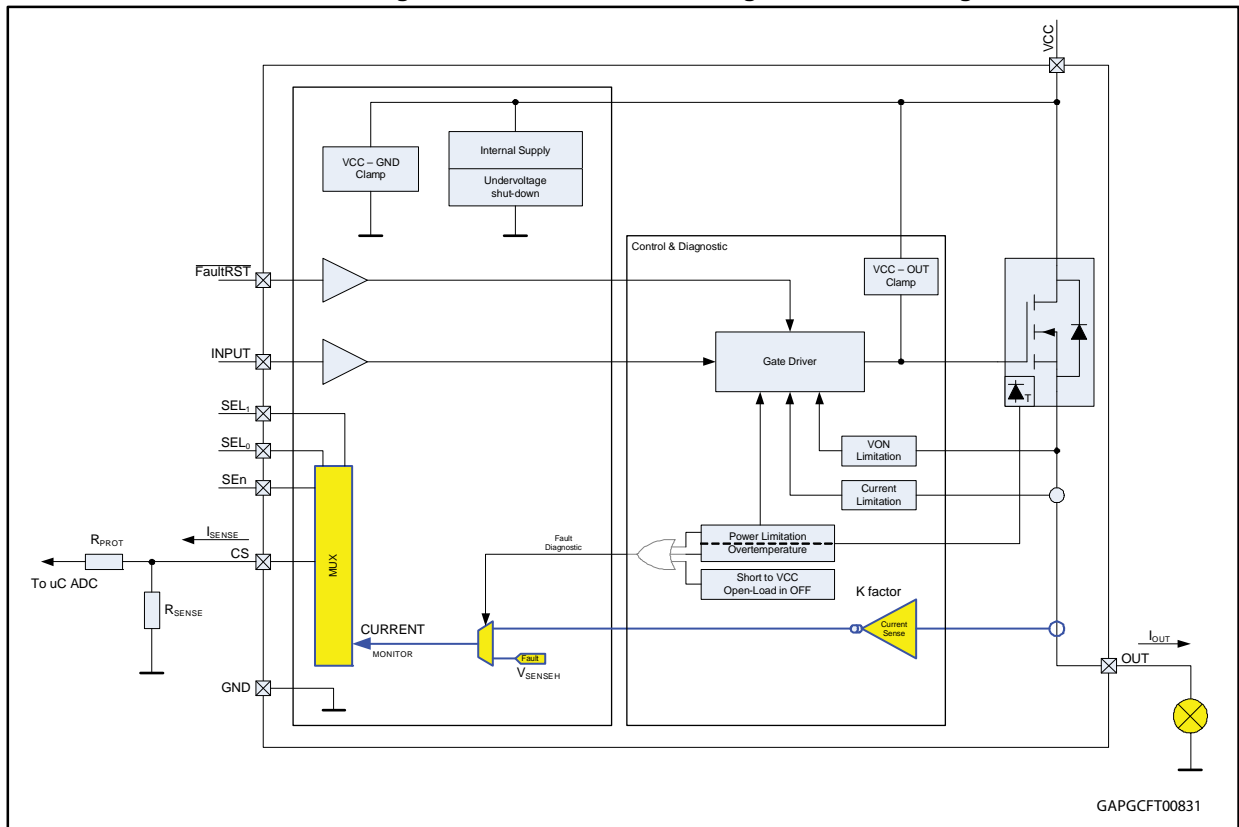
**4.4 CS - analog current sense**

Diagnostic information on device and load status are provided by an analog output pin (CS) delivering the following signals:

- Current monitor: current mirror of channel output current

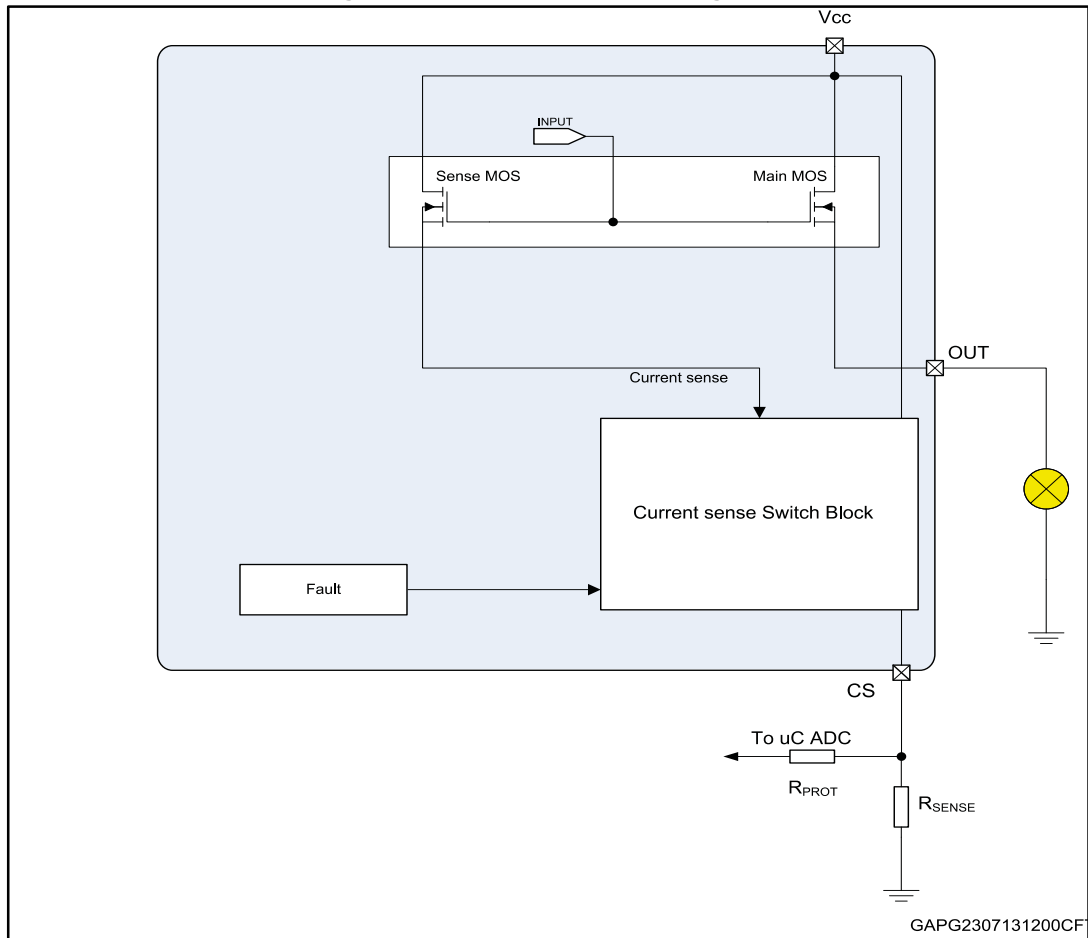
Those signals are routed through an analog multiplexer which is configured and controlled by means of SELx and SEn pins, according to the address map in *MultiSense multiplexer addressing Table*.

**Figure 34: CurrentSense and diagnostic – block diagram**



4.4.1 Principle of CurrentSense signal generation

Figure 35: CurrentSense block diagram



**Current sense**

This current mode is selected in the MultiSense, this output is capable to provide:

- Current mirror proportional to the load current in normal operation, delivering current proportional to the load according to known ratio named **K**
- Diagnostics flag in fault conditions delivering fixed voltage  $V_{SENSEH}$

The current delivered by the current sense circuit,  $I_{SENSE}$ , can be easily converted to a voltage  $V_{SENSE}$  by using an external sense resistor,  $R_{SENSE}$ , allowing continuous load monitoring and abnormal condition detection.

**Normal operation (channel ON, no fault, SEn active)**

While device is operating in normal conditions (no fault intervention),  $V_{SENSE}$  calculation can be done using simple equations

Current provided by CS output:  $I_{SENSE} = I_{OUT}/K$

Voltage on  $R_{SENSE}$ :  $V_{SENSE} = R_{SENSE} \cdot I_{SENSE} = R_{SENSE} \cdot I_{OUT}/K$

Where:

- $V_{SENSE}$  is voltage measurable on  $R_{SENSE}$  resistor
- $I_{SENSE}$  is current provided from CS pin in current output mode

- $I_{OUT}$  is current flowing through output
- K factor represents the ratio between PowerMOS cells and SenseMOS cells; its spread includes geometric factor spread, current sense amplifier offset and process parameters spread of the overall circuitry the specifying ratio between  $I_{OUT}$  and  $I_{SENSE}$ .

**Failure flag indication**

In case of power limitation/overtemperature, the fault is indicated by the CS pin which is switched to a “current limited” voltage source,  $V_{SENSEH}$ .

In any case, the current sourced by the CS in this condition is limited to  $I_{SENSEH}$ .

The typical behavior in case of overload or hard short circuit is shown in *Waveforms section*.

**Figure 36: Analogue HSD – open-load detection in off-state**

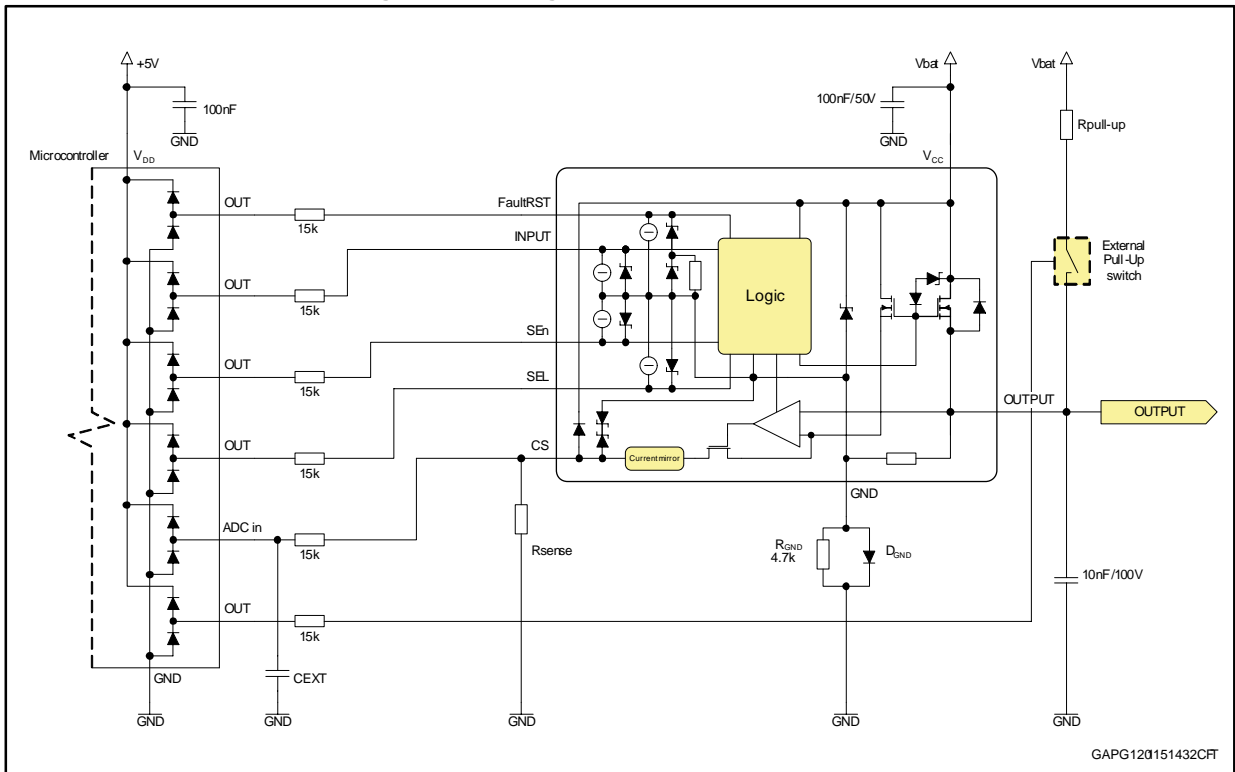
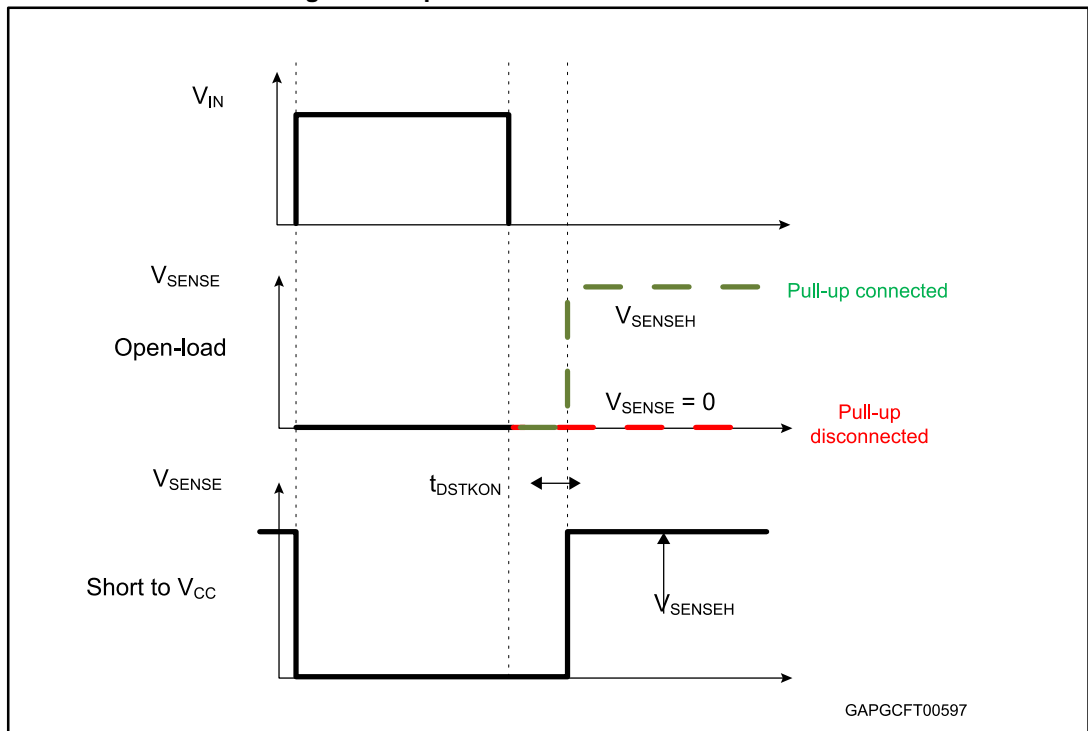


Figure 37: Open-load / short to VCC condition



GAPGFT00597

Table 13: CurrentSense pin levels in off-state

Condition	Output	CS	SEn
Open-load	$V_{OUT} > V_{OL}$	Hi-Z	L
	$V_{OUT} < V_{OL}$	$V_{SENSEH}$	H
Short to $V_{CC}$	$V_{OUT} > V_{OL}$	Hi-Z	L
	$V_{OUT} < V_{OL}$	0	H
Nominal	$V_{OUT} > V_{OL}$	Hi-Z	L
	$V_{OUT} < V_{OL}$	0	H

#### 4.4.2 Short to VCC and OFF-state open-load detection

##### Short to $V_{CC}$

A short circuit between  $V_{CC}$  and output is indicated by the relevant current sense pin set to  $V_{SENSEH}$  during the device off-state. Small or no current is delivered by the current sense during the on-state depending on the nature of the short circuit.

##### OFF-state open-load with external circuitry

Detection of an open-load in off mode requires an external pull-up resistor  $R_{PU}$  connecting the output to a positive supply voltage  $V_{PU}$ .

It is preferable  $V_{PU}$  to be switched off during the module standby mode in order to avoid the overall standby current consumption to increase in normal conditions, i.e. when load is connected.

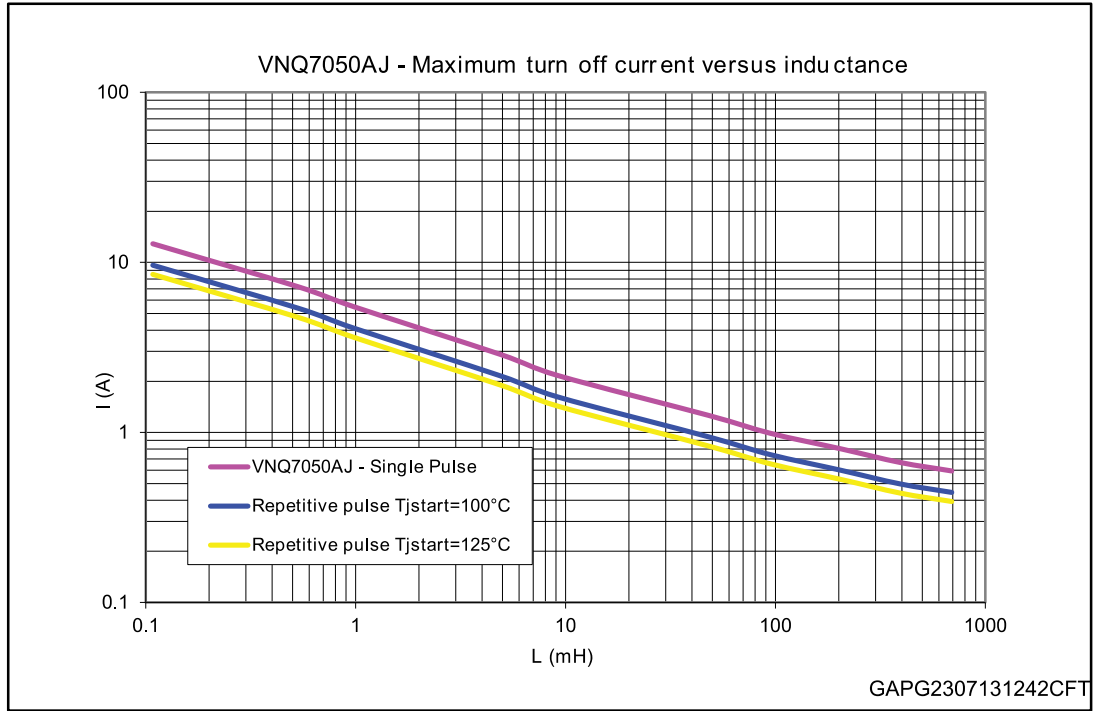
$R_{PU}$  must be selected in order to ensure  $V_{OUT} > V_{OLmax}$  in accordance with the following equation:

**Equation**

$$R_{PU} < \frac{V_{PU} - 4}{I_{L(off2)min @ 4V}}$$

## 5 Maximum demagnetization energy (VCC = 16 V)

Figure 38: Maximum turn off current versus inductance



Values are generated with  $R_L = 0 \Omega$ .

In case of repetitive pulses,  $T_{jstart}$  (at beginning of each demagnetization) of every pulse must not exceed the temperature specified above for curves A and B.

## 6 Package and PCB thermal data

### 6.1 PowerSSO-16 thermal data

Figure 39: PowerSSO-16 on two-layers PCB (2s0p to JEDEC JESD 51-5)

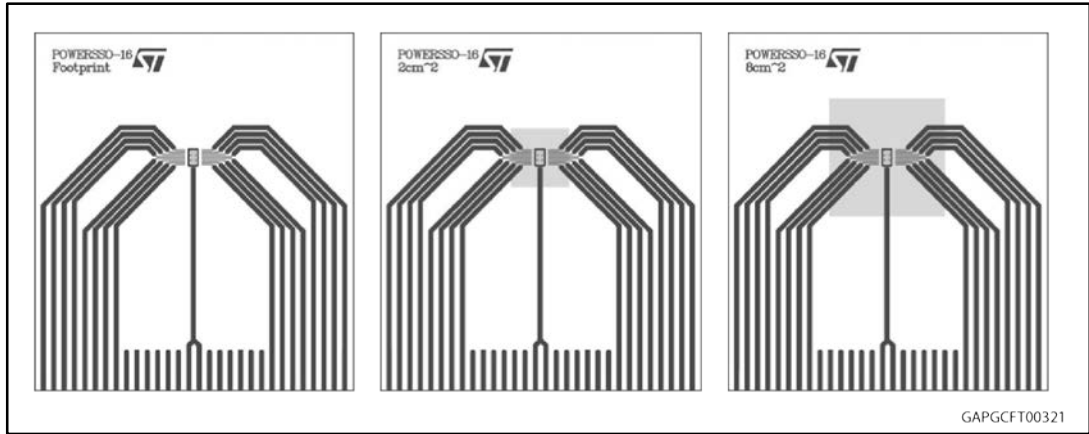


Figure 40: PowerSSO-16 on four-layers PCB (2s2p to JEDEC JESD 51-7)

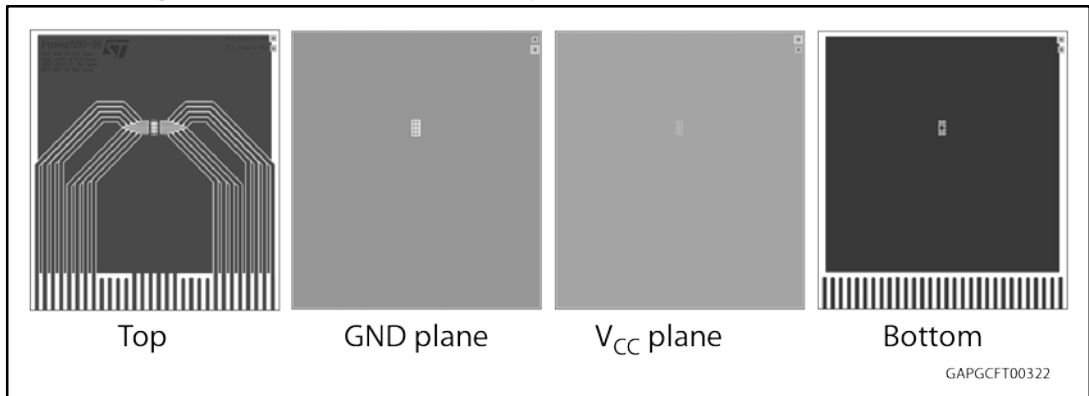


Table 14: PCB properties

Dimension	Value
Board finish thickness	1.6 mm +/- 10%
Board dimension	77 mm x 86 mm
Board Material	FR4
Copper thickness (top and bottom layers)	0.070 mm
Copper thickness (inner layers)	0.035 mm
Thermal vias separation	1.2 mm
Thermal via diameter	0.3 mm +/- 0.08 mm
Copper thickness on vias	0.025 mm
Footprint dimension (top layer)	2.2 mm x 3.9 mm
Heatsink copper area dimension (bottom layer)	Footprint, 2 cm <sup>2</sup> or 8 cm <sup>2</sup>



Figure 41: Rthj-amb vs PCB copper area in open box free air condition (one channel on)

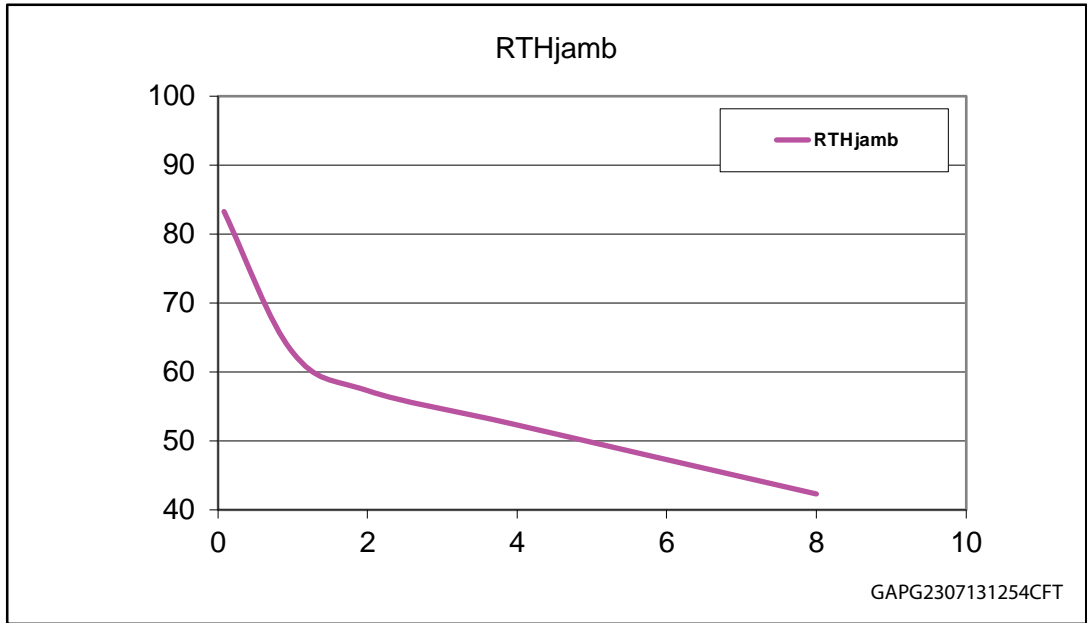
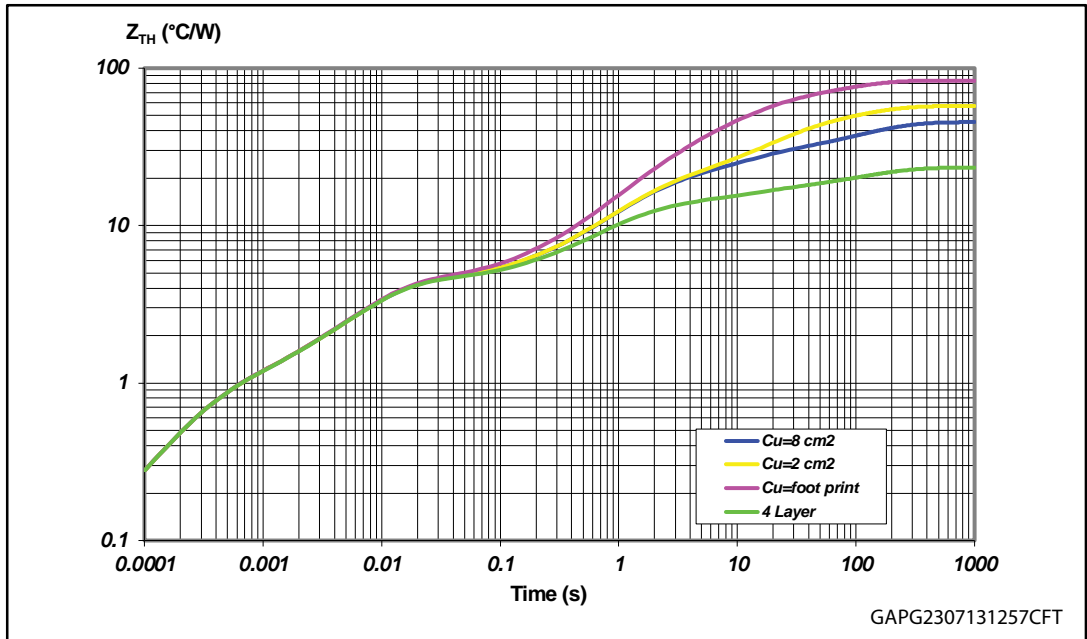


Figure 42: PowerSSO-16 thermal impedance junction ambient single pulse (one channel on)

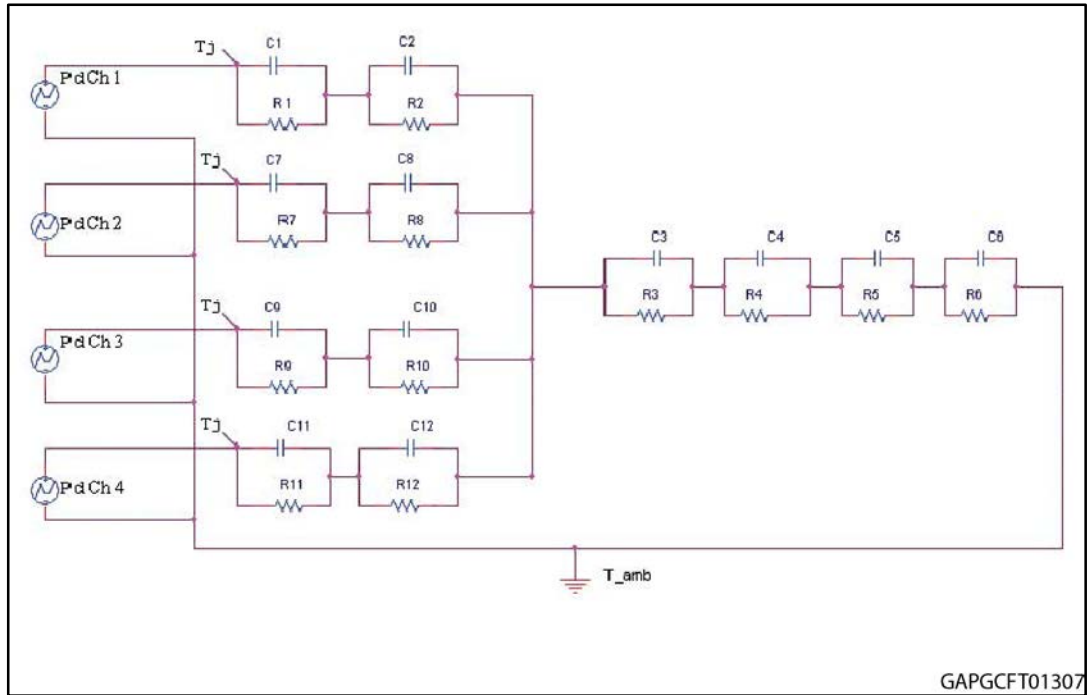


**Equation: pulse calculation formula**

$$Z_{TH\delta} = R_{TH} \cdot \delta + Z_{THtp} (1 - \delta)$$

where  $\delta = t_p/T$

Figure 43: Thermal fitting model of a double-channel HSD in PowerSSO-16



The fitting model is a simplified thermal tool and is valid for transient evolutions where the embedded protections (power limitation or thermal cycling during thermal shutdown) are not triggered.

Table 15: Thermal parameters

Area/island (cm <sup>2</sup> )	Footprint	2	8	
R1 = R7 = R9 = R11 (°C/W)	0.8			
R2 = R8 = R10 = R12 (°C/W)	3.5			
R3 (°C/W)	7	7	7	7
R4 (°C/W)	16	6	6	4
R5 (°C/W)	30	20	10	3
R6 (°C/W)	26	20	18	7
C1 = C7 = C9 = C11 (W.s/°C)	0.00035			
C2 = C8 = C10 = C12 (W.s/°C)	0.0023			
C3 (W.s/°C)	0.14			
C4 (W.s/°C)	0.2	0.3	0.3	0.4
C5 (W.s/°C)	0.4	1	1	4
C6 (W.s/°C)	3	5	7	18

# 7 Package information

In order to meet environmental requirements, ST offers these devices in different grades of ECOPACK® packages, depending on their level of environmental compliance. ECOPACK® specifications, grade definitions and product status are available at: [www.st.com](http://www.st.com). ECOPACK® is an ST trademark.

## 7.1 PowerSSO-16 package information

Figure 44: PowerSSO-16 package dimensions

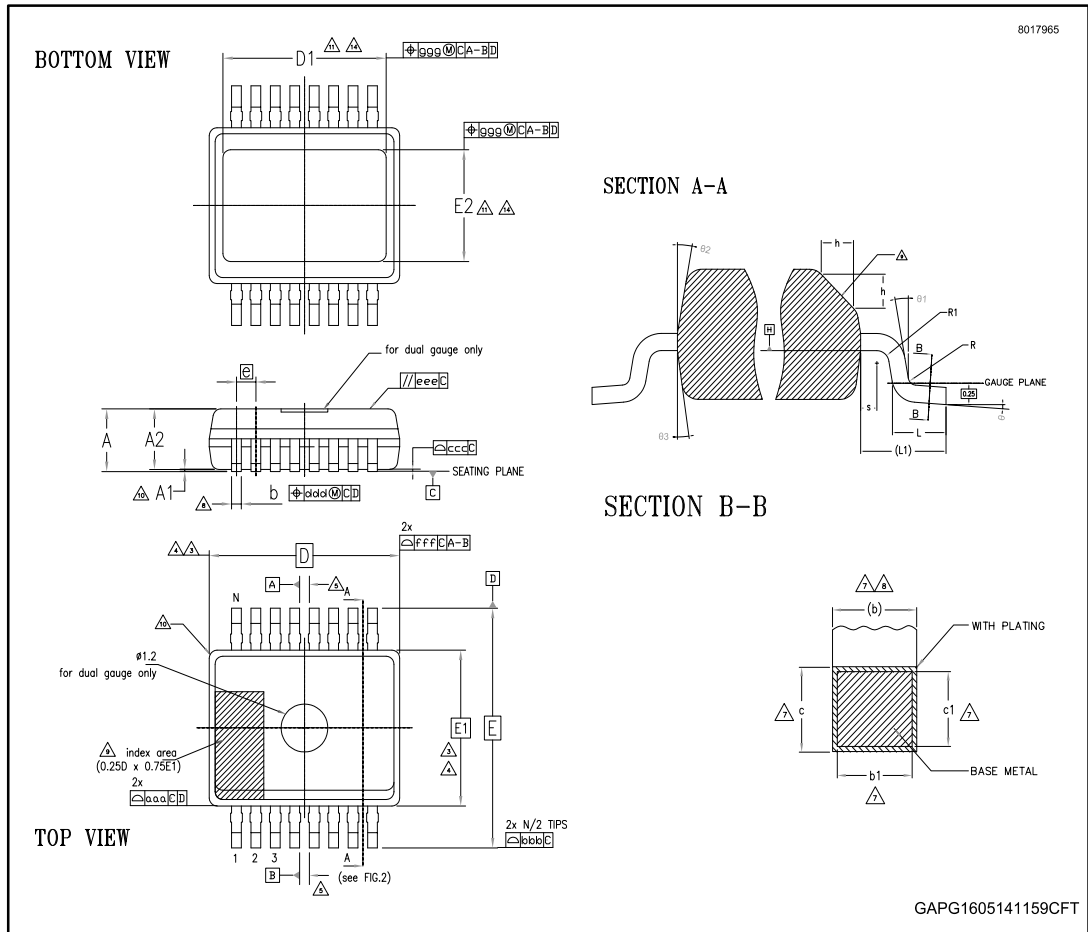


Table 16: PowerSSO-16 mechanical data

Symbol	Millimeters		
	Min.	Typ.	Max.
Θ	0°		8°
Θ1	0°		
Θ2	5°		15°
Θ3	5°		15°
A			1.70
A1	0.00		0.10
A2	1.10		1.60

Symbol	Millimeters		
	Min.	Typ.	Max.
b	0.20		0.30
b1	0.20	0.25	0.28
c	0.19		0.25
c1	0.19	0.20	0.23
D	4.9 BSC		
D1	3.60		4.20
e	0.50 BSC		
E	6.00 BSC		
E1	3.90 BSC		
E2	1.90		2.50
h	0.25		0.50
L	0.40	0.60	0.85
L1	1.00 REF		
N	16		
R	0.07		
R1	0.07		
S	0.20		
<b>Tolerance of form and position</b>			
aaa	0.10		
bbb	0.10		
ccc	0.08		
ddd	0.08		
eee	0.10		
fff	0.10		
ggg	0.15		

## 7.2 PowerSSO-16 packing information

Figure 45: PowerSSO-16 reel 13"

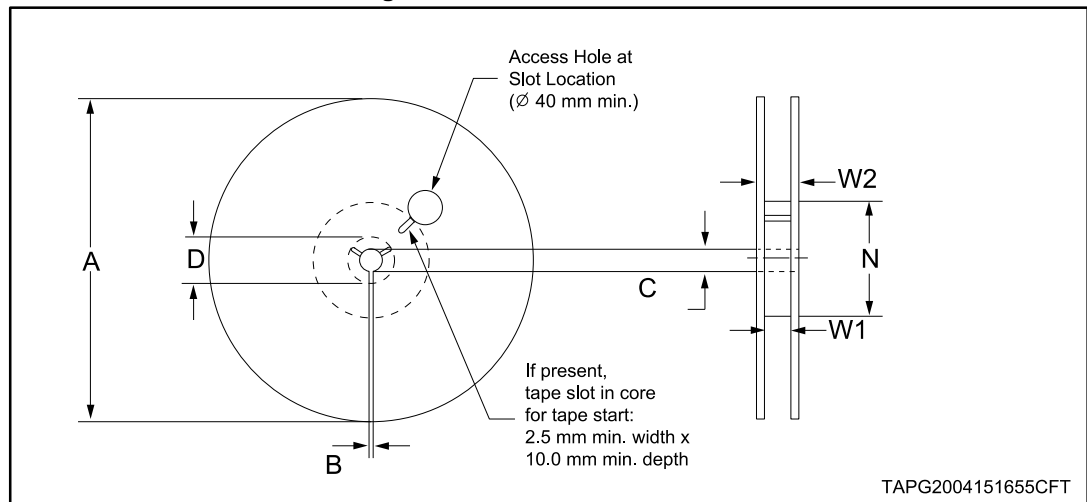


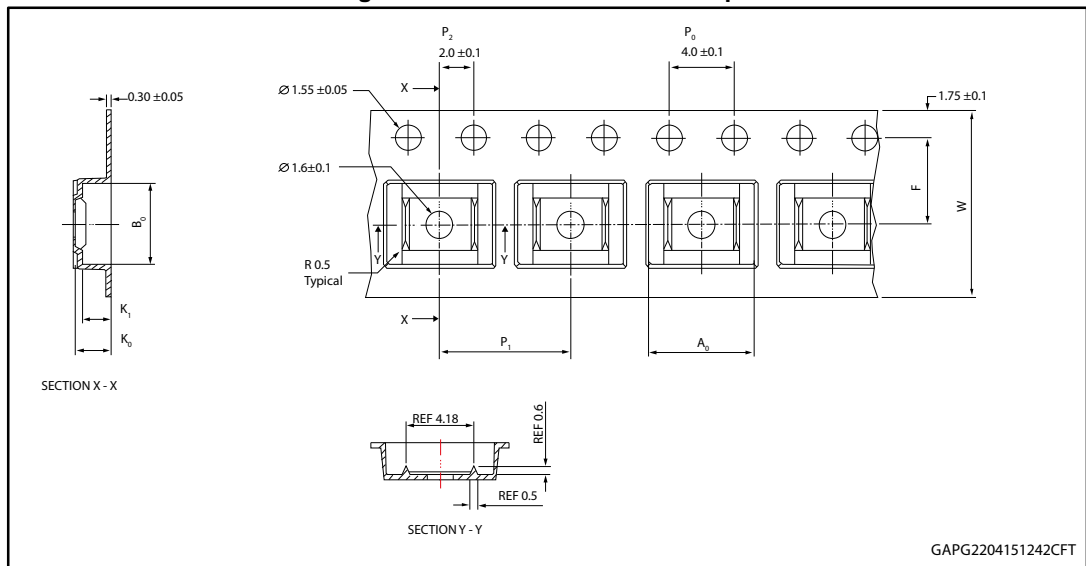
Table 17: Reel dimensions

Description	Value <sup>(1)</sup>
Base quantity	2500
Bulk quantity	2500
A (max)	330
B (min)	1.5
C (+0.5, -0.2)	13
D (min)	20.2
N	100
W1 (+2 /-0)	12.4
W2 (max)	18.4

**Notes:**

<sup>(1)</sup>All dimensions are in mm.

Figure 46: PowerSSO-16 carrier tape



GAPG2204151242CFT

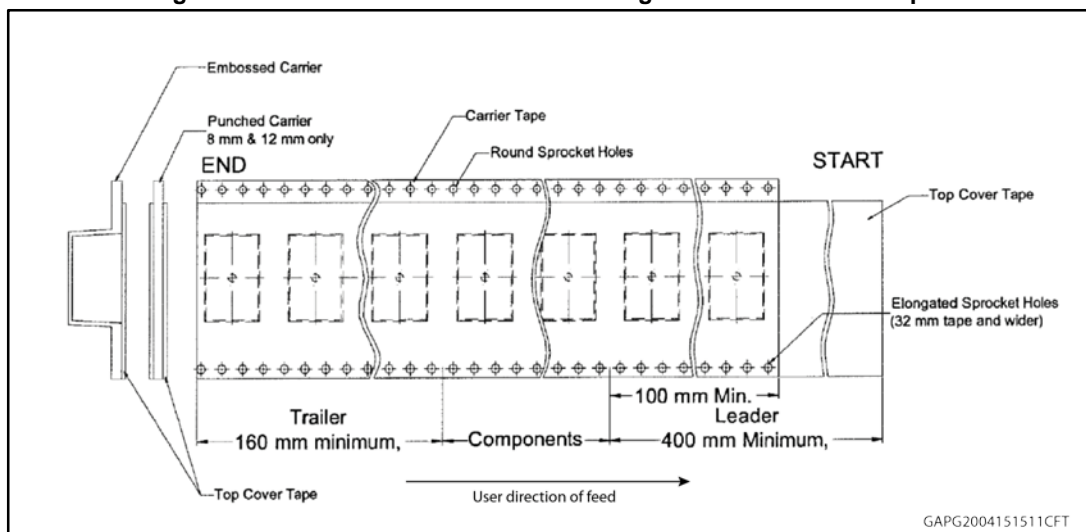
Table 18: PowerSSO-16 carrier tape dimensions

Description	Value <sup>(1)</sup>
A <sub>0</sub>	6.50 ± 0.1
B <sub>0</sub>	5.25 ± 0.1
K <sub>0</sub>	2.10 ± 0.1
K <sub>1</sub>	1.80 ± 0.1
F	5.50 ± 0.1
P <sub>1</sub>	8.00 ± 0.1
W	12.00 ± 0.3

Notes:

<sup>(1)</sup>All dimensions are in mm.

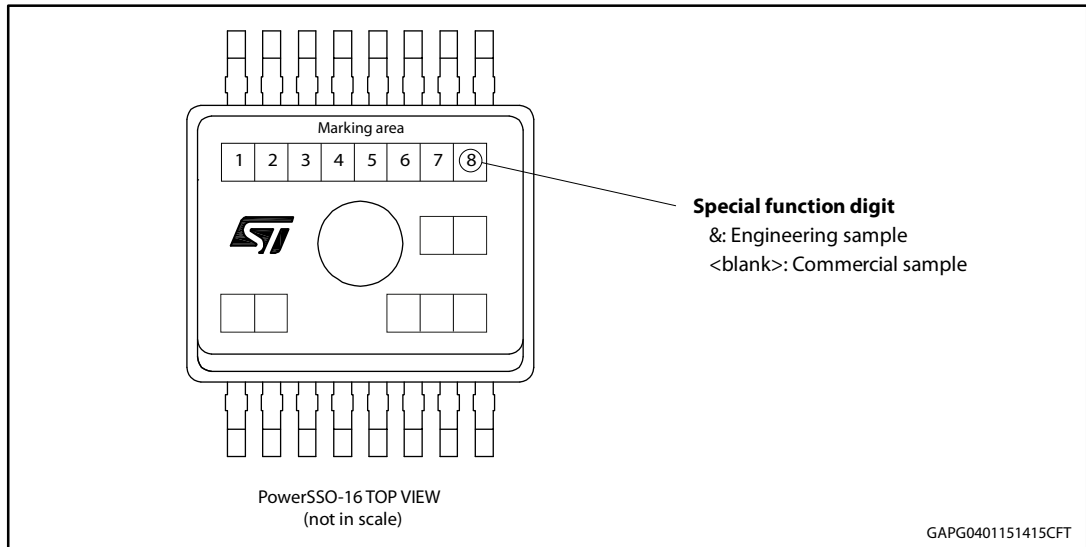
Figure 47: PowerSSO-16 schematic drawing of leader and trailer tape



GAPG2004151511CFT

### 7.3 PowerSSO-16 marking information

Figure 48: PowerSSO-16 marking information



**Engineering Samples:** these samples can be clearly identified by a dedicated special symbol in the marking of each unit. These samples are intended to be used for electrical compatibility evaluation only; usage for any other purpose may be agreed only upon written authorization by ST. ST is not liable for any customer usage in production and/or in reliability qualification trials.

**Commercial Samples:** fully qualified parts from ST standard production with no usage restrictions.

## 8 Order codes

Table 19: Device summary

Package	Order codes
	Tape and reel
PowerSSO-16	VNQ7050AJTR



## 9 Revision history

Table 20: Document revision history

Date	Revision	Changes
04-Jun-2015	1	Initial release.

**IMPORTANT NOTICE – PLEASE READ CAREFULLY**

STMicroelectronics NV and its subsidiaries ("ST") reserve the right to make changes, corrections, enhancements, modifications, and improvements to ST products and/or to this document at any time without notice. Purchasers should obtain the latest relevant information on ST products before placing orders. ST products are sold pursuant to ST's terms and conditions of sale in place at the time of order acknowledgement.

Purchasers are solely responsible for the choice, selection, and use of ST products and ST assumes no liability for application assistance or the design of Purchasers' products.

No license, express or implied, to any intellectual property right is granted by ST herein.

Resale of ST products with provisions different from the information set forth herein shall void any warranty granted by ST for such product.

ST and the ST logo are trademarks of ST. All other product or service names are the property of their respective owners.

Information in this document supersedes and replaces information previously supplied in any prior versions of this document.

© 2015 STMicroelectronics – All rights reserved