

PART NUMBER
10138462-101LF

SL NO.	DESCRIPTION	MATERIAL	PLATING
1	SCREWABLE RECEPTACLE BODY	ALUMINIUM	PASSIVATION
2	PANEL SEALING GASKET	SILICONE	-

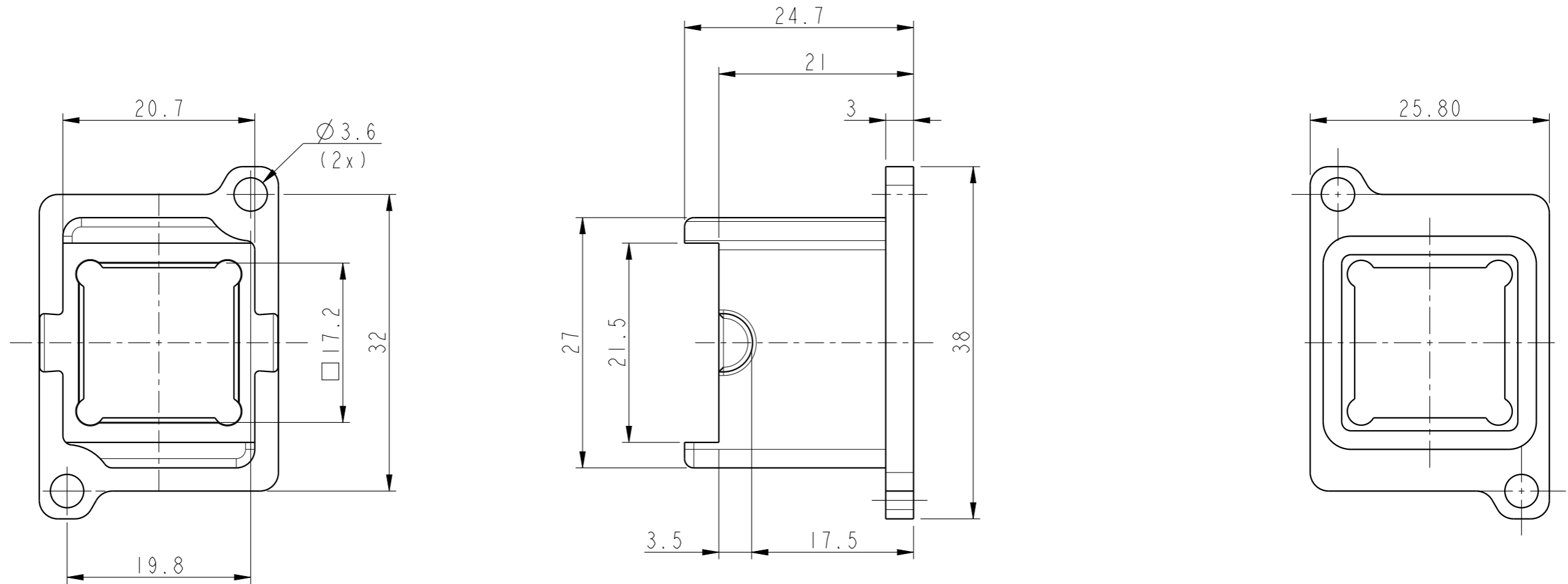

PACKING CONFIGURATION
(ASSEMBLED FORM)

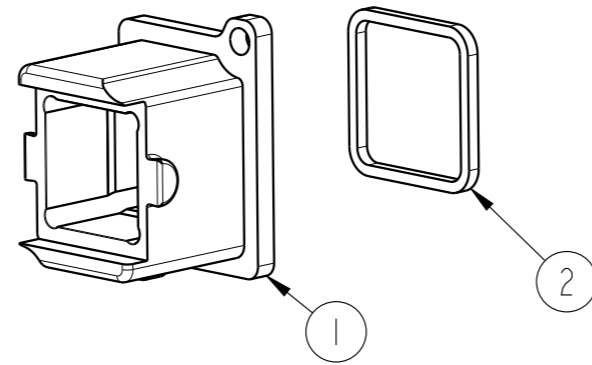
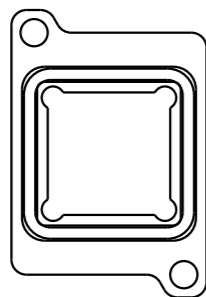

NOTES :-

- PART WILL BE SUPPLIED ONLY IN ASSEMBLED FORM
- SCREWS TO BE USED ARE M3 X 6MM; MATERIAL-STAINLESS STEEL
- CASTED MOUNTING PANEL SHOULD HAVE ON ITS REAR SIDE AN INTEGRAL RECTANGULAR REINFORCED RIBS OF 3MM THICKNESS AND 4MM WIDTH ALONG THE MOUNTING SCREW PLANE AT THE TOP AND BOTTOM TO ACCOMODATE THE BLIND INTERNAL SCREW THREAD

spec ref	dr	Jibin John	2016/11/08	projection	MM	size	A3	scale	1:1
tolerance std	eng	Varghese, Bone	2018/09/08			ecn no	ELX-I-30701-1	rel level	Released
ISO 406 ISO 1101	chr	-	-						
surface	linear	0.X	±0.3	Amphenol FCI	BULKHEAD (RECEPTACLE) - UNIVERSAL OCTIS, 26MM PITCH	dwg no	10138462	rev	C
		0.XX	±0.1						
0.XXX	±0.05								
ISO 1302	angular	0°	±2°	cat. no.	-	Product - Customer Drw	sheet 1 of 1		