

ATLANTIC VERSION TERMINATOR INTERFACE ADAPTER	PART NUMBER	REVISION	DESCRIPTION	FEED TYPE	CONVERT TO	PART NUMBERS REQUIRED					
	2151345-1	B	FINE CRIMP HEIGHT ADJUST	MECHANICAL	PNEUMATIC FEED	2119950-1	1338685-1	5-18022-5	2119641-1	2119799-1	2063440-1
	2151345-2	B	FINE CRIMP HEIGHT ADJUST	PNEUMATIC	SERVO LATCH PLATE	2119951-1	-	8-2151345-5	1901094-3	-	2168400-6 (QUANTITY 2)
					SMART APPLICATOR	2161326-1	-	8-2151345-4	-	-	
					MECHANICAL FEED	2119949-1	1338685-1	5-18022-5	2119653-1	-	-
	2151345-5	B	FINE CRIMP HEIGHT ADJUST	SERVO LATCH PLATE	SERVO LATCH PLATE	2119951-1	-	8-2151345-5	1901094-3	-	2168400-6 (QUANTITY 2)
					SMART APPLICATOR	2161326-1	-	8-2151345-4	-	-	
					MECHANICAL FEED	2119949-1	1338685-1	5-18022-5	2119653-1	-	-
2151345-6	B	NON-CRIMP HEIGHT ADJUST	SERVO LATCH PLATE	-	-	-	-	-	-	-	
2151345-7	B	FINE CRIMP HEIGHT ADJUST	NONE	-	-	-	-	-	-	-	
7-2151345-7	A	CRIMP TOOLING KIT	-	-	-	-	-	-	-	-	

APPLICATOR DATA		
CRIMP WIRE	SIZE	TYPE
WIRE	2.54 mm [.100]	F
INSUL	4.30 mm [.170]	O
APPLICATOR INSTRUCTIONS 408-10389		

TERMINAL DATA: TE TERMINAL		TE CRIMP SPECIFICATION	
TERMINAL NAME: 1.50mm CONTACT SOCKET			
WIRE STRIP LENGTH		INSULATION DIAMETER RANGE	
5.20-5.80 mm [.205-.228 IN]		Ø2.20-3.00 mm [.087-.118 IN]	
TERMINAL APPLICATION SPECIFICATION	(A)114-18020	-	-
	(B)114-18040	-	-
TERMINALS APPLIED			
TE TERMINAL	TE TERMINAL	TE SEAL	TE SEAL
(A) 929968-1	(B) 929990-1	(A) 828921-1	
(A) 929968-7	(B) 929990-3	(A) 828921-2	
(A) 929975-1	(B) 929990-4	(B) 828904-1	
(A) 929975-4	(B) 929990-7	(B) 828904-2	
(A) 929975-7	(B) 1-929990-0	(B) 828904-3	
(A) 929975-8	(B) 1703014-1	(B) 828905-1	
(B) 1703050-1	(B) 1703014-4		
(B) 1-1719188-0			

WIRE SIZE	CRIMP HEIGHT mm [INCH]	CRIMP HEIGHT REFERENCE SETTING
2.50mm2	1.97+/-0.03 [.078+/-0.001]	5.1
2.00mm2	1.82+/-0.03 [.072+/-0.001]	6.8
1.50mm2	1.67+/-0.03 [.066+/-0.001]	8.5
16 AWG	1.58+/-0.03 [.062+/-0.001]	9.6

- 1 RECOMMENDED SPARE PARTS
- 2 GREASE BEARING SURFACES LIGHTLY
- 3 LUBRICATE DAILY PER THE APPLICATOR INSTRUCTION SHEET SUPPLIED WITH THE APPLICATOR.
- 4 APPLICATOR SPECIFIC DATA TO BE ENTERED INTO BLANK MEMORY CHIP AT ASSEMBLY. SEE BELOW FOR PART NUMBER:  
 MECHANICAL FEED WITH "SMART APPLICATOR" CONVERSION: 8-2151345-4  
 PNEUMATIC FEED WITH "SMART APPLICATOR" CONVERSION: 8-2151345-4  
 SERVO FEED WITH "FINE CRIMP HEIGHT ADJUST": 8-2151345-5  
 SERVO FEED WITH "NON-CRIMP HEIGHT ADJUST": 8-2151345-6
- 5 ADJUSTMENT OF THE STRIPPER MAY BE REQUIRED WHEN MOVING THE APPLICATOR BETWEEN BENCH AND LEADMAKER APPLICATIONS.
- 6 APPLY PART NUMBER 1-23419-5 LOCTITE TO THREADS OF ITEM 50.
- 7 GREASE THREADS, GROOVE AND O-RING ON ITEMS 35 & 252.
- 8 MAGNET, ITEM 166 MUST BE ORIENTED CORRECTLY IN ORDER TO PROPERLY ACTUATE THE COUNTER.
- 9 CRIMP HEIGHT REFERENCE SETTING WAS THE SETTING USED WHEN THE APPLICATOR WAS QUALIFIED AT THE FACTORY. ADJUSTMENT MAY BE NECESSARY WHEN RUNNING APPLICATOR IN THE FIELD.
- 10 SPARE FEED CAM STORAGE LOCATION REFER TO INSTRUCTION SHEET FOR ADDITIONAL INFORMATION.
- 11 TO CONVERT THE APPLICATOR TO A NON-CARRIER CUTTING STYLE, REMOVE ITEM 13 AND ATTACH TO THE LOCATION ON THE BACK SIDE OF THE HOUSING. REFER TO INSTRUCTION SHEET FOR ADDITIONAL INFORMATION.
- 12 WHEN ASSEMBLING -6 NON-CRIMP HEIGHT ADJUST APPLICATOR USE SHIM PACK 2119957-2 TO ALIGN APPLICATOR'S MAXIMUM WIRE CRIMP HEIGHT AT NORMAL TERMINATOR SHUT HEIGHT
- 13 INSULATION RANGE QUOTED IS THAT OF THE TERMINAL.  
 SEAL PN 828905 - INS. DIA RANGE IS Ø2.2-3.0mm  
 SEAL PN 828904 - INS. DIA RANGE IS Ø1.2-2.1mm  
 SEAL PN 828921 - INS. DIA RANGE IS Ø2.1-3.0mm
- 14 APPLY TORQ-SEAL IN ALLEN SOCKET TO FILL HOLE AFTER FLAT HD HAS BEEN ADJUSTED TO CORRECT HEIGHT AT QUALIFICATION. APPLY #1-23419-5 LOC-TITE TO THREADS.

**\*WARNING**  
 ON INSTALLATION, SET WIRE DISC, ITEM 40 TO LARGEST WIRE SIZE SETTING. USE OF SETTINGS BELOW MINIMUM REQUIRED CRIMP HEIGHT SETTING WILL CAUSE DAMAGE TO CRIMP TOOLING.

-77	-7	-6	-5	-2	-1	PART NO	DESCRIPTION	ITEM NO
-	-	1	-	-	-	2119957-2	APPLICATOR SHIM PACK	260
-	1	-	1	1	1	8-21084-0	O-RING, .676 ID, .070 DIA. MAT.	252
-	-	-	-	1	-	2119640-1	PUSH ROD, AIR FEED	250
-	-	-	-	1	-	2079988-1	BUSHING, LCH5-12, MISUMI	249
-	-	-	-	1	-	2119641-1	FEED CAM, AIR FEED	248
-	1	-	1	1	1	2119798-1	DETENT PIN	247
-	1	-	1	1	1	1-22279-3	SPRING, COMPRESSION	246
-	-	1	-	-	-	2119758-1	RAM, AMP STYLE, SIDE FEED, NON-ADJ.	245

**ATLANTIC VERSION**  
 Shown on sheets 1 of 4 & 2 of 4  
 (Pacific version shown on sheets 3 of 4 & 4 of 4)

SET UP GAUGE	LOC	DIST	REVISIONS					
2119599-1	A	66	P	LTN	DESCRIPTION	DATE	OWN	APVD
			A		RELEASED	04MAY2012	YY	SX
			B		ECR-13-018490	18NOV2013	KH	TE

-	1	1	1	1	1	2119082-9	CAM, SNAIL, INSULATION ADJUSTMENT	244
-	1	1	1	1	1	2079764-1	WASHER, WAVE SPRING, CREST-TO-CREST	243
-	1	1	1	1	1	2119083-1	RETAINER, INSULATION DIAL	242
-	1	1	1	1	1	7-18023-7	SCR, SKT HD CAP M3 X 4.0	241
-	-	2	2	-	-	2168400-6	SHCS, LOW HEAD, RoHS, M5 X 16	240
-	-	-	-	-	1	2119580-1	MECHANICAL FEED ASSEMBLY	239
-	-	-	-	-	1	2063440-1	AIR FEED MODULE	238
-	-	1	1	-	-	2119740-2	TAG, IDENTIFICATION	213
-	-	1	1	-	-	1901094-3	SPACER, FEEDER	198
-	1	1	1	1	1	1976053-2	LOCATER BLOCK, TERMINAL	179
-	1	1	1	1	1	993111-1	PIN, SLOTTED SPRING 3.0 X 20.0	177
-	1	1	1	1	1	8-22280-7	SPRING, COMPRESSION	176
-	1	1	1	1	1	1752353-2	GUIDE PIN, HOLDDOWN	175
-	1	1	1	1	1	1901680-2	GUIDE PIN, HOLDDOWN	174
-	-	-	-	2	-	21045-3	RING, RETAIN, EXTERN, 3/16 CRESCENT	172
-	1	1	1	1	1	994969-1	MAGNET, RARE EARTH HIGH ENERGY	166
-	REF	REF	REF	REF	REF	994970-2	COUNTER, MAGNETIC	164
-	-	-	-	1	-	240638-1	SPRING, FEED FINGER	163
-	-	-	-	1	-	3-23627-7	PIN, RETAIN, GRVD, 3/16 X .854	137
-	-	-	-	1	-	2119799-1	HOLDER, FEED FINGER, AF	136
-	-	REF	REF	-	-	SEE NOTE 4	MEMORY CHIP, PROGRAMMED	135
-	-	1	1	-	-	1633743-1	SERVO FEED LATCH ASM	133
-	1	1	1	1	1	1-18028-2	WASHER, FLAT, REG M4	119
-	-	REF	REF	-	-	2119944-1	FEED FINGER ASSEMBLY, SF	117
-	1	1	1	1	1	455888-5	SPACER, CRIMPER	82
-	1	1	1	1	1	2119956-1	DOCUMENTATION PACKAGE	71
-	1	-	-	1	1	2119740-1	TAG, IDENTIFICATION	67
-	2	2	2	2	2	2168078-1	SCREW, DRIVE, RH, RoHS, 2 x .188	66
-	2	2	2	2	2	1-2079383-0	SCR, BHSC, RoHS (M3 X 6)	64
-	1	-	1	1	1	2119793-1	LIMITER, ADJUSTMENT BOLT	63
-	3	-	3	3	3	992763-5	SCR, SET, SOC, CONE POINT, M3 X 4.0	62
-	1	1	1	1	1	2079383-4	SCR, BHSC, RoHS (M4 X 8)	60
-	-	-	-	1	1	5-18022-5	SCR, HEX HD CAP, M4 X 6.0	59
-	1	1	1	1	1	985575-3	SCR, FLT SKT HD CAP M3 X 10.0	57
-	-	-	-	1	1	1338685-1	PAWL, FEED	56
-	4	4	4	4	4	2168400-1	SHCS, LOW HEAD, RoHS, M4 X 12	54
-	1	1	1	1	1	1-5018030-0	NUT, HEX, REG, RoHS, M3.5	52
-	1	1	1	1	1	1901681-8	HOLDDOWN, TERMINAL	51
-	1	1	1	1	1	2-1752354-2	STANDOFF, HOLD-DOWN	50
-	-	-	-	1	2	18023-9	SCR, SKT HD CAP M4 X 6.0	49
-	-	-	-	-	1	2119652-1	FEED CAM, PRE FEED	48
-	-	-	-	-	1	2119653-1	FEED CAM, POST FEED	47
-	1	1	1	1	1	2119656-9	APPLICATOR BASIC ASSEMBLY, SF	46
-	1	-	1	1	1	2119370-1	RAM, AMP STYLE, SIDE FEED	44
-	1	1	1	1	1	2079383-7	SCR, BHSC, RoHS (M8 X 25)	41
-	1	-	1	1	1	2119645-1	DISC, NUMBERED FA WIRE ADJUSTMENT	40
-	1	-	1	1	1	2119957-1	APPLICATOR SHIM PACK	39
-	1	1	1	1	1	2119644-2	RAM WASHER, PRECISION	38
-	1	1	1	1	1	2119085-1	FA HEAD, ATLANTIC STYLE	37
-	1	-	1	1	1	2119092-1	BOLT, ADJUSTMENT	35
-	1	1	1	1	1	1-1752356-7	SUPPORT, TERMINAL	34
-	2	2	2	2	2	2079383-5	SCR, BHSC, RoHS (M4 X 20)	33
-	1	1	1	1	1	2161328-1	HEX HEAD, FLANGED, M5 X 8mm LONG	32
-	1	1	1	1	1	1320908-6	SPACER, STRIP GUIDE	30
-	1	1	1	1	1	2119959-1	ASSEMBLY, STRIP GUIDE	29
-	1	1	1	1	1	455888-3	SPACER, CRIMPER	28
-	1	1	1	1	1	1320928-3	STRIP GUIDE	24
-	1	1	1	1	1	2168083-2	SCR, SKT HD CAP, RoHS, M4 X 8.0	21
-	1	1	1	1	1	1-18028-2	WASHER, FLAT, REG M4	20
-	1	1	1	1	1	2119533-1	STRIPPER, SIDE FEED	19
-	1	1	1	1	1	2119806-1	INSERT, SHEAR	13
-	1	1	1	1	1	3-22280-3	SPRING, COMPRESSION	12
-	1	1	1	1	1	1-356885-4	STOP, SHEAR	11
-	1	1	1	1	1	2119805-1	SHEAR HOLDER, FRONT	10
-	1	1	1	1	1	318707-1	FLOATING SHEAR, FRONT	9
-	1	1	1	1	1	1-1333206-6	ANVIL, COMBINATION .100	8
-	-	-	-	-	-	-	-	7
-	-	-	-	-	-	-	-	6
-	1	1	1	1	1	2119781-5	DEPRESSOR, SHEAR	5
-	1	1	1	1	1	2-238011-1	BLOCK, CRIMPER SPACER	4
-	1	1	1	1	1	1633996-8	CRIMPER, INSULATION SPECIAL	3
-	1	1	1	1	1	1-455888-1	SPACER, CRIMPER	2
-	1	1	1	1	1	456407-6	CRIMPER, WIRE PREMIUM	1
-77	-7	-6	-5	-2	-1	PART NO	DESCRIPTION	ITEM NO

DIMENSIONS:		TOLERANCES UNLESS OTHERWISE SPECIFIED:		DRAWING NO		CAGE CODE		DRAWING NO		RESTRICTED TO	
mm	0 PLC ±.05	1 PLC ±.05	2 PLC ±.05	3 PLC ±.05	4 PLC ±.05	5 PLC ±.05	6 PLC ±.05	7 PLC ±.05	8 PLC ±.05	9 PLC ±.05	10 PLC ±.05
	ANGLES ±.0001										
MATERIAL	FINISH	WEIGHT	APVD	DATE	SCALE	SHEET	OF	REV			
			G. BAILEY	09NOV2011	1:2	1	4	B			

LOC		DIST		REVISIONS			
A	66	P	LTM	DESCRIPTION	DATE	OWN	APVD
		-	-	SEE SHEET 1	-	-	-

### FEED TYPE MECHANICAL



### PNEUMATIC

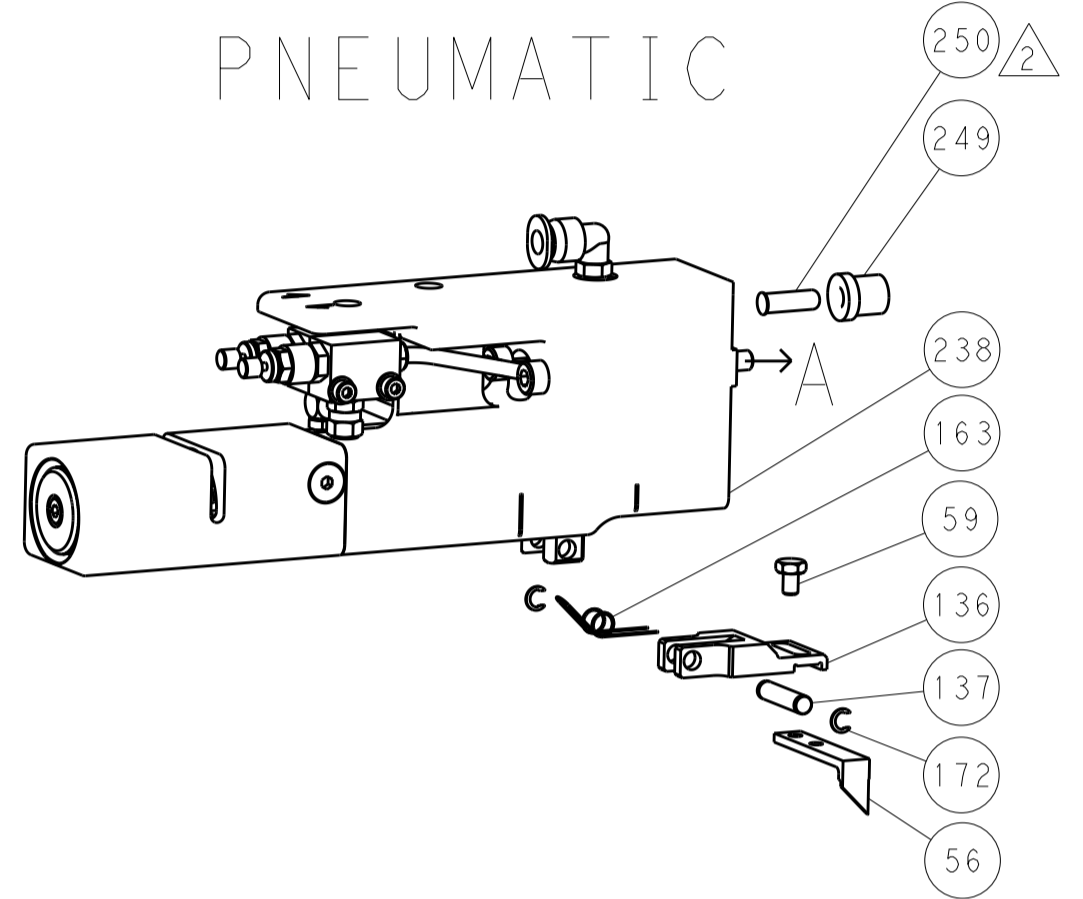

### SERVO LATCH PLATE



### CAM POSITIONS

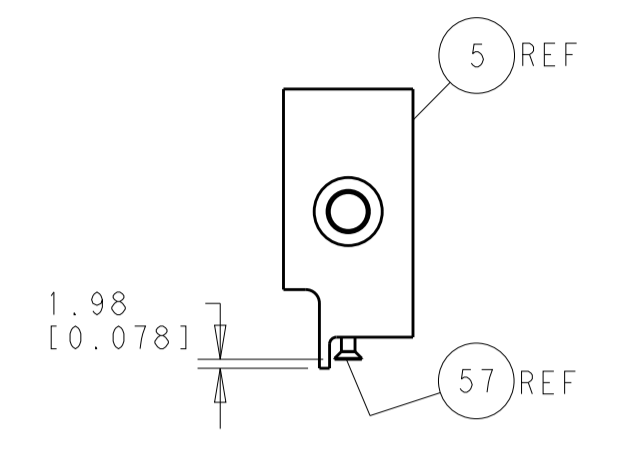
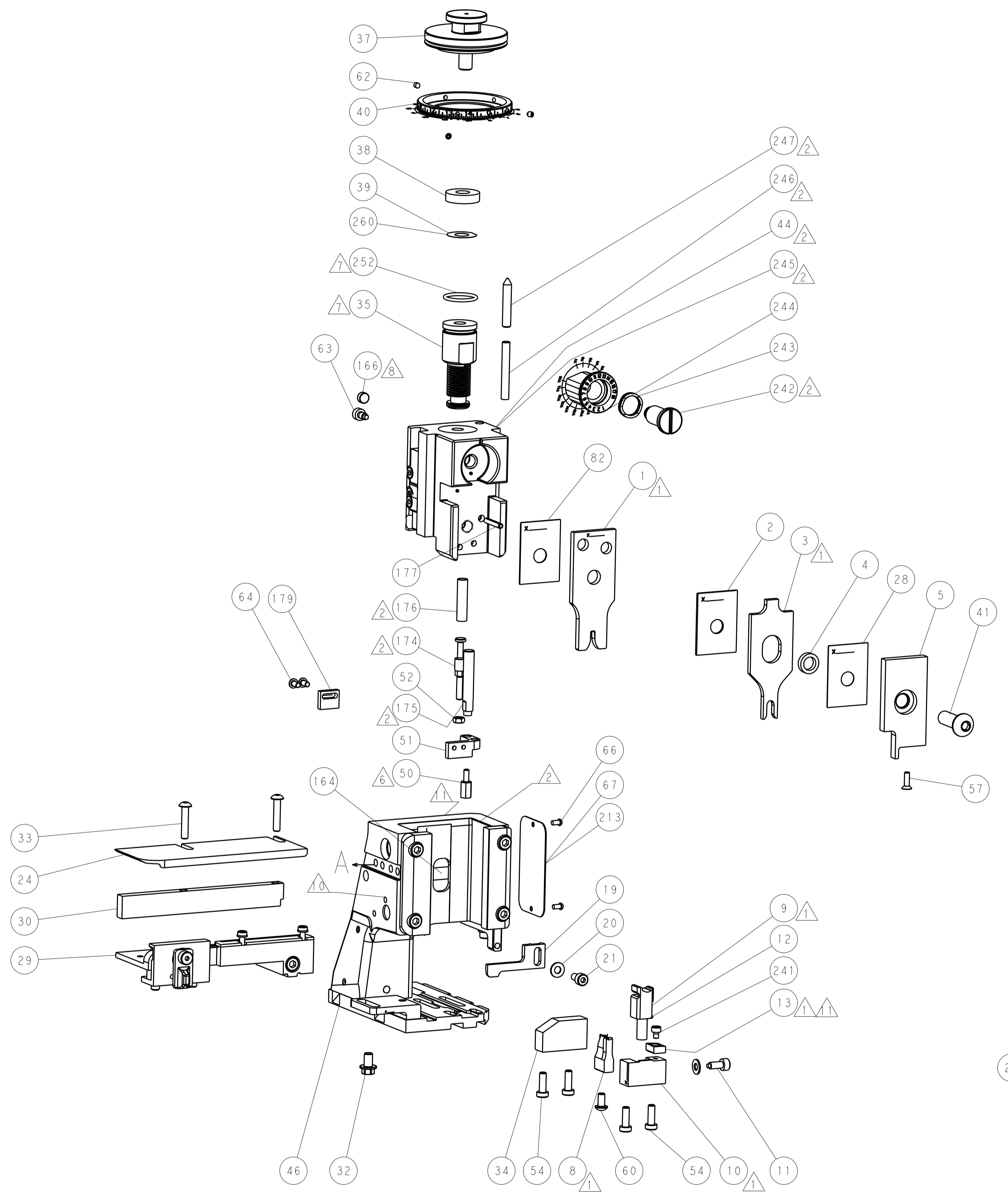

SHEAR DEPRESSOR DETAIL

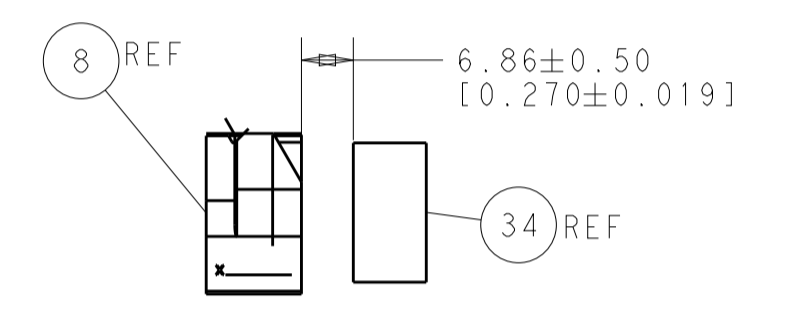

TERMINAL SUPPORT LOCATION

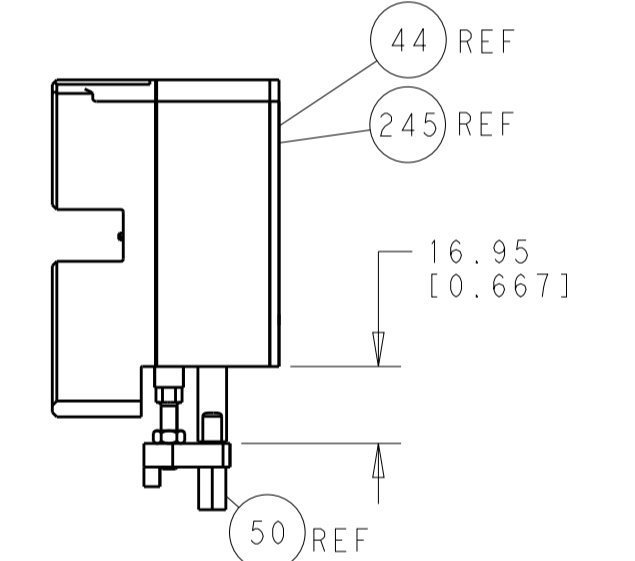

HOLDDOWN SET-UP

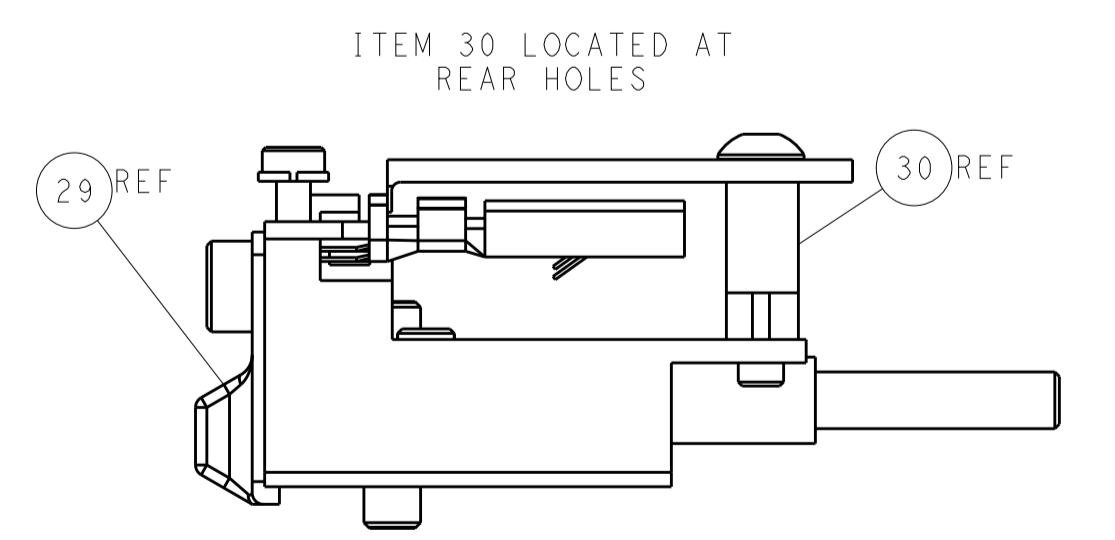

FEED TRACK POSITION GUIDE BY INSULATION BARREL

**ATLANTIC VERSION**  
 Shown on sheets 1 of 4 & 2 of 4  
 (Pacific version shown on sheets 3 of 4 & 4 of 4)

DIMENSIONS:		TOLERANCES UNLESS OTHERWISE SPECIFIED:		DWN Y. YIN 09NOV2011		TE Connectivity	
mm	0 PLC ±0.5	1 PLC ±0.13	2 PLC ±0.013	3 PLC ±0.001	CHK G. BAILEY 09NOV2011	Harrisburg, PA 17105-3608	
MATERIAL:		FINISH:		APVD S. XI 09NOV2011		NAME	
				PRODUCT SPEC		Ocean Side Feed	
				APPLICATION SPEC		Applicator	
				WEIGHT		SIZE CAGE CODE DRAWING NO	
				CUSTOMER ACCESSIBLE PRODUCTION DRAWING		A1 00779 C=2151345	
				SCALE		RESTRICTED TO	
				1:2		SHEET 2 OF 4 REV B	

PACIFIC VERSION TERMINATOR INTERFACE ADAPTER	PART NUMBER	REVISION	DESCRIPTION	FEED TYPE	APPLICATOR STYLE CONVERSION CHART						
					CONVERT TO	PART NUMBERS REQUIRED					
	2-2151345-1	B	FINE CRIMP HEIGHT ADJUST	MECHANICAL	PNEUMATIC FEED	2119950-1	1338685-1	5-18022-5	2119641-2	2119799-1	2063440-1
					SERVO LATCH PLATE	2119951-1	-	8-2151345-5	1901094-3	-	2168400-6 (QUANTITY 2)
					SMART APPLICATOR	2161326-1	-	8-2151345-4	-	-	
	2-2151345-2	B	FINE CRIMP HEIGHT ADJUST	PNEUMATIC	MECHANICAL FEED	2119949-1	1338685-1	5-18022-5	2119653-2	-	-
					SERVO LATCH PLATE	2119951-1	-	8-2151345-5	1901094-3	-	2168400-6 (QUANTITY 2)
					SMART APPLICATOR	2161326-1	-	8-2151345-4	-	-	
	2-2151345-5	B	FINE CRIMP HEIGHT ADJUST	SERVO LATCH PLATE <sup>4</sup>	MECHANICAL FEED	2119949-1	1338685-1	5-18022-5	2119653-2	-	-
					PNEUMATIC FEED	2119950-1	1338685-1	5-18022-5	2119641-2	2119799-1	2063440-1
	2-2151345-7	B	FINE CRIMP HEIGHT ADJUST	NONE	-	-	-	-	-	-	-
	7-2151345-7	A	CRIMP TOOLING KIT	-	-	-	-	-	-	-	-

APPLICATOR DATA		
CRIMP	SIZE	TYPE
WIRE	2.54 mm [.100]	F
INSUL	4.30 mm [.170]	O
APPLICATOR INSTRUCTIONS 408-10389		

TERMINAL DATA: TE TERMINAL		TE CRIMP SPECIFICATION	
TERMINAL NAME: 1.50mm CONTACT SOCKET			
WIRE STRIP LENGTH		INSULATION DIAMETER RANGE	
5.20-5.80 mm [1.205-.228 IN]		Ø2.20-3.00 mm [1.087-.118 IN]	
TERMINAL APPLICATION SPECIFICATION	(A)114-18020	-	-
	(B)114-18040	-	-
TERMINALS APPLIED			
TE TERMINAL	TE TERMINAL	TE SEAL	TE SEAL
(A) 929968-1	(B) 929990-1	(A) 828921-1	
(A) 929968-7	(B) 929990-3	(A) 828921-2	
(A) 929975-1	(B) 929990-4	(B) 828904-1	
(A) 929975-4	(B) 929990-7	(B) 828904-2	
(A) 929975-7	(B) 1-929990-0	(B) 828904-3	
(A) 929975-8	(B) 1703014-1	(B) 828905-1	
(B) 1703050-1	(B) 1703014-4		
(B) 1-1719188-0			

WIRE SIZE	CRIMP HEIGHT mm [INCH]	CRIMP HEIGHT REFERENCE SETTING
2.50mm2	1.97+/-0.03 [1.078+/-0.001]	5.1
2.00mm2	1.82+/-0.03 [1.072+/-0.001]	6.8
1.50mm2	1.67+/-0.03 [1.066+/-0.001]	8.5
16 AWG	1.58+/-0.03 [1.062+/-0.001]	9.6

- 1 RECOMMENDED SPARE PARTS
- 2 GREASE BEARING SURFACES LIGHTLY
- 3 LUBRICATE DAILY PER THE APPLICATOR INSTRUCTION SHEET SUPPLIED WITH THE APPLICATOR.
- 4 APPLICATOR SPECIFIC DATA TO BE ENTERED INTO BLANK MEMORY CHIP AT ASSEMBLY. SEE BELOW FOR PART NUMBER:  
 MECHANICAL FEED WITH "SMART APPLICATOR" CONVERSION: 8-2151345-4  
 PNEUMATIC FEED WITH "SMART APPLICATOR" CONVERSION: 8-2151345-4  
 SERVO FEED WITH "FINE CRIMP HEIGHT ADJUST": 8-2151345-5
- 5 ADJUSTMENT OF THE STRIPPER MAY BE REQUIRED WHEN MOVING THE APPLICATOR BETWEEN BENCH AND LEADMAKER APPLICATIONS.
- 6 APPLY PART NUMBER 1-23419-5 LOCTITE TO THREADS OF ITEM 50.
- 7 GREASE THREADS, GROOVE AND O-RING ON ITEMS 139 & 152.
- 8 MAGNET MUST BE ORIENTED CORRECTLY IN ORDER TO PROPERLY ACTUATE THE COUNTER.
- 9 CRIMP HEIGHT REFERENCE SETTING WAS THE SETTING USED WHEN THE APPLICATOR WAS QUALIFIED AT THE FACTORY. ADJUSTMENT MAY BE NECESSARY WHEN RUNNING APPLICATOR IN THE FIELD.
- 10 SPARE FEED CAM STORAGE LOCATION REFER TO INSTRUCTION SHEET FOR ADDITIONAL INFORMATION.
- 11 TO CONVERT THE APPLICATOR TO A NON-CARRIER CUTTING STYLE, REMOVE ITEM 13 AND ATTACH TO THE LOCATION ON BACK SIDE OF THE HOUSING. REFER TO INSTRUCTION SHEET FOR ADDITIONAL INFORMATION.
- 12 INSULATION RANGE QUOTED IS THAT OF THE TERMINAL.  
 SEAL PN 828905 - INS. DIA RANGE IS Ø2.2-3.0mm  
 SEAL PN 828904 - INS. DIA RANGE IS Ø1.2-2.1mm  
 SEAL PN 828921 - INS. DIA RANGE IS Ø2.1-3.0mm
- 13 APPLY TORQ-SEAL IN ALLEN SOCKET TO FILL HOLE AFTER FLAT HD HAS BEEN ADJUSTED TO CORRECT HEIGHT AT QUALIFICATION. APPLY #1-23419-5 LOC-TITE TO THREADS.

**\*WARNING**  
 ON INSTALLATION, SET WIRE DISC, ITEM 40 TO LARGEST WIRE SIZE SETTING. USE OF SETTINGS BELOW MINIMUM REQUIRED CRIMP HEIGHT SETTING WILL CAUSE DAMAGE TO CRIMP TOOLING.

-77	-27	-25	-22	-21	PART NO	DESCRIPTION	ITEM NO
-	1	1	1	1	2119782-1	FINE ADJUST HEAD ASM, PACIFIC STYLE	251
-	-	-	1	-	2119640-1	PUSH ROD, AIR FEED	250
-	-	-	1	-	2079988-1	BUSHING, LCH5-12, MISUMI	249
-	1	1	1	1	1-22279-3	SPRING, COMPRESSION	246
-	1	1	1	1	2119082-9	CAM, SNAIL, INSULATION ADJUSTMENT	244
-	1	1	1	1	2079764-1	WASHER, WAVE SPRING, CREST-TO-CREST	243

**PACIFIC VERSION**  
 Shown on sheets 3 of 4 & 4 of 4  
 (Atlantic version shown on sheets 1 of 4 & 2 of 4)

SET UP GAUGE	LOC	DIST	REVISIONS			
2119599-1	A	66	REV	DATE	BY	APPV
			-	SEE SHEET 1	-	-

-	1	1	1	1	2119083-1	RETAINER, INSULATION DIAL	242
-	1	1	1	1	7-18023-7	SCR, SKT HD CAP M3 X 4.0	241
-	-	2	-	-	2168400-6	SHCS, LOW HEAD, RoHS, M5 X 16	240
-	-	-	-	1	2119580-1	MECHANICAL FEED ASSEMBLY	239
-	-	-	1	-	2063440-1	AIR FEED MODULE	238
-	-	1	-	-	2119740-2	TAG, IDENTIFICATION	213
-	-	1	-	-	1901094-3	SPACER, FEEDER	198
-	1	1	1	1	1976053-2	LOCATER BLOCK, TERMINAL	179
-	1	1	1	1	993111-1	PIN, SLOTTED SPRING 3.0 X 20.0	177
-	1	1	1	1	8-22280-7	SPRING, COMPRESSION	176
-	1	1	1	1	1752353-2	GUIDE PIN, HOLDDOWN	175
-	1	1	1	1	1901680-2	GUIDE PIN, HOLDDOWN	174
-	-	-	2	-	21045-3	RING, RETAIN, EXTERN, 3/16 CRESCENT	172
-	1	1	1	1	994969-1	MAGNET, RARE EARTH HIGH ENERGY	166
-	REF	REF	REF	REF	994970-2	COUNTER, MAGNETIC	164
-	-	-	1	-	240638-1	SPRING, FEED FINGER	163
-	1	1	1	1	8-21084-1	O-RING, .801 ID, .070 DIA. MAT.	152
-	-	-	1	-	2119641-2	FEED CAM, AIR FEED	151
-	1	1	1	1	2119798-2	DETENT PIN	145
-	1	1	1	1	2079383-8	SCR, BHSC, RoHS (M4 X 16)	144
-	4	4	4	4	2168400-5	SHCS, LOW HEAD, RoHS, M4 X 20	143
-	-	-	-	1	2119653-2	FEED CAM, POST FEED	142
-	1	1	1	1	1-2119656-0	APPLICATOR BASIC ASSEMBLY, SF	141
-	1	1	1	1	2119650-1	RAM, ASIAN STYLE, SIDE FEED	140
-	1	1	1	1	2119092-2	BOLT, ADJUSTMENT	139
-	-	-	1	-	3-23627-7	PIN, RETAIN, GRVD, 3/16 X .854	137
-	-	-	1	-	2119799-1	HOLDER, FEED FINGER, AF	136
-	-	REF	-	-	SEE NOTE 4	MEMORY CHIP, PROGRAMMED	135
-	-	1	-	-	1633743-1	SERVO FEED LATCH ASM	133
-	1	1	1	1	1-18028-2	WASHER, FLAT, REG M4	119
-	-	REF	-	-	2119944-1	FEED FINGER ASSEMBLY, SF	117
-	1	1	1	1	455888-5	SPACER, CRIMPER	82
-	1	1	1	1	2119956-1	DOCUMENTATION PACKAGE	71
-	1	-	1	1	2119740-1	TAG, IDENTIFICATION	67
-	2	2	2	2	2168078-1	SCREW, DRIVE, RH, RoHS, 2 x .188	66
-	2	2	2	2	1-2079383-0	SCR, BHSC, RoHS (M3 X 6)	64
-	1	1	1	1	2119793-1	LIMITER, ADJUSTMENT BOLT	63
-	3	3	3	3	992763-5	SCR, SET, SOC, CONE POINT, M3 X 4.0	62
-	-	-	1	1	5-18022-5	SCR, HEX HD CAP, M4 X 6.0	59
-	1	1	1	1	985575-3	SCR, FLT SKT HD CAP M3 X 10.0	57
-	-	-	1	1	1338685-1	PAWL, FEED	56
-	1	1	1	1	1-5018030-0	NUT, HEX, REG, RoHS, M3.5	52
-	1	1	1	1	1901681-8	HOLDDOWN, TERMINAL	51
-	1	1	1	1	2-1752354-2	STANDOFF, HOLD-DOWN	50
-	-	-	1	2	18023-9	SCR, SKT HD CAP M4 X 6.0	49
-	-	-	-	1	2119652-1	FEED CAM, PRE FEED	48
-	1	1	1	1	2079383-7	SCR, BHSC, RoHS (M8 X 25)	41
-	1	1	1	1	2119645-1	DISC, NUMBERED FA WIRE ADJUSTMENT	40
-	1	1	1	1	2119957-1	APPLICATOR SHIM PACK	39
-	1	1	1	1	2119644-2	RAM WASHER, PRECISION	38
-	1	1	1	1	1-1752356-7	SUPPORT, TERMINAL	34
-	2	2	2	2	2079383-5	SCR, BHSC, RoHS (M4 X 20)	33
-	1	1	1	1	2161328-1	HEX HEAD, FLANGED, M5 X 8mm LONG	32
-	1	1	1	1	1320908-6	SPACER, STRIP GUIDE	30
-	1	1	1	1	2119959-1	ASSEMBLY, STRIP GUIDE	29
-	1	1	1	1	455888-3	SPACER, CRIMPER	28
-	1	1	1	1	1320928-3	STRIP GUIDE	24
-	1	1	1	1	2168083-2	SCR, SKT HD CAP, RoHS, M4 X 8.0	21
-	1	1	1	1	1-18028-2	WASHER, FLAT, REG M4	20
-	1	1	1	1	2119533-1	STRIPPER, SIDE FEED	19
-	1	1	1	1	2119806-1	INSERT, SHEAR	13
-	1	1	1	1	3-22280-3	SPRING, COMPRESSION	12
-	1	1	1	1	1-356885-4	STOP, SHEAR	11
-	1	1	1	1	2119805-1	SHEAR HOLDER, FRONT	10
-	1	1	1	1	318707-1	FLOATING SHEAR, FRONT	9
-	1	1	1	1	1-1333206-6	ANVIL, COMBINATION .100	8
-	-	-	-	-	-	-	7
-	-	-	-	-	-	-	6
-	1	1	1	1	2119781-5	DEPRESSOR, SHEAR	5
-	1	1	1	1	2-238011-1	BLOCK, CRIMPER SPACER	4
-	1	1	1	1	1633996-8	CRIMPER, INSULATION SPECIAL	3
-	1	1	1	1	1-455888-1	SPACER, CRIMPER	2
-	1	1	1	1	456407-6	CRIMPER, WIRE PREMIUM	1

DIMENSIONS:		TOLERANCES UNLESS OTHERWISE SPECIFIED:		OWN	CHK	APPV	DATE	NAME	
mm	0 PLC ±.5	1 PLC ±.13	2 PLC ±.013	3 PLC ±.001	4 PLC ±.0001	ANGLES		TE Connectivity	
								Harrisburg, PA 17105-3608	
								Ocean Side Feed Applicator	
								SIZE	CAGE CODE
								A1	00779
								SCALE	1:2
								SHEET	3 OF 4
								REV	B

REVISONS		DATE	OWN	APVD
LOC	DIST			
A	66			
P. LTH	DESCRIPTION			
-	SEE SHEET 1			

# FEED TYPE MECHANICAL



# PNEUMATIC

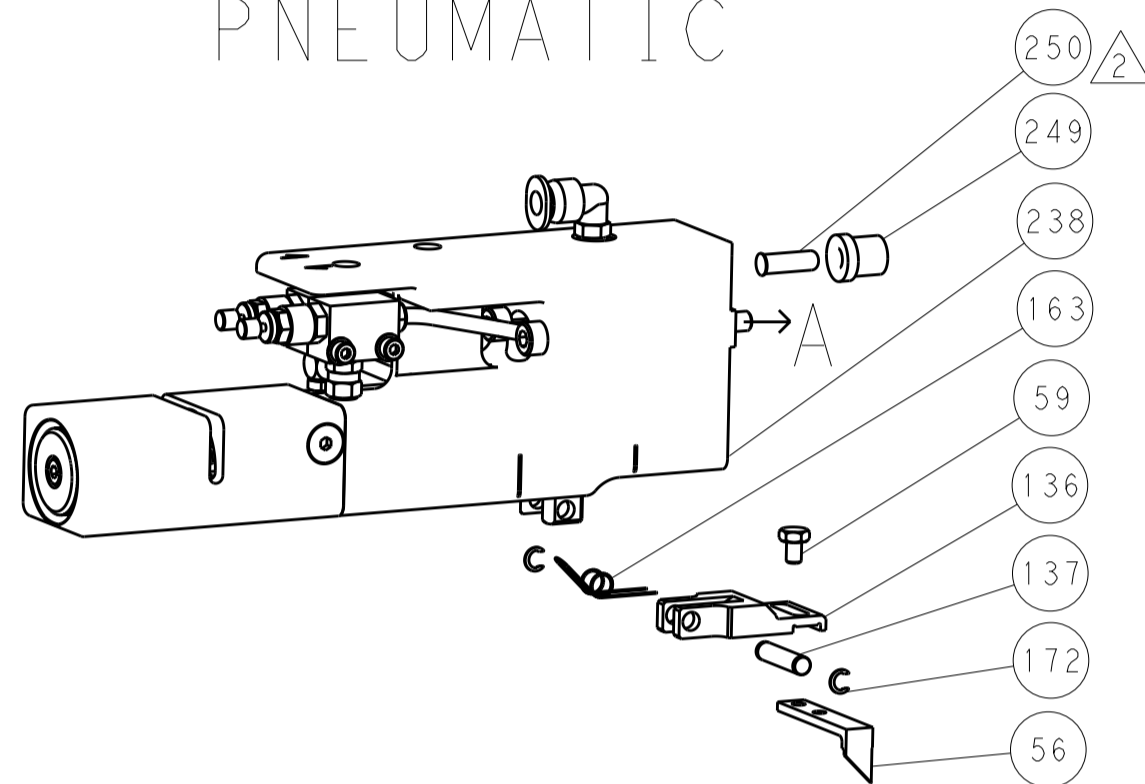

# SERVO LATCH PLATE



# CAM POSITIONS

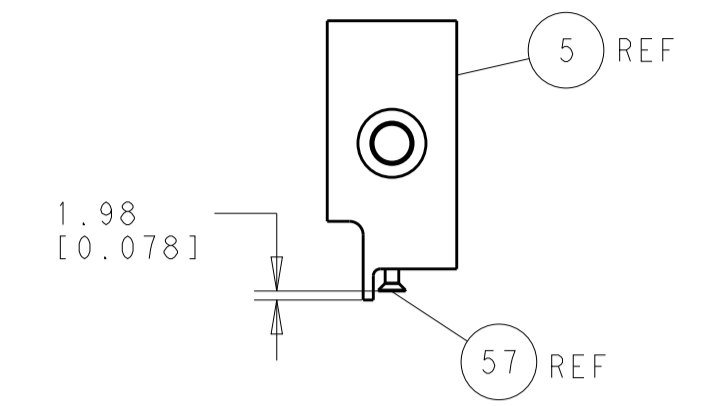
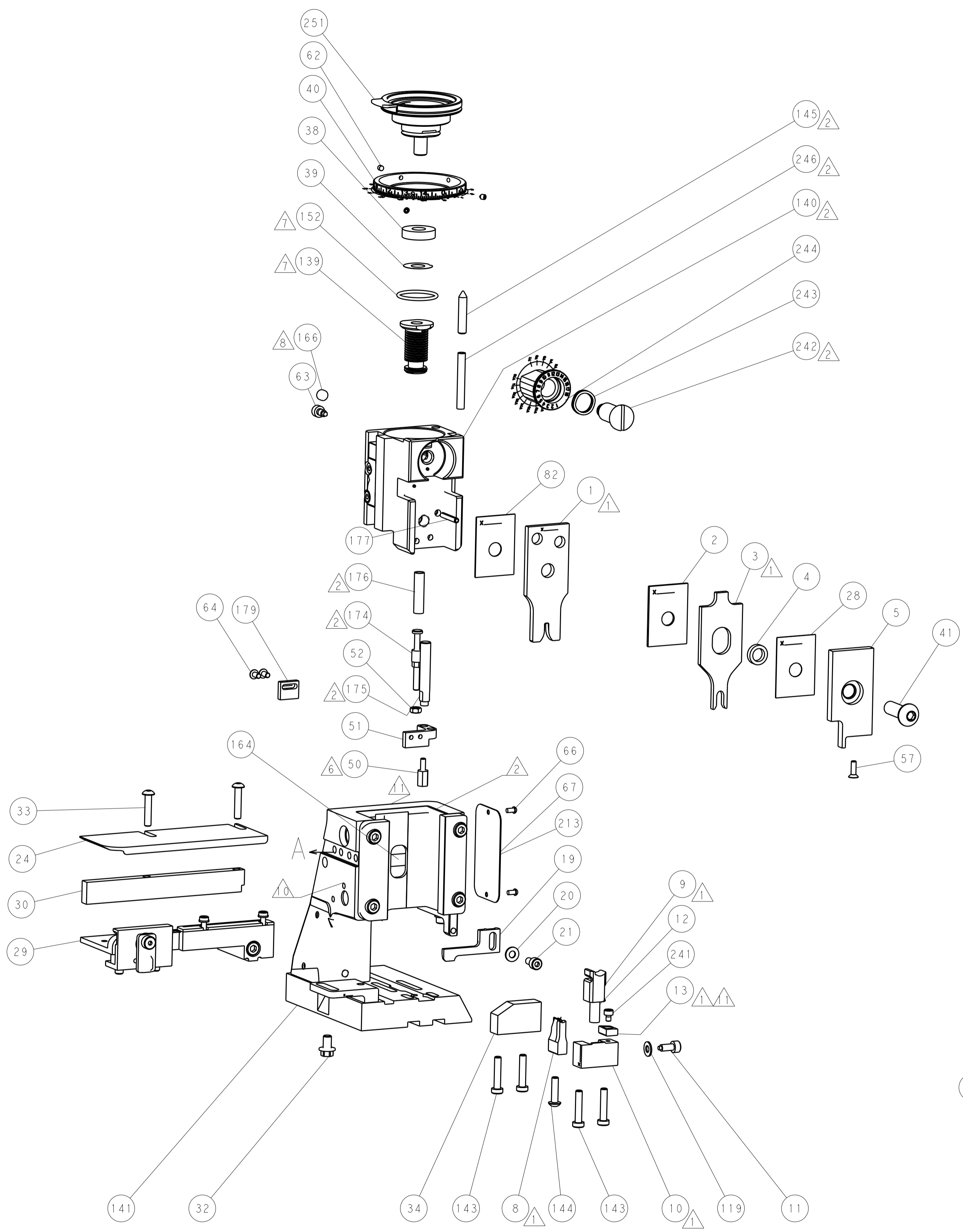

SHEAR DEPRESSOR DETAIL

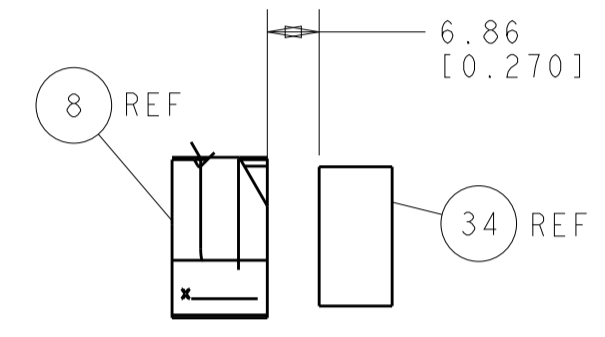

TERMINAL SUPPORT LOCATION

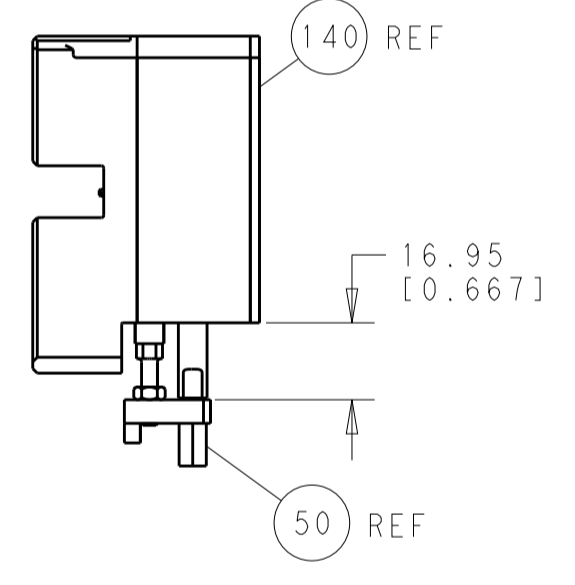

HOLDDOWN SET-UP

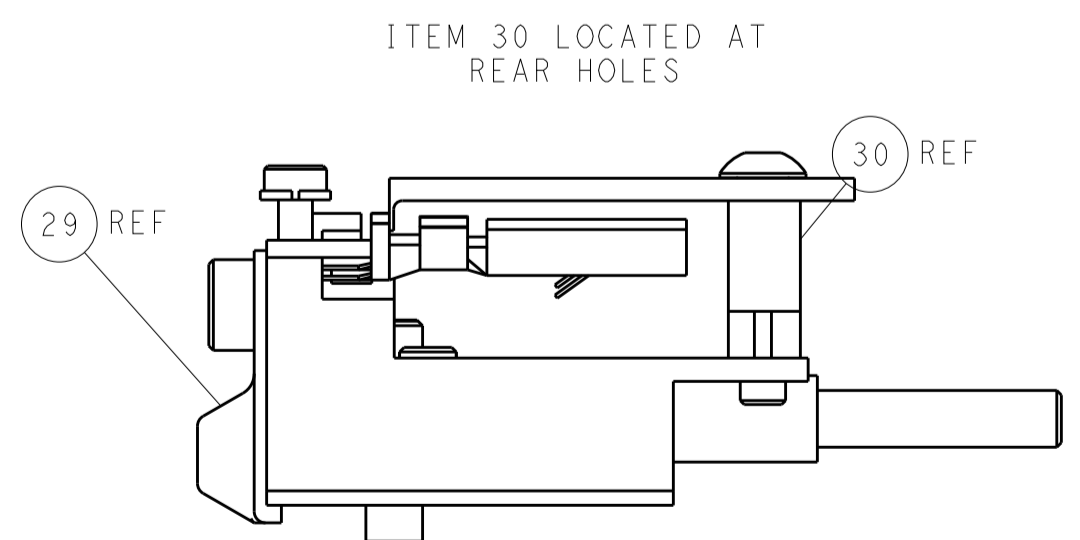

FEED TRACK POSITION GUIDE BY INSULATION BARREL

**PACIFIC VERSION**  
 Shown on sheets 3 of 4 & 4 of 4  
 (Atlantic version shown on sheets 1 of 4 & 2 of 4)

DIMENSIONS:		TOLERANCES UNLESS OTHERWISE SPECIFIED:		DWN Y. YIN 09NOV2011		TE Connectivity	
mm	0 PLC ±0.5	1 PLC ±0.5	2 PLC ±0.13	3 PLC ±0.013	4 PLC ±0.001	APVD S. XI 09NOV2011	Harrisburg, PA 17105-3608
MATERIAL:		FINISH:		NAME		Ocean Side Feed Applicator	
-		-		SIZE		RESTRICTED TO	
-		-		CAGE CODE		DRAWING NO	
-		-		A1 00779		©=2151345	
-		-		WEIGHT		SCALE	
-		-		-		1:2 SHEET 4 OF 4 REV B	
-		-		CUSTOMER ACCESSIBLE PRODUCTION DRAWING		SHEETS 1 & 2 ARE NOT REQUIRED FOR PACIFIC VERSION	