

Electrical Testing
per Tusonix standard
test plans and Mil-Std-202
Test Methods.

MARKETING SALES DRAWING
DIMENSIONS IN INCHES - DO NOT SCALE THIS DRAWING
DIMENSIONS IN METRIC - []

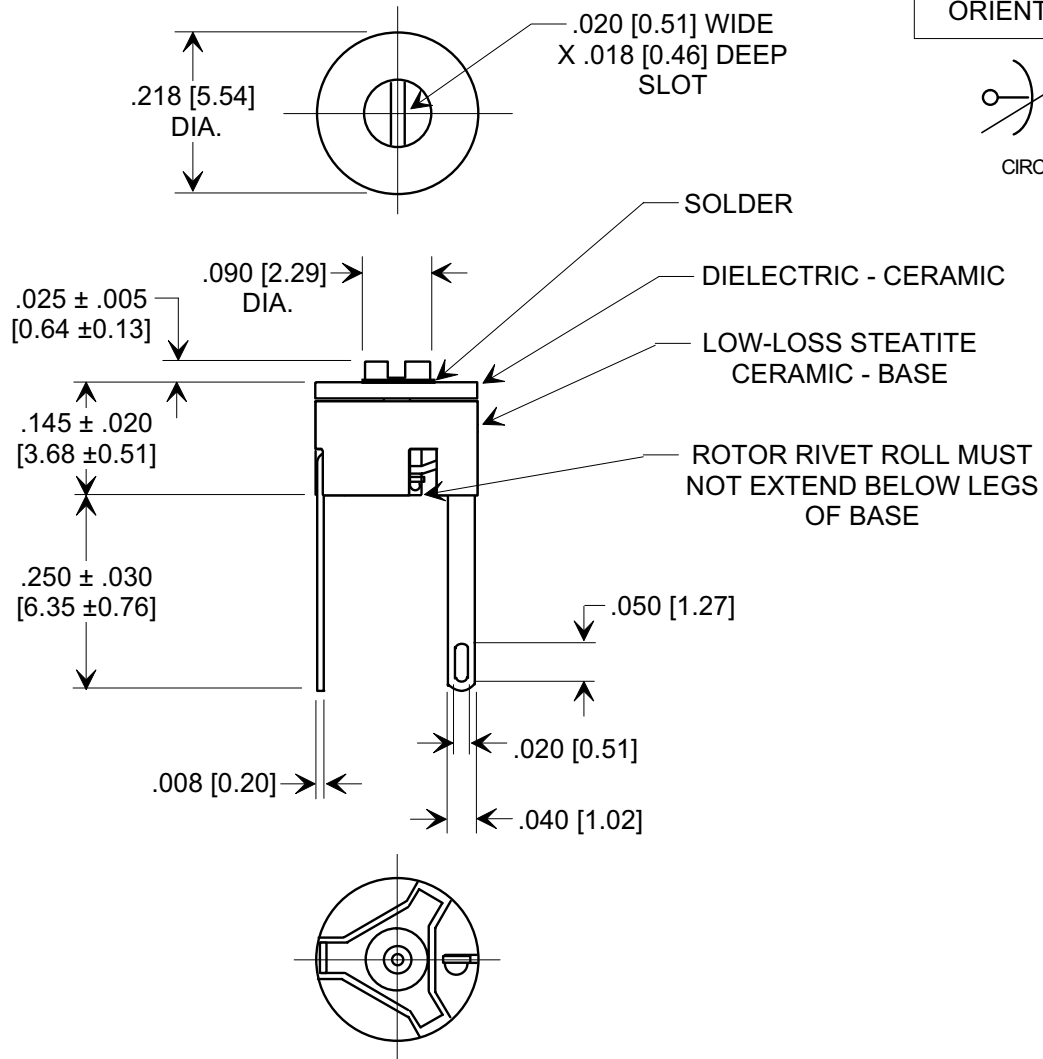
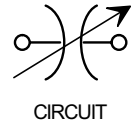
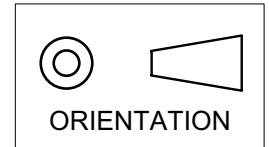

SPECIFICATIONS

TUSONIX PART NO.	518-000 A 3.5-20
Value:	3.5 - 20 pF
Value Tol.:	MIN. + 10%, MAX. -10%
Temp. Coef.:	NP0
Rating:	100 VDC @ 85°C
Operating Range:	-55°C TO + 125°C
To Tusonix Spec Unless Stated Otherwise	

X-2015 Rev-0 REVISION RECORD Original Release C.O. 20001108-3-01	0	TOLERANCES unless otherwise specified 2' PLC. DECIMAL ± 3' PLC. DECIMAL ± .010 [0.25]	Title MINIATURE CERAMIC TRIMMER	
			ANGLES ±	Drawn S.M. 11-09-00
	TUSONIX TUCSON, ARIZONA		Approved T.C. 11-09-00	
			A	518-000-A 3.5-20

Mouser Electronics

Authorized Distributor

Click to View Pricing, Inventory, Delivery & Lifecycle Information:

[Tusonix:](#)

[0518-000-A-3.5-20LF](#)