



SIPSMT10-05 SERIES

10 AMP

POL CONVERTERS



FEATURES

- * Non-isolated POL converter
- * SIP / SMT Package
- * Output Current 10AMP
- * Input Voltage Range 9-14VDC
- * 300KHz Switching Frequency
- * High Efficiency to 95%
- * Over Temperature Protection
- * Continuous Short Circuit Protection
- * Remote ON/OFF Control
- * UL/C-UL60950 Certified

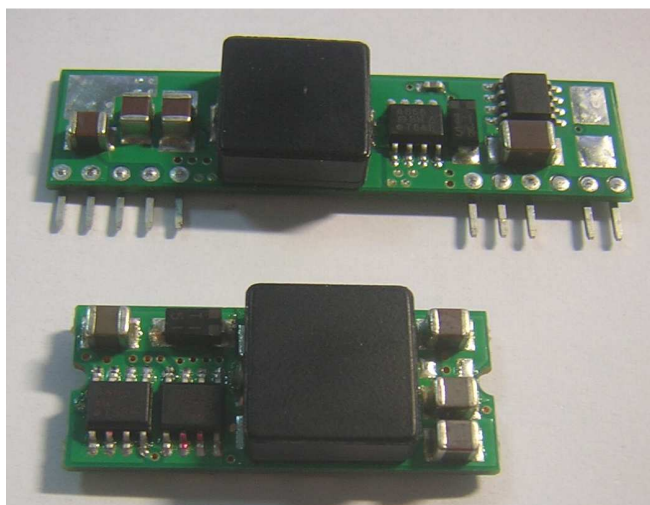

MODEL NUMBER	INPUT VOLTAGE	OUTPUT VOLTAGE	OUTPUT CURRENT	INPUT CURRENT		Efficiency (%)
				NO LOAD	FULL LOAD	
SIP10-05S10 SMT10-05S10	3.0 – 5.5VDC	1.0VDC	10A	50mA	2353mA	85
SIP10-05S12 SMT10-05S12	3.0 – 5.5VDC	1.2VDC	10A	50mA	2791mA	86
SIP10-05S15 SMT10-05S15	3.0 – 5.5VDC	1.5VDC	10A	50mA	3409mA	88
SIP10-05S18 SMT10-05S18	3.0 – 5.5VDC	1.8VDC	10A	50mA	4000mA	90
SIP10-05S20 SMT10-05S20	3.0 – 5.5VDC	2.0VDC	10A	60mA	4396mA	91
SIP10-05S25 SMT10-05S25	3.0 – 5.5VDC	2.5VDC	10A	60mA	5376mA	93
SIP10-05S33 SMT10-05S33	4.5 – 5.5VDC	3.3VDC	10A	60mA	6947mA	95

NOTE: Nominal Input Voltage 5.0VDC

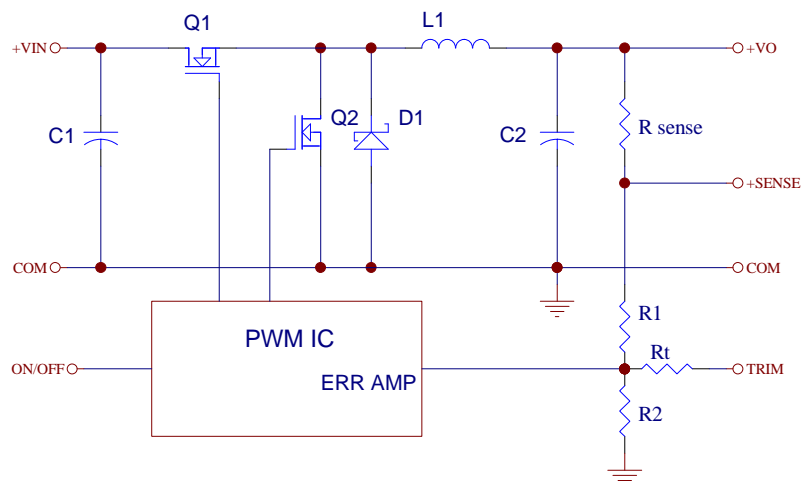

Figure 1. Simplified Schematic

SPECIFICATIONS

All Specifications Typical At Nominal Line, Full Load, and 25°C Unless Otherwise Noted

INPUT SPECIFICATIONS:

Input Voltage Range	5V	3.0 – 5.5V
	5V	4.5 – 5.5V
Under Voltage Lock-out	Power up	2.8V typ.
	Power down	2.7V typ.
Input Filter Type	Capacitive	
Positive Remote on/off Control:		
Module ON	Open Circuit or = Vin	
Module OFF	<0.4Vdc	

OUTPUT SPECIFICATIONS:

Voltage Accuracy	±1.5% max.
Transient Response: 25% Step Load Change	<200us
Ripple and Noise, 20MHz BW (note 3)	20mVrms max.
	50mVpk-pk max.
Temperature Coefficient	±0.03%/C max.
Short Circuit Protection	Continuous
Line Regulation (note 1)	±0.2% max.
Load Regulation (note 2)	±0.5% max.
Capacitive Load, Low ESR	10000uF max.
External Trim Adj. Range	±10%
Start up time	4.5ms typ.

GENERAL SPECIFICATIONS:

Efficiency	See Table
Isolation Voltage	Non-isolation
Switching Frequency	300KHz typ.
Over Temperature Protection	120°C typ.
Operating Ambient Temperature Range	-40°C to +85°C
Power Derating Curve	see Figure2, 3
Storage Temperature Range	-55°C to +125°C
MTBF	MIL-STD-217F, GB, 25°C, Full Load 1.5Mhrs typ.
Dimensions: SIP Package:	2.00x0.52x0.33 inches (50.8x13.2x8.3 mm)

SMT Package: 1.30x0.530x0.366 inches (33.0x12.46x9.3 mm)

Structure	Non-potted With Open Frame Type
Weight	6.8g

NOTE :

1. Measured From High Line to Low Line
2. Measured From Full Load to Zero Load
3. The output noise is measured with 10uf tantalum capacitor and 1uf ceramic capacitor across output.
4. The Input Terminal Recommend to Parallel With 100uF Capacitor ESR<20mΩ to Reduce The Input Ripple Voltage
5. Suffix "N" to the Model Number with Negative Logic Remote on/off
 Model ON Open Circuit or < 0.4VDC
 Module OFF >+2.8VDC to Vin

Dimensions:

SIP Packages

Mechanical Specification
 All Dimensions In Inches (mm)
 Tolerances Inches: X.XX= ±0.02 , X.XXX= ±0.010
 Millimeters: X.X= ±0.5 , X.XX=±0.25

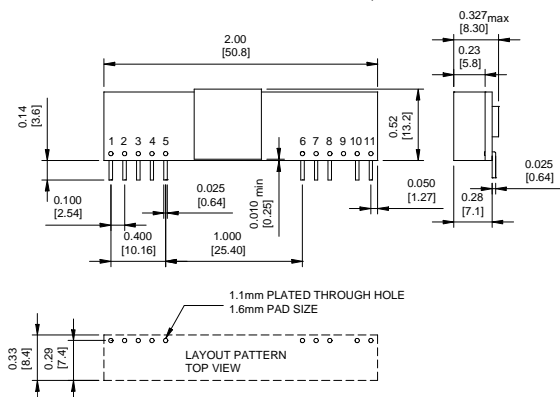

Pin	FUNCTION
1	+Output
2	+Output
3	+Sense
4	+Output
5	Common
6	Common
7	+V Input
8	+V Input
9	No Pin
10	Trim
11	On/Off Control

SMT Packages

Bottom View of Board

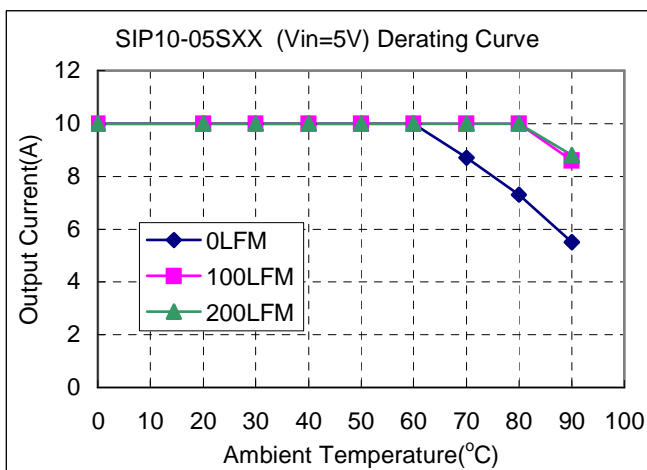
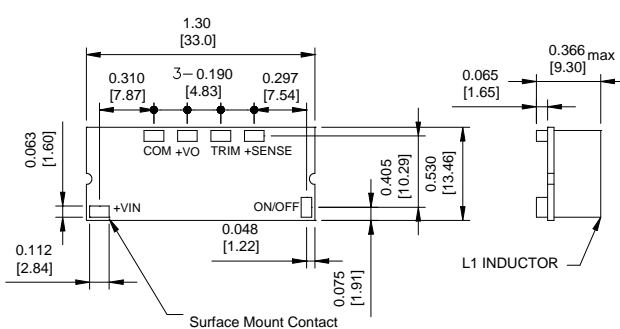

Figure2. Typical Power De-rating for 5V IN

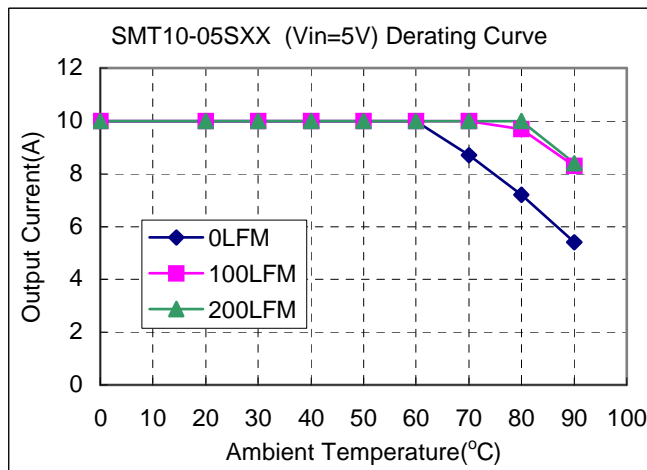

Figure3. Typical Power De-rating for 5V IN