

THIS DOCUMENT IS THE PROPERTY OF
KEYSTONE ELECTRONICS CORP. AND
SHALL NOT BE REPRODUCED, DISTRIBUTED
OR USED AS A BASIS FOR MANUFACTURE
WITHOUT PRIOR WRITTEN PERMISSION
FROM KEYSTONE ELECTRONICS CORP.

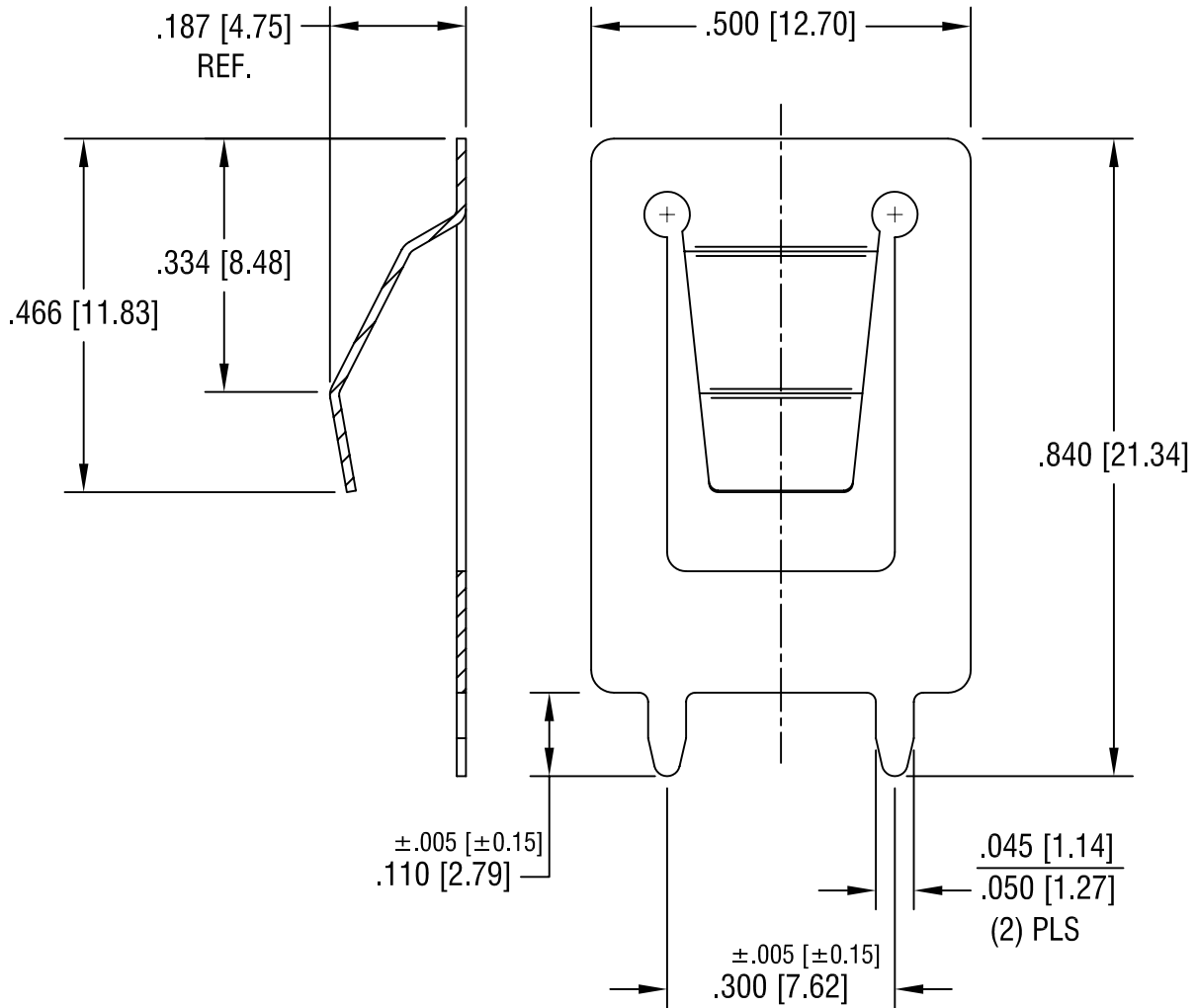

NOTE:

1. HEAT TREAT TO SPRING TEMPER

KEYSTONE ELECTRONICS CORP.			
ASTORIA, N.Y. 11105-2017			
PART NAME			
PC BATTERY CONTACT			
MATERIAL			
.012 [.30] TH'K ANNEALED SPRING STEEL			
FINISH		DRN BY	DATE
NICKEL PLATE		BOONE	12.21.93
		APPD	SCALE
		LN	4X
TOLERANCES		INCH	[MM]
DECIMAL		± .010	[± 0.25]
ANGULAR		± 1°	
UNLESS OTHERWISE SPECIFIED		CODE	DWG NO.
		C	109-2

DATE	DESCRIPTION	REV.