

THIS DRAWING IS UNPUBLISHED. RELEASED FOR PUBLICATION 20
 © COPYRIGHT 20 BY - ALL RIGHTS RESERVED.

REVISIONS				
P	LTR	DESCRIPTION	DATE	APVD
7		REMOVE PRELIM NOTE	10AUG2017	MM MM

NOTES:

- 1 MATERIALS AND FINISH:
 -MODULE HOUSING: PBT, COLOR: GREY
 -CONTACTS: BRASS, FINISH: Sn OVER Ni
 -O-RING: SILICON RUBBER, COLOR: BLACK
- 2. MUST COMPLY WITH DIRECTIVE 2002/95/EC (ROHS)
- 3 LOCATION OF FLAT ON RECEPTACLE (TE P/N 2213858-1)
 THREAD SECTION IN FULL MATED POSITION

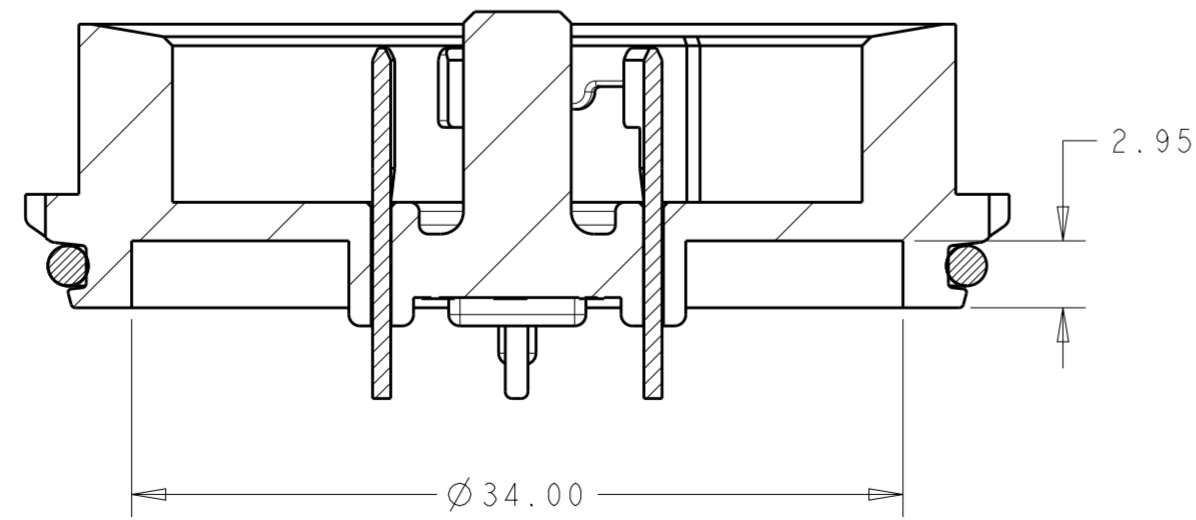
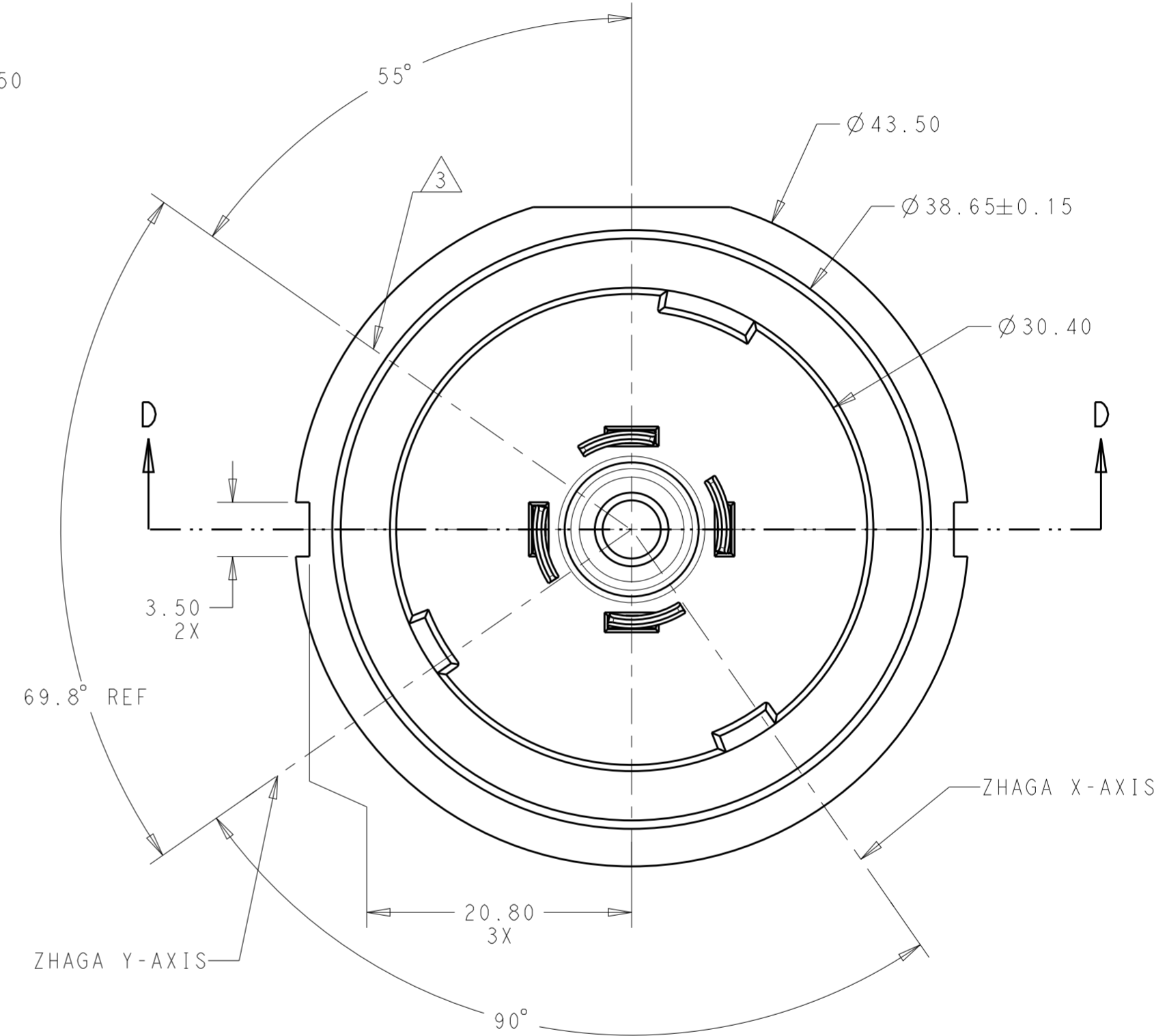
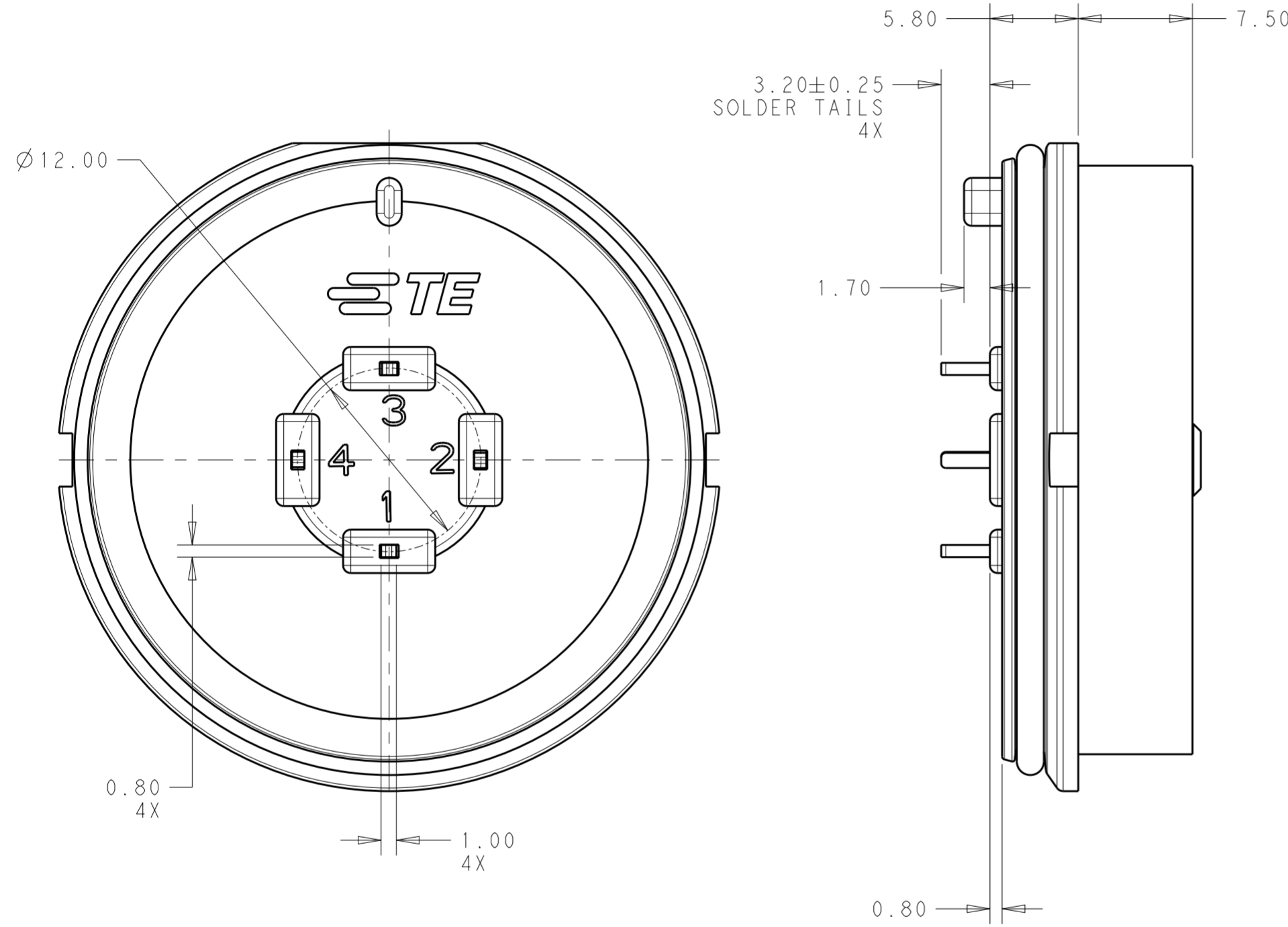

SECTION D-D

STANDARD	2213837-1
DESCRIPTION	PART NO.

THIS DRAWING IS A CONTROLLED DOCUMENT.		DWN C. DAILY 18MAY2016	STE TE Connectivity	
		CHK M. MOSTOLLER 18MAY2016		
DIMENSIONS: mm		APVD -		NAME MODULE BASE ASSEMBLY, LUMAWISE ENDURANCE S 40mm DIAMETER
TOLERANCES UNLESS OTHERWISE SPECIFIED:		PRODUCT SPEC 108-133073		SIZE A2
0 PLC ±	1 PLC ±0.2	APPLICATION SPEC 114-133074		CAGE CODE -
2 PLC ±0.15	3 PLC ±0	WEIGHT -		DRAWING NO. G-2213837
4 PLC ±0	ANGLES ±1°	CUSTOMER DRAWING		RESTRICTED TO -
FINISH -	-	SCALE 3:1		SHEET 1 OF 2
MATERIAL SEE NOTES		REV 7		

THIS DRAWING IS UNPUBLISHED. RELEASED FOR PUBLICATION 20
 © COPYRIGHT 20 BY - ALL RIGHTS RESERVED.

REVISIONS					
P	LTR	DESCRIPTION	DATE	DWN	APVD
-	-	SEE SHEET 1	-	-	-

LATCH DETAIL
SECTION F-F
SCALE 3:1

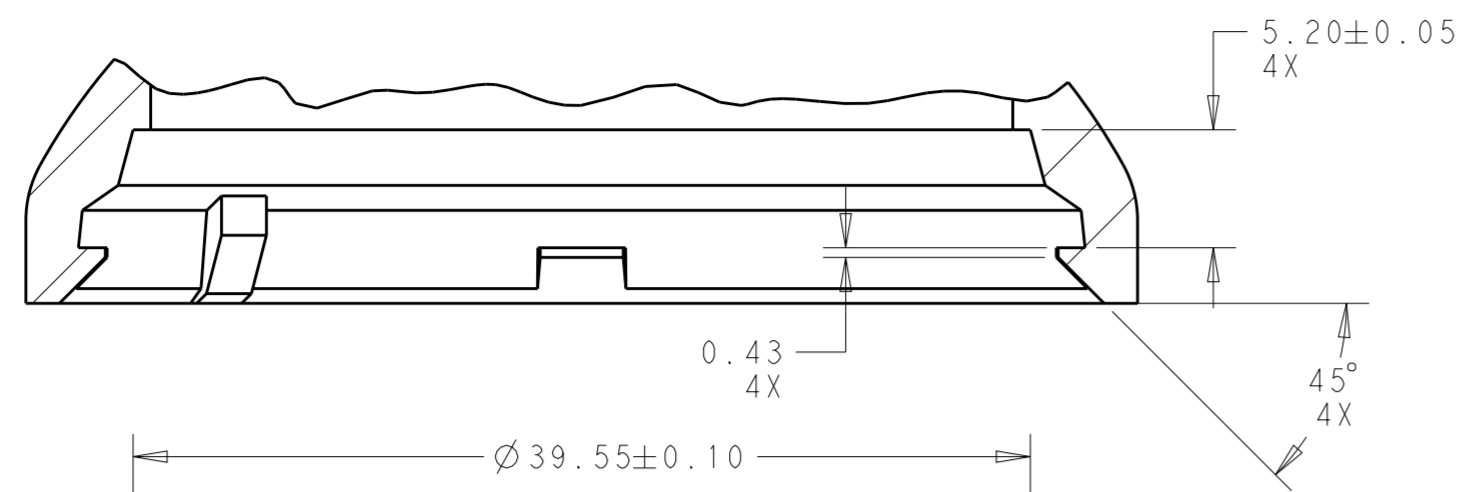

KEY DETAIL
SECTION E-E

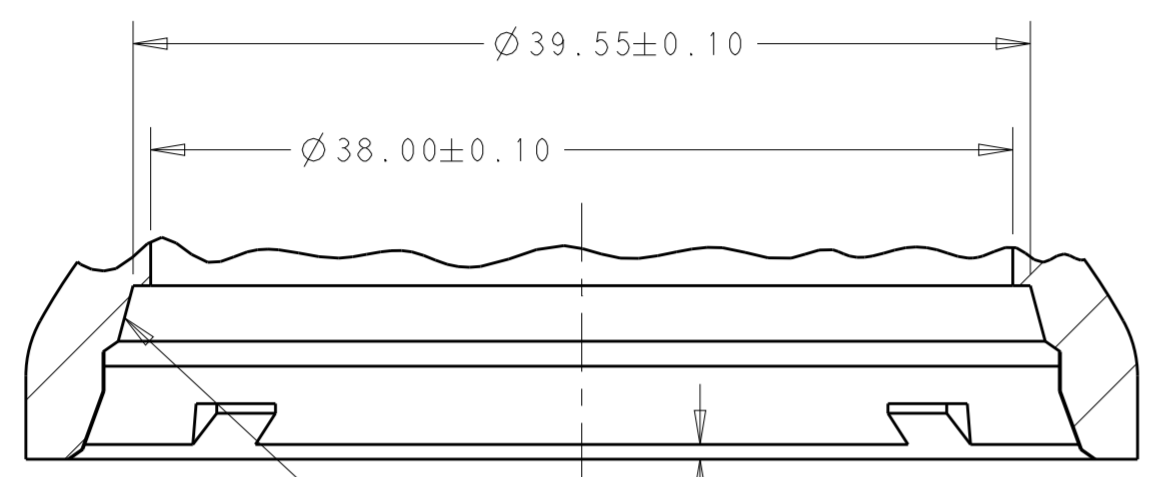

O-RING SEALING SURFACE.
MUST BE SMOOTH AND
FREE OF DEFECTS

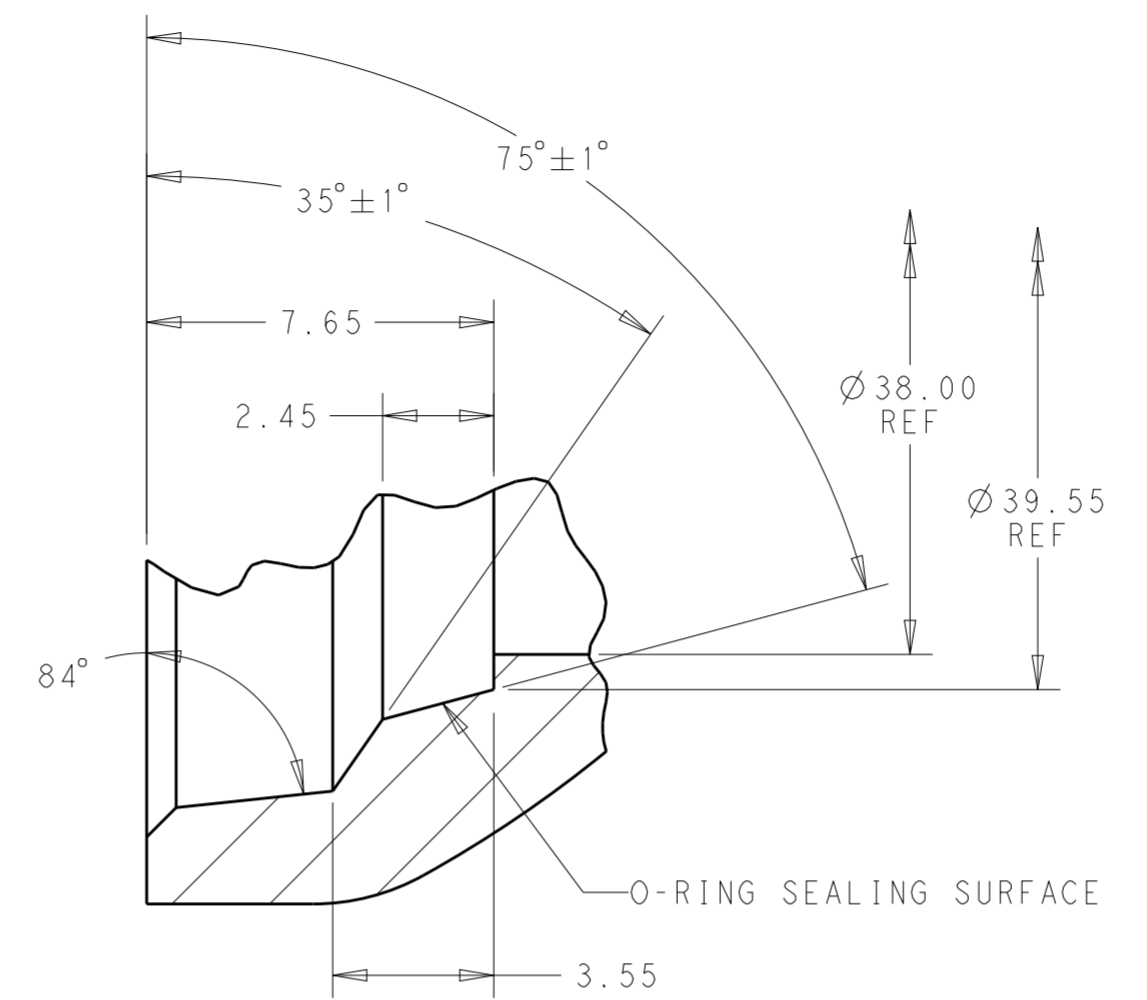

SECTION G-G
SCALE 6:1

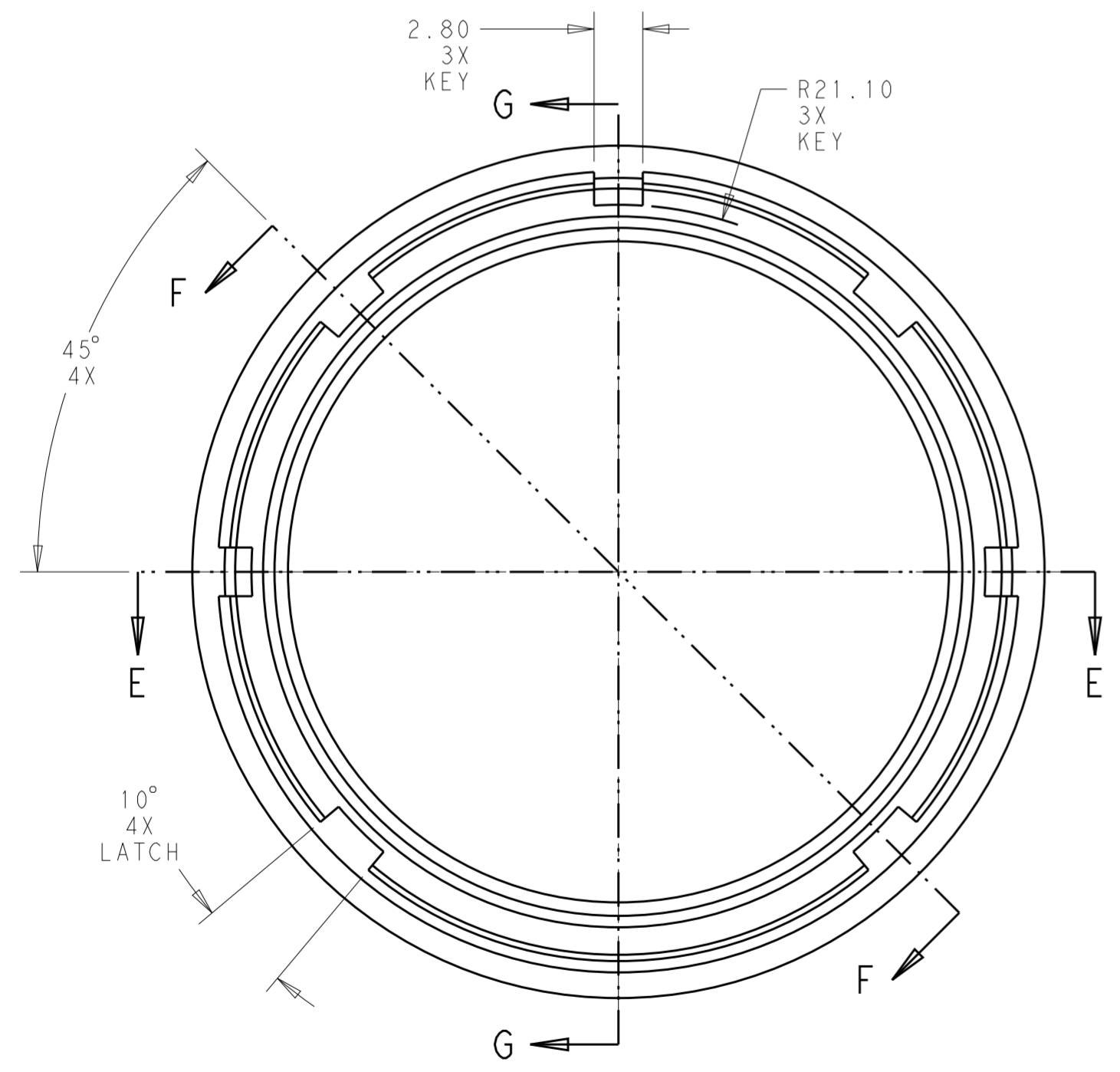
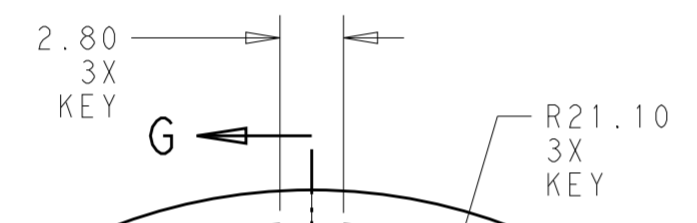

RECOMMENDED
CAP SEAL AND LATCH DETAIL
SCALE 3:1

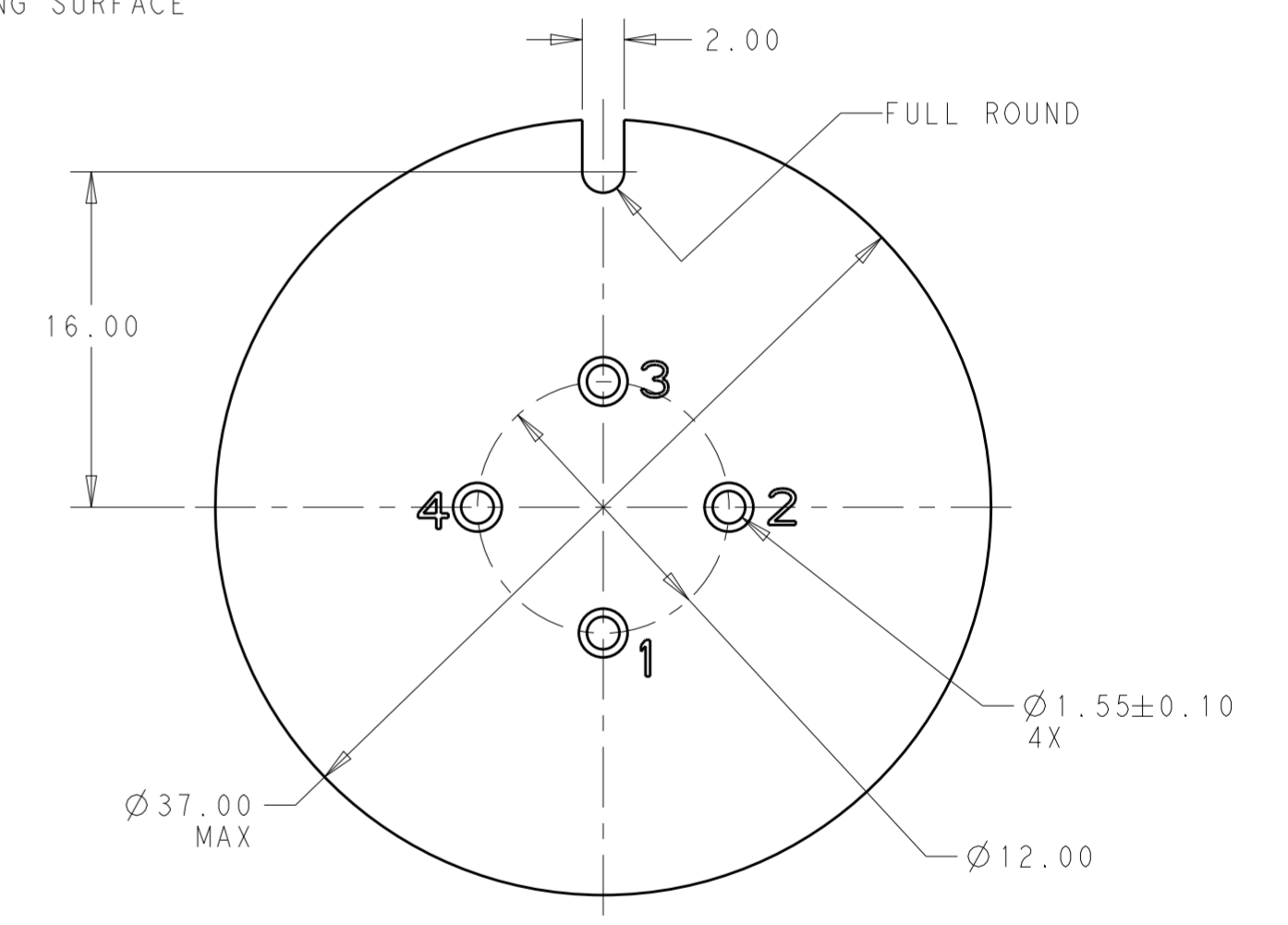

PROPOSED PCB LAYOUT
SCALE 3:1

THIS DRAWING IS A CONTROLLED DOCUMENT.		DWN C. DAILY 18MAY2016	TE Connectivity		
		CHK M. MOSTOLLER 18MAY2016			
DIMENSIONS: mm		TOLERANCES UNLESS OTHERWISE SPECIFIED:		NAME MODULE BASE ASSEMBLY, LUMAWISE ENDURANCE S 40mm DIAMETER	
		0 PLC ±	1 PLC ±0.2	PRODUCT SPEC 108-133073	
		2 PLC ±0.15	3 PLC ±0	APPLICATION SPEC 114-133074	
		4 PLC ±0	ANGLES ±1°	SIZE A2	
MATERIAL SEE NOTES		FINISH -	WEIGHT -	CAGE CODE -	
				DRAWING NO G-2213837	
				RESTRICTED TO -	
				SCALE 3:1	SHEET 2 OF 2
					REV 7