



Main

Range of product	Preventa Safety automation
Product or component type	Safe output expansion module
Device short name	XPSMCM
Electrical connection	Screw terminal
[Us] rated supply voltage	24 V (- 20...20 %) DC
Number of inputs	2 digital external device monitoring
Number of outputs	2 safety outputs OSSD contactor/drive connection 2 configurable diagnostic connection
Discrete input type	Isolated
Discrete output type	PNP
Function of module	Discrete output monitoring safety actuators

Complementary

Power consumption in W	<= 3 W
Power dissipation in W	3 W
Integrated connection type	Backplane expansion bus
Number of terminal blocks	4
Connections - terminals	2-wire captive screw clamp terminals, removable terminal block 1-wire captive screw clamp terminals, removable terminal block
Load type	Resistive load
Safety level	Can reach SIL 3 conforming to EN/IEC 61508 SILCL 3 conforming to IEC 62061 Can reach category 4 conforming to EN/ISO 13849-1 Can reach PL = e conforming to EN/ISO 13849-1
Quality labels	CE
Discrete input voltage	24 V DC
Discrete output voltage	24 V DC
Discrete output current	400 mA 100 mA
Output load	60 Ohm
Local signalling	1 LED green with PWR marking power ON 1 LED green with RUN marking RUN (status) 1 LED red with E IN marking internal error 1 LED red with E EX marking external error 2 LEDs green/red with OUT marking output status 2 LEDs yellow with RST marking restart signal 2 LEDs orange with ADDR marking node address 2 LEDs yellow with STATUS marking output status
Cable cross section	(0.2...1.5 mm ² - AWG 24...AWG 16) flexible cable without cable end (0.2...2.5 mm ² - AWG 24...AWG 14) flexible cable without cable end (0.25...1 mm ² - AWG 23...AWG 18) flexible cable with cable end, without bezel (0.25...2.5 mm ² - AWG 23...AWG 14) flexible cable with cable end, with bezel (0.5...1.5 mm ² - AWG 20...AWG 16) flexible cable with cable end, with double bezel (0.2...1 mm ² - AWG 24...AWG 18) solid cable without cable end (0.2...2.5 mm ² - AWG 24...AWG 14) solid cable without cable end (0.25...2.5 mm ² - AWG 23...AWG 14) flexible cable with cable end, without bezel
Mounting support	Omega 35 mm DIN rail conforming to EN 50022
Depth	0.89 in (22.5 mm)
Height	3.9 in (99 mm)
Width	4.51 in (114.5 mm)
Product weight	0.51 lb(US) (0.23 kg)

The information provided in this documentation contains general descriptions and/or technical characteristics of the products contained herein. This documentation is not intended as a substitute for and is not to be used for determining suitability or reliability of these products for specific user applications. It is the duty of any such user or integrator to perform the appropriate and complete risk analysis, evaluation and testing of the products with respect to the relevant specific application or use thereof. Neither Schneider Electric Industries SAS nor any of its affiliates or subsidiaries shall be responsible or liable for misuse of the information contained herein.

Environment

standards	EN/IEC 61508 EN/IEC 61800-5-1 EN/ISO 13849-1 IEC 62061
product certifications	CULus TÜV RCM
IP degree of protection	IP20 enclosure
ambient air temperature for operation	14...131 °F (-10...55 °C)
ambient air temperature for storage	-20...85 °C
relative humidity	10...95 %
pollution degree	2
[Uimp] rated impulse withstand voltage	4 kV conforming to EN/IEC 61800-5-1
safety reliability data	DC > 99 % MTTFd < 100 years at high PFHd = 3.16E-9 1/h
insulation	250 V AC between power supply and housing conforming to EN/IEC 61800-5-1
overvoltage category	II
electromagnetic compatibility	Electrostatic discharge immunity test - test level 6 kV, on contact conforming to EN/IEC 61000-4-2 Electrostatic discharge immunity test - test level 20 kV, on air conforming to EN/IEC 61000-4-2 Susceptibility to electromagnetic fields - test level 10 V/m, 80...1000 MHz conforming to EN/IEC 61000-4-3 Susceptibility to electromagnetic fields - test level 30 V/m, 1.4 GHz...2 GHz conforming to EN/IEC 61000-4-3
vibration resistance	+/-0.35 mm (f = 10...55 Hz) conforming to EN/IEC 61496-1
shock resistance	10 gn (duration = 16 ms) shocks : 1000 shocks on each axis EN/IEC 61496-1
service life	20 yr

Offer Sustainability

Green Premium product	Green Premium product
Compliant - since 1450 - Schneider Electric declaration of conformity	Compliant - since 1450 - Schneider Electric declaration of conformity
Reference not containing SVHC above the threshold	Reference not containing SVHC above the threshold
Available	Available
Available	Available
WARNING: This product can expose you to chemicals including:	WARNING: This product can expose you to chemicals including:
Lead and lead compounds, which is known to the State of California to cause cancer and birth defects or other reproductive harm.	Lead and lead compounds, which is known to the State of California to cause cancer and birth defects or other reproductive harm.
For more information go to www.p65warnings.ca.gov	For more information go to www.p65warnings.ca.gov

Dimensions

Screw Terminal

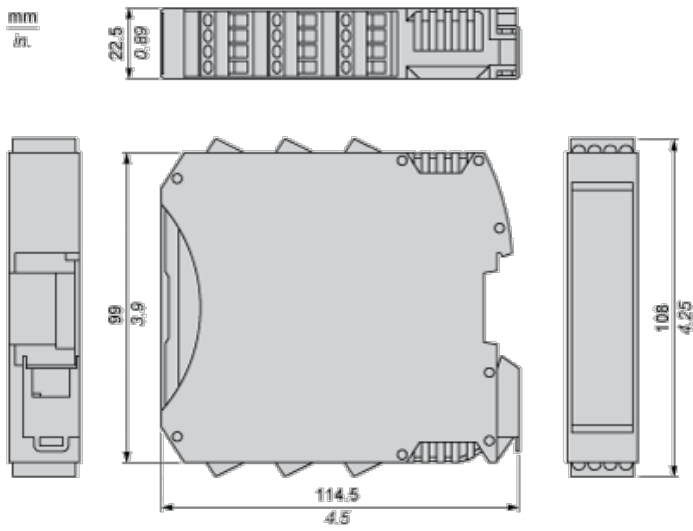

Mounting Safety Controller CPU with Module(s)

Mount BackPlane Connector on Rail

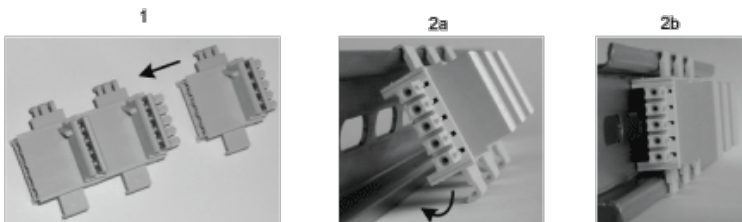

- 1 : Connect as much Backplane Connector as module to be install.
- 2 : Fix the connectors to the rail (Top first).

Mount Safety Controller CPU with Other Module(s)

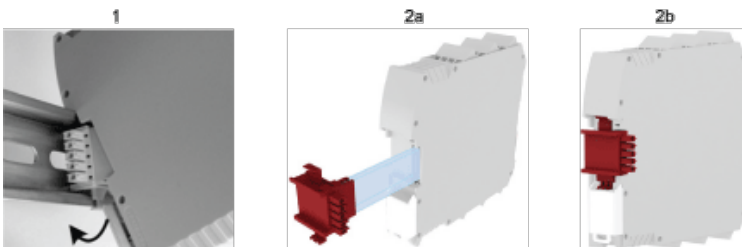

- 1 : Mount controller CPU and modules on rail.
- 2 : Make sure that the controller CPU or the module(s) are plugged on the BackPlane connector.

Wiring

Terminal Designation

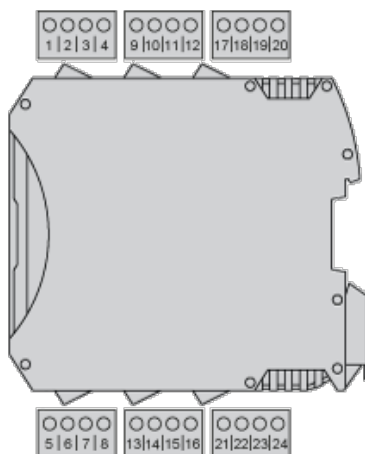

Terminal	Description
----------	-------------

1	24 Vdc power supply
2	Node selection
3	
4	0 Vdc power supply
5	Static output 1
6	
7	Feedback/Restart 1
8	Condition of outputs 1A/1B
9	Static output 2
10	
11	Feedback/Restart 2
12	Condition of outputs 2A/2B
13	24 Vdc power supply
14	-
15	0 Vdc power supply
16	-

Wiring Example

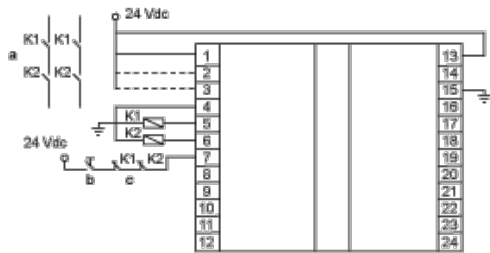

- a : Contractors
- b : Restart
- c : Feedback