

NOTES:

1. MATERIALS AND FINISHES:
 BODY - BRASS, GOLD PLATING
 REAR BODY, SLEEVE & BUSHING - BRASS, NICKEL PLATING
 INNER & OUTER CONTACT - BeCu, GOLD PLATING
 INSULATOR - PTFE, NATURAL
 RETAINING RING - BeCu, NATURAL
 WASHER - CARBON STEEL, NICKEL PLATING
2. ELECTRICAL:
 A. IMPEDANCE: 50 OHM
 B. FREQUENCY RANGE: DC - 18 GHz
 C. VSWR (RETURN LOSS): 1.14 MAX (-23.69 dB MIN)
 D. DWV: 1500 VRMS MIN
 E. INSERTION LOSS: 0.15 dB MAX @ 6 GHz
3. MECHANICAL:
 A. DURABILITY: 500 CYCLES MIN.
 B. TEMPERATURE RANGE: -65°C TO +165°C
4. ENVIRONMENTAL:
 A. THERMAL SHOCK PER MIL-STD-202 METHOD 107 TEST CONDITION B
 B. VIBRATION: MIL-STD-202 METHOD 204 TEST CONDITION D
 C. SHOCK: MIL-STD-202 METHOD 213 TEST CONDITION I
 D. CORROSION: MIL-STD-202 METHOD 101 TEST CONDITION B
 E. MOISTURE RESISTANCE: MIL-STD-202, METHOD 106

5. INSTRUCTIONS:
 1. WHEN THE BARREL IS SNAPPED INTO THE FORWARD POSITION THE CONNECTOR CAN BE USED AS A STANDARD SMA PLUG. TURN THE INDICATED KNURLED AREA BY HAND TO FULLY MATE OR UNMATE THE THREADED INTERFACE.
 2. QUICK CONNECT FUNCTION:
 A. WITH THE BARREL IN THE BACK POSITION, SLIDE THE CABLED ADAPTER ON TO THE JACK RECEPTACLE, OVER THE JACK THREADS BY PUSHING ON THE BACK OF THE KNURLED BODY.
 B. WHILE GENTLY PRESSING THE KNURLED BODY FORWARD, SNAP THE BARREL FORWARD TO ENGAGE THE ADAPTER WITH THE THREADS OF THE JACK CONNECTOR.
 C. ONCE THE BARREL IS FULLY SNAPPED FORWARD, TURN THE INDICATED KNURLED BODY IN ORDER TO OBTAIN THE FULLY MATED INTERFACE. A COMPLETE MATE CAN BE OBTAINED WITH ONE FULL TURN OR LESS.
 D. UNMATE THE ADAPTER BY SLIGHTLY LOOSENING THE THREADS BY TURNING THE INDICATED KNURLED BODY. THEN PULL THE BARREL INTO THE SNAPPED BACK POSITION AND REMOVE THE ADAPTER.
6. PACKAGING:
 A. QUANTITY: SINGLE PACK
 B. MARKING: BAG TO BE MARKED "AMPHENOL RF, 901-10565, DATE CODE"

THIRD ANGLE PROJ.

| REVISIONS | | | | |
|-----------|---------------------------------------|-----------|-------|------|
| REV | DESCRIPTION | DATE | ECN | APPR |
| A | RELEASE TO MFG. | 26-Nov-18 | 09744 | BEW |
| B | UPDATED INSTRUCTION NOTES FOR CLARITY | 18-Jan-19 | 10243 | BEW |

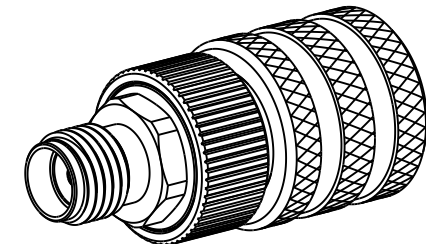

SCALE 2.000

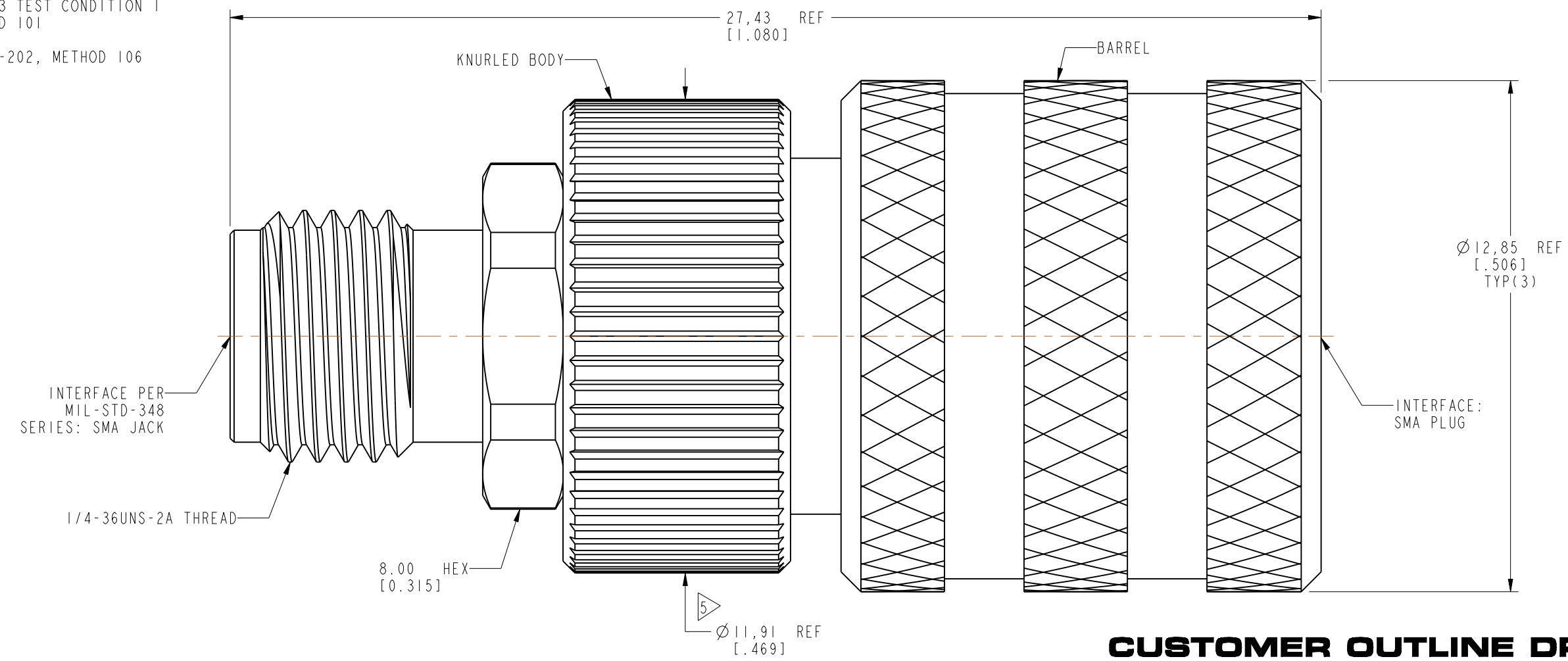

CUSTOMER OUTLINE DRAWING
 ALL OTHER SHEETS ARE FOR INTERNAL USE ONLY

| | | | | | | |
|---|------------------------------|----------|-----------|---|--------------------|-----------------------------------|
| UNLESS OTHERWISE SPECIFIED, DIMENSIONS ARE IN METRIC AND TOLERANCES ARE: <0.5mm ±0.05mm 0.5 - 6mm ±0.1mm 6 - 30mm ±0.2mm 30 - 120mm ±0.3mm ANGLES ±1° | MATERIAL | DRAWN | DATE | TITLE | | Amphenol RF www.amphenolrf.com |
| | SEE NOTES | W. ZENG | 28-Nov-18 | SMA STR JACK TO PLUG ADAPTER, QUICK CONNECT | | |
| NOTICE - These drawings, specifications, or other data (1) are, and remain the property of Amphenol corp. (2) must be returned upon request; and (3) are confidential and not to be disclosed to any person other than those to whom they are given by Amphenol Corp. the furnishing of these drawings, specifications, or other data by Amphenol Corp., or to any other person to anyone for any purpose is not to be regarded by implication or otherwise in any manner licensing, granting rights to permitting such holder or any other person to manufacture, use or sell any product, process or design, patented or otherwise, that may in any way be related to or disclosed by said drawings, specifications, or other data. | REFERENCE | ENGINEER | DATE | SCALE: 8.0:1.0 SHEET 2 OF 2 | | DRAWING NO. 901-10565 |
| | EAR# 7448 | S. DUAN | 29-Nov-18 | DWG SIZE B | | ITEM NO. 901-10565 |
| | REF: -- | APPROVED | DATE | REV | PART NO. 901-10565 | |
| | CONFIGURATION LEVEL: In Work | FIGO | 29-Nov-18 | B | | |
| FINISH | CAD FILE | | | | | |