

# FP1007R6

## High frequency, high current power inductors



**SMD Device**

### Product features

- 10.5 x 8.0 x 7.0mm Maximum surface mount package
- Ferrite core material
- Controlled DCR tolerance for sensing circuits
- Inductance Range from 150nH to 470nH
- Current range from 23.5 to 75 Amps
- Frequency range up to 2MHz
- Halogen free, lead free, RoHS compliant

### Applications

- Multi-phase regulators
- Voltage Regulator Modules (VRMs)
- Desktop and server VRMs and EVRDs
- Data networking and storage systems
- Graphics cards and battery power systems
- Point-of-Load modules
- DCR Sensing

### Environmental data

- Storage temperature range (component):  
-40 °C to +125 °C
- Operating temperature range: -40 °C to +125 °C  
(ambient plus self-temperature rise)
- Solder reflow temperature:  
J-STD-020 (latest revision) compliant



Product Specifications							
Part Number <sup>7</sup>	OCL <sup>1</sup> ±10% (nH)	FLL <sup>2</sup> Min. (nH)	I <sub>rms</sub> <sup>3</sup> (Amps)	I <sub>sat</sub> 1 <sup>4</sup> @25°C (Amps)	I <sub>sat</sub> 2 <sup>5</sup> @100°C (Amps)	DCR @20°C (mΩ)	K-Factor <sup>6</sup>
FP1007R6-R15-R	150	108	61	75.0	60.0	0.29 ± 5%	348.8
FP1007R6-R18-R	180	129		60.0	50.0		
FP1007R6-R22-R	220	158		50.0	40.0		
FP1007R6-R27-R	270	194		41.0	33.0		
FP1007R6-R33-R	330	237		33.0	26.5		
FP1007R6-R39-R	390	280		28.0	22.5		
FP1007R6-R47-R	470	338		23.5	19.0		

- Open Circuit Inductance (OCL) Test Parameters: 100kHz, 0.10V<sub>rms</sub>, 0.0A<sub>dc</sub>
- Full Load Inductance (FLL) Test Parameters: 100kHz, 0.1V<sub>rms</sub>, I<sub>sat</sub>1
- I<sub>rms</sub>: DC current for an approximate temperature rise of 40°C without core loss. Derating is necessary for AC currents. PCB layout, trace thickness and width, air-flow, and proximity of other heat generating components will affect the temperature rise. It is recommended that the temperature of the part not exceed 125°C under worst case operating conditions verified in the end application.
- I<sub>sat</sub>1: Peak current for approximately 20% rolloff at +25°C.

- I<sub>sat</sub>2: Peak current for approximately 20% rolloff at +100°C.
- K-factor: Used to determine B<sub>p-p</sub> for core loss (see graph). B<sub>p-p</sub> = K \* L \* ΔI \* 10<sup>-3</sup>. B<sub>p-p</sub>:(Gauss), K: (K-factor from table), L: (Inductance in nH), ΔI (peak-to-peak ripple current in Amps).
- Part Number Definition: FP1007R6-Rxx-R  
FP1007R6 = Product code and size  
Rxx= Inductance value in uH, R = decimal point  
-R suffix = RoHS compliant

### Dimensions- mm

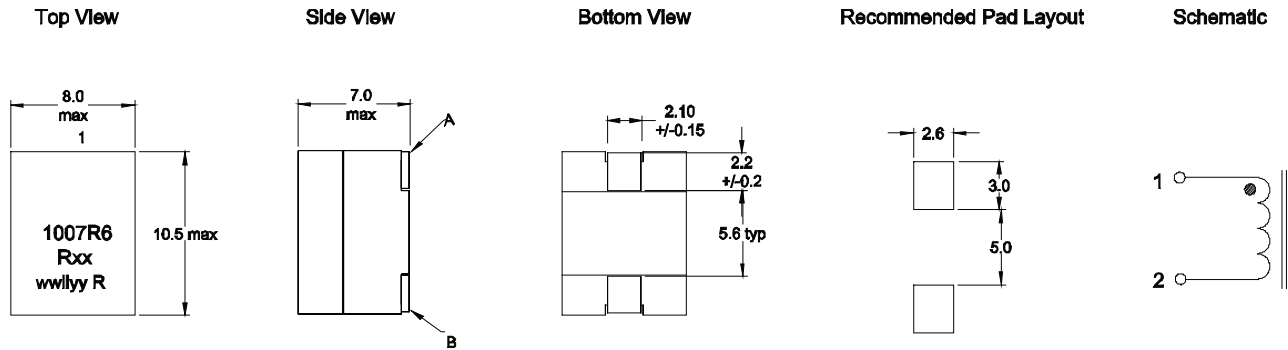

The nominal DCR is measured from point "A" to point "B"  
Part Marking: 1007R6, Rxx = Inductance value in μH. (R = Decimal point) wwlyy = Date code R = Revision level Tolerance are ±0.15mm unless otherwise specified.  
Soldering surfaces to be coplanar within 0.1016mm.  
PCB tolerance ±0.1mm unless otherwise specified.

### Packaging information - mm

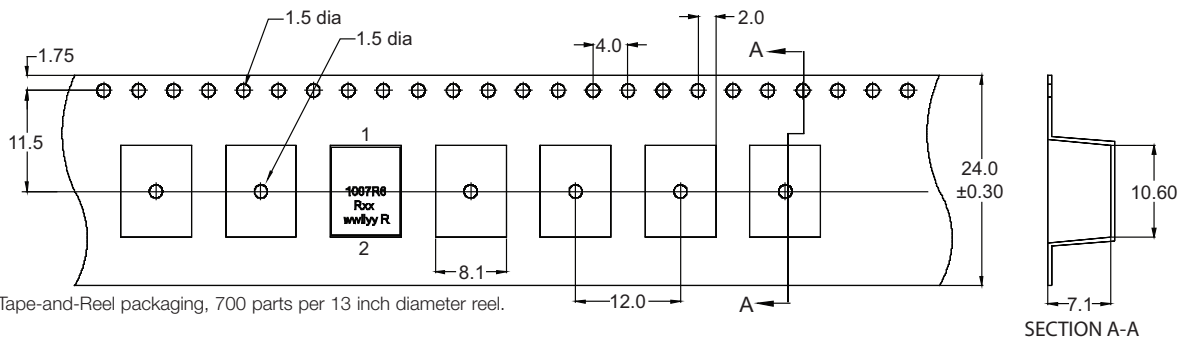

Supplied in Tape-and-Reel packaging, 700 parts per 13 inch diameter reel.

**Temperature rise vs total loss**



**Core loss vs Bp-p**



**Inductance characteristics**



**Solder Reflow Profile**



**Table 1 - Standard SnPb Solder ( $T_c$ )**

Package Thickness	Volume $\text{mm}^3$ <350	Volume $\text{mm}^3$ $\geq 350$
<2.5mm	235°C	220°C
$\geq 2.5\text{mm}$	220°C	220°C

**Table 2 - Lead (Pb) Free Solder ( $T_c$ )**

Package Thickness	Volume $\text{mm}^3$ <350	Volume $\text{mm}^3$ 350 - 2000	Volume $\text{mm}^3$ >2000
<1.6mm	260°C	260°C	260°C
1.6 – 2.5mm	260°C	250°C	245°C
>2.5mm	250°C	245°C	245°C

**Reference JDEC J-STD-020**

Profile Feature	Standard SnPb Solder	Lead (Pb) Free Solder
Preheat and Soak	• Temperature min. ( $T_{smin}$ )	100°C
	• Temperature max. ( $T_{smax}$ )	150°C
	• Time ( $T_{smin}$ to $T_{smax}$ ) ( $t_s$ )	60-120 Seconds
Average ramp up rate $T_{smax}$ to $T_p$	3°C/ Second Max.	3°C/ Second Max.
Liquidous temperature ( $T_L$ )	183°C	217°C
Time at liquidous ( $t_L$ )	60-150 Seconds	60-150 Seconds
Peak package body temperature ( $T_p$ )*	Table 1	Table 2
Time ( $t_p$ )** within 5 °C of the specified classification temperature ( $T_c$ )	20 Seconds**	30 Seconds**
Average ramp-down rate ( $T_p$ to $T_{smax}$ )	6°C/ Second Max.	6°C/ Second Max.
Time 25°C to Peak Temperature	6 Minutes Max.	8 Minutes Max.

\* Tolerance for peak profile temperature ( $T_p$ ) is defined as a supplier minimum and a user maximum.

\*\* Tolerance for time at peak profile temperature ( $t_p$ ) is defined as a supplier minimum and a user maximum.

Life Support Policy: Eaton does not authorize the use of any of its products for use in life support devices or systems without the express written approval of an officer of the Company. Life support systems are devices which support or sustain life, and whose failure to perform, when properly used in accordance with instructions for use provided in the labeling, can be reasonably expected to result in significant injury to the user.

Eaton reserves the right, without notice, to change design or construction of any products and to discontinue or limit distribution of any products. Eaton also reserves the right to change or update, without notice, any technical information contained in this bulletin.

**Eaton**  
Electronics Division  
1000 Eaton Boulevard  
Cleveland, OH 44122  
United States  
www.eaton.com/electronics

© 2017 Eaton  
All Rights Reserved  
Printed in USA  
Publication No. 10007 BU-SB12795  
June 2017



Eaton is a registered trademark.

All other trademarks are property of their respective owners.