

NOTES:

1. MATERIALS AND FINISHES:
 BODY, BUSHING BODY, HEX. NUT - BRASS, NICKEL PLATING (0.000100" THICK MIN)
 CONTACT - BERYLLIUM COPPER, GOLD PLATING (0.000004" THICK MIN)
 CONTACT PIN - BRASS, GOLD PLATING (0.000030" THICK MIN)
 FERRULE - BRASS, NICKEL PLATING (0.000100" THICK MIN)
 LOCKWASHER - PHOSPHOR BRONZE, SILVER PLATING (0.000200" THICK MIN)
 INSULATOR - PTFE, NATURAL
 GASKET - SILICONE RUBBER, BLACK
2. ELECTRICAL:
 A. IMPEDANCE: 50 OHM
 B. FREQUENCY RANGE: DC - 2.5 GHz
 C. VSWR: 1.15 MAX.
 D. DIELECTRIC WITHSTANDING VOLTAGE: 1500 VRMS, MIN.
3. MECHANICAL:
 A. CONNECTOR IS IP-67 COMPLIANT.
 B. DURABILITY: 500 CYCLES MIN.
 C. TEMPERATURE RANGE: -65° C TO 165° C
 D. THERE SHALL BE NO EVIDENCE OF AIR BUBBLES WHEN A 17 P.S.I. FORCE IS APPLIED TO MATING END WHILE WHOLE CONNECTOR IS IMMERSSED IN WATER.
4. PACKAGING:
 A. QUANTITY: SINGLE PACK
 B. MARKING: BAG TO BE MARKED "AMPHENOL, 82-6575, AND DATE CODE"
5. CABLE ASSEMBLY INSTRUCTIONS:
 A. TRIM CABLE AS SHOWN.
 B. SLIDE FERRULE & NUT-HEX ONTO CABLE
 C. CRIMP FERRULE USING .128" HEX. DIE.
 D. SLIDE THE INSULATOR DISC OVER THE CABLE CENTER CONDUCTOR.
 E. CRIMP OR SOLDER CONTACT PIN TO CABLE CENTER CONDUCTOR, FLARE CABLE BRAID, INSERT BODY-REAR, BRAID OVER BODY-REAR
 F. INSERT CABLE WITH CONTACT PIN, BODY-REAR INTO BODY
 G. APPLY THREAD LOCKING ADHESIVE ON THE THREADS OF THE NUT-HEX.
 H. TORQUE NUT-HEX DOWN TO 15 IN LB
 I. SHOWS CABLE ENTRY DIMENSIONS.

THIRD ANGLE PROJ.

REVISIONS

REV	DESCRIPTION	DATE	ECO	APPR
A	RELEASE TO MFG	05-Aug-13	49671	J.C

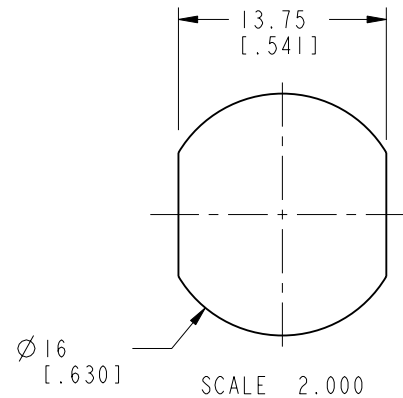

RECOMMENDED MOUTING HOLE DIMENSIONS

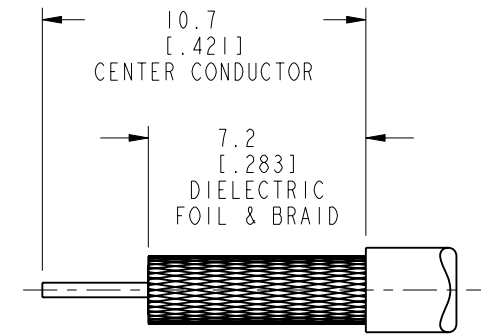

RECOMMENDED CABLE STRIPPING DIMENSIONS

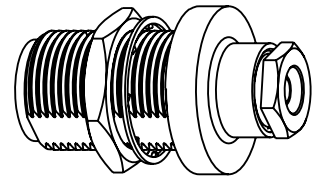

SCALE 1.000

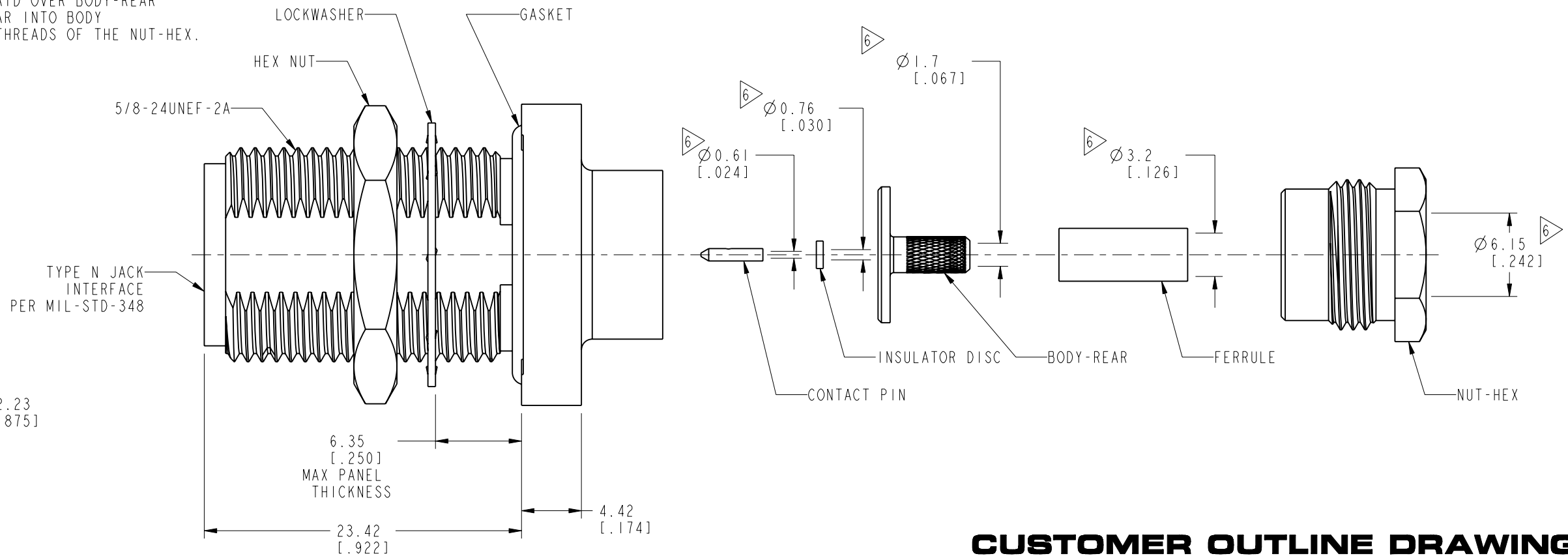
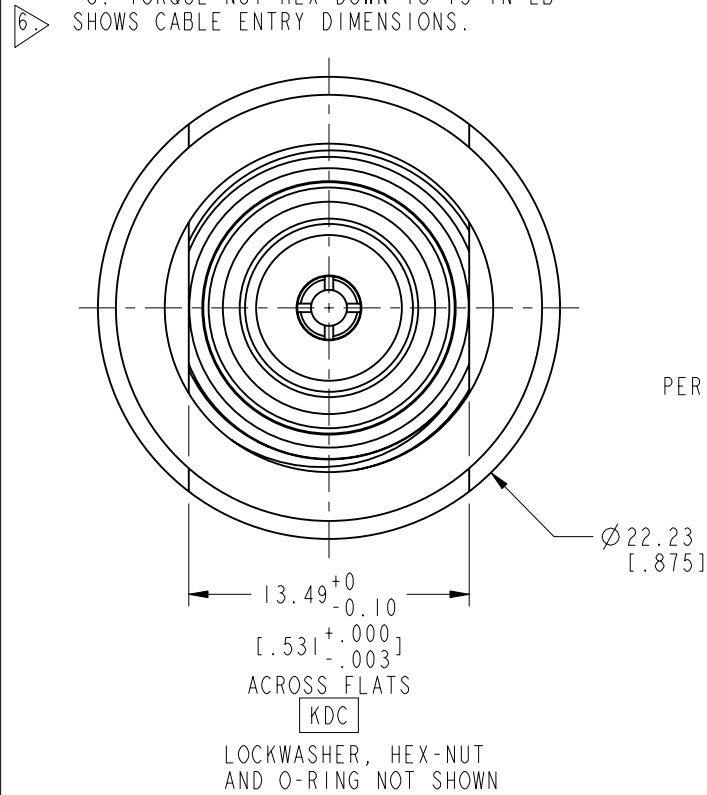

CUSTOMER OUTLINE DRAWING

ALL OTHER SHEETS ARE FOR INTERNAL USE ONLY

UNLESS OTHERWISE SPECIFIED, DIMENSIONS ARE IN METRIC AND TOLERANCES ARE:
 <0.5mm ±0.05mm 0.5 - 6mm ±0.1mm 6 - 30mm ±0.2mm 30 - 120mm ±0.3mm ANGLES ±1°

NOTICE - These drawings, specifications, or other data (1) are, and remain the property of Amphenol corp. (2) must be returned upon request; and (3) are confidential and not to be disclosed to any person other than those to whom they are given by Amphenol Corp. the furnishing of these drawings, specifications, or other data by Amphenol Corp., or to any other person to anyone for any purpose is not to be regarded by implication or otherwise in any manner licensing, granting rights to permitting such holder or any other person to manufacture, use or sell any product, process or design, patented or otherwise, that may in any way be related to or disclosed by said drawings, specifications, or other data.

MATERIAL	DRAWN J.CHEN	DATE 05-Aug-13	TITLE ASSEMBLY, N, IP-67 JACK, RG-316		Amphenol RF Danbury CT USA, Tainan, Taiwan, Shenzhen, China www.amphenolrf.com
REFERENCE EAR #3151 AND 82-6386	ENGINEER D.DAVE	DATE 10-Apr-13	SCALE: 2.8:1.0 SHEET 2 OF 2		
CONFIGURATION LEVEL: <input type="checkbox"/> <input type="checkbox"/> <input type="checkbox"/>	APPROVED S.HSIEH	DATE 06-Aug-13	DWG SIZE B	REV A	DRAWING NO.82-6575
FINISH					ITEM NO.82-6575
					PART NO.82-6575