



40 GHz SMA-2.9 N/O S.P.4 T. SWITCH

OPTIONS :

**R F CHARACTERISTICS**

NUMBER OF WAYS : 4  
 FREQUENCY RANGE : 0 - 40 GHz  
 IMPEDANCE : 50 Ohms

FREQUENCY (GHz)	0 - 6	6 -12.4	12.4- 18	18 -26.5	26.5- 40
V.S.W.R <=	1.30	1.40	1.50	1.70	2.20
INSERT. LOSS <=	0.20 dB	0.40 dB	0.50 dB	0.70 dB	1.10 dB
ISOLATION >=	70 dB	60 dB	60 dB	55 dB	50 dB
AVER. POWER (*)	40 W	30 W	25 W	15 W	5 W

**ELECTRICAL CHARACTERISTICS**

ACTUATOR : NORMALLY OPEN  
 NOMINAL CURRENT AT 25° C (±10%) : 250 mA  
 ACTUATOR VOLTAGE (Vcc) : 12V (10.2 to 13V) / POSITIVE COMMON  
 TERMINALS : solder pins (250°C max./30 sec.)

**MECHANICAL CHARACTERISTICS**

CONNECTORS : SMA 2.9 fem.per MIL C 39012  
 LIFE : 2.000.000 cycles per position  
 SWITCHING TIME (nominal voltage;25° C) : < 15 ms  
 CONSTRUCTION : splashproof  
 WEIGHT : < 180 g

**ENVIRONMENTAL CHARACTERISTICS**

OPERATING TEMPERATURE RANGE (°C) : -40 , +85  
 STORAGE TEMPERATURE RANGE (°C) : -55 , +85

(\* : average power at 25° C per RF path)

This information is given as an indication. In the continual goal to improve our products, we reserve the right to make any modifications judged necessary

4112-9212

4113-9212 This information is given as an indication. In the continual goal to improve our products, we reserve the right to make any modifications judged necessary

**DRAWING**

General tolerance: ± 0,5 mm

**R573 802.410**

Page  
2/2

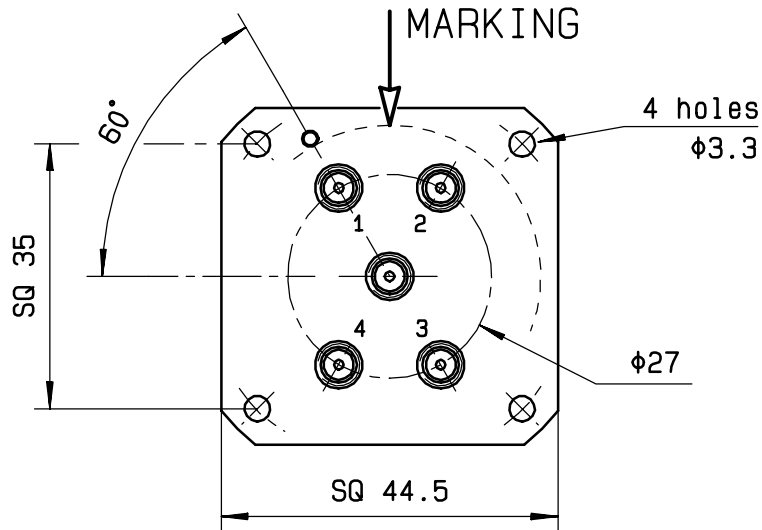

Voltage	RF continuity
+C -1	IN ↔ 1
+C -2	IN ↔ 2
+C -3	IN ↔ 3
+C -4	IN ↔ 4

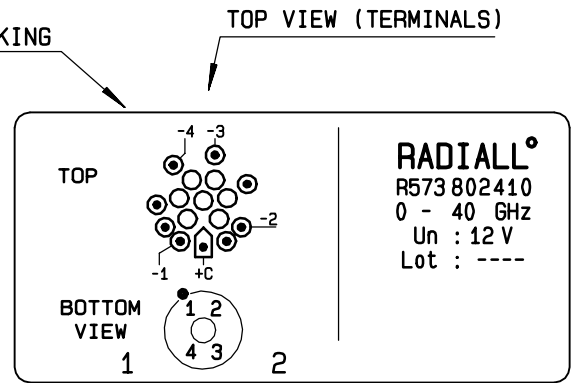
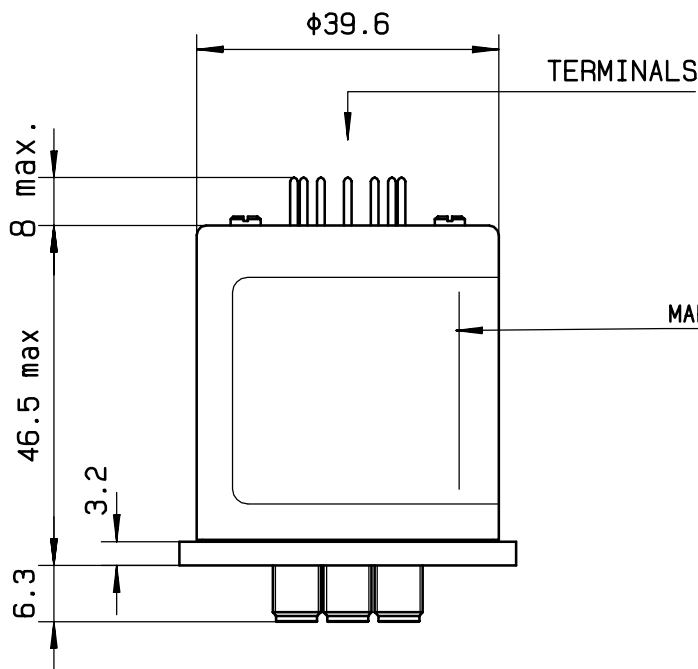

**SCHEMATIC DIAGRAM**

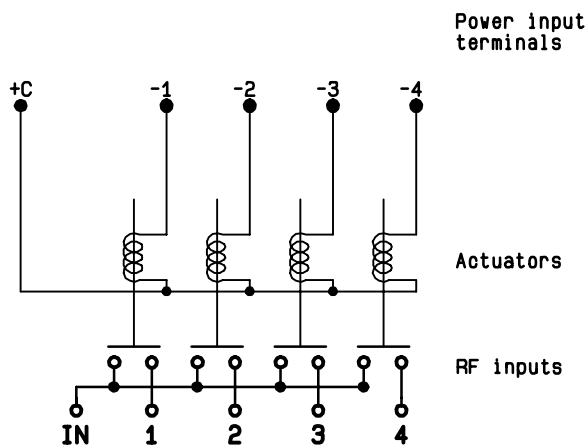

ISSUE 22. Jan. 08