

REVISION					
ZONE	LTR	ECN	DESCRIPTION	DATE	APPROVED
	A	33634	NEW RELEASE	8/22/91	<i>[Signature]</i>
	B	38154	DESCRIPTION WAS: MCK-**-P-21PST2	10/10/92	MLC
	C		UPDATE PER ECO-10-017486	8/25/10	PJS

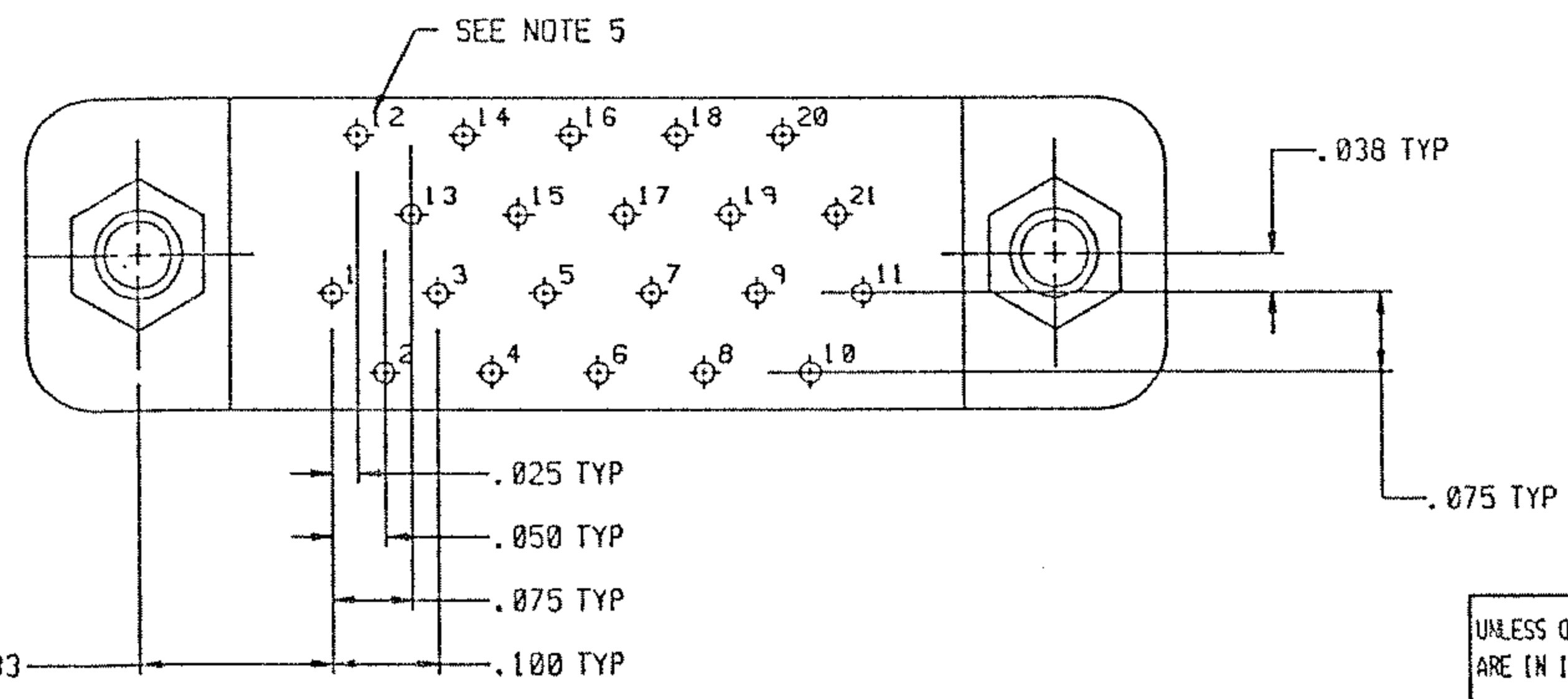
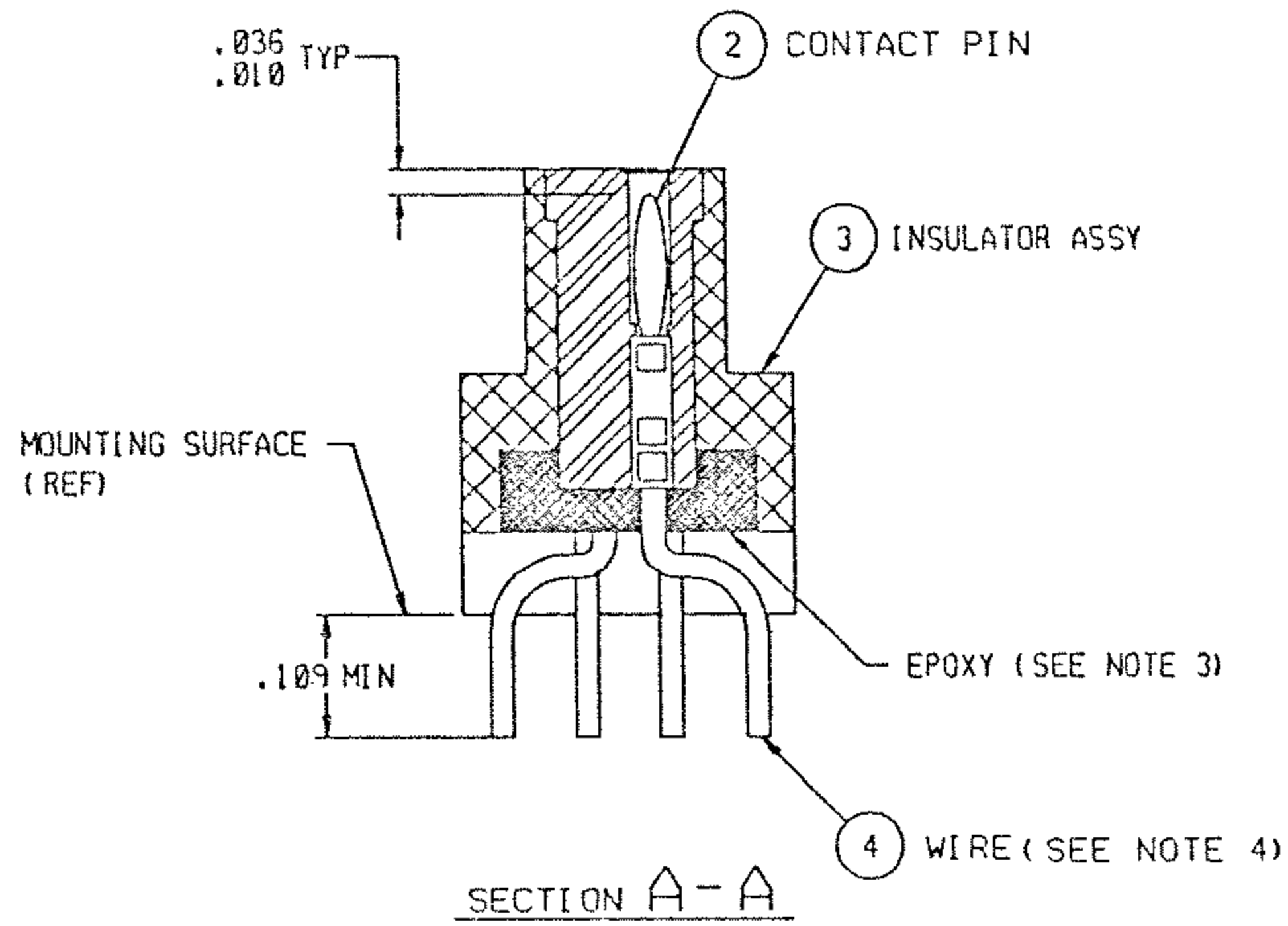
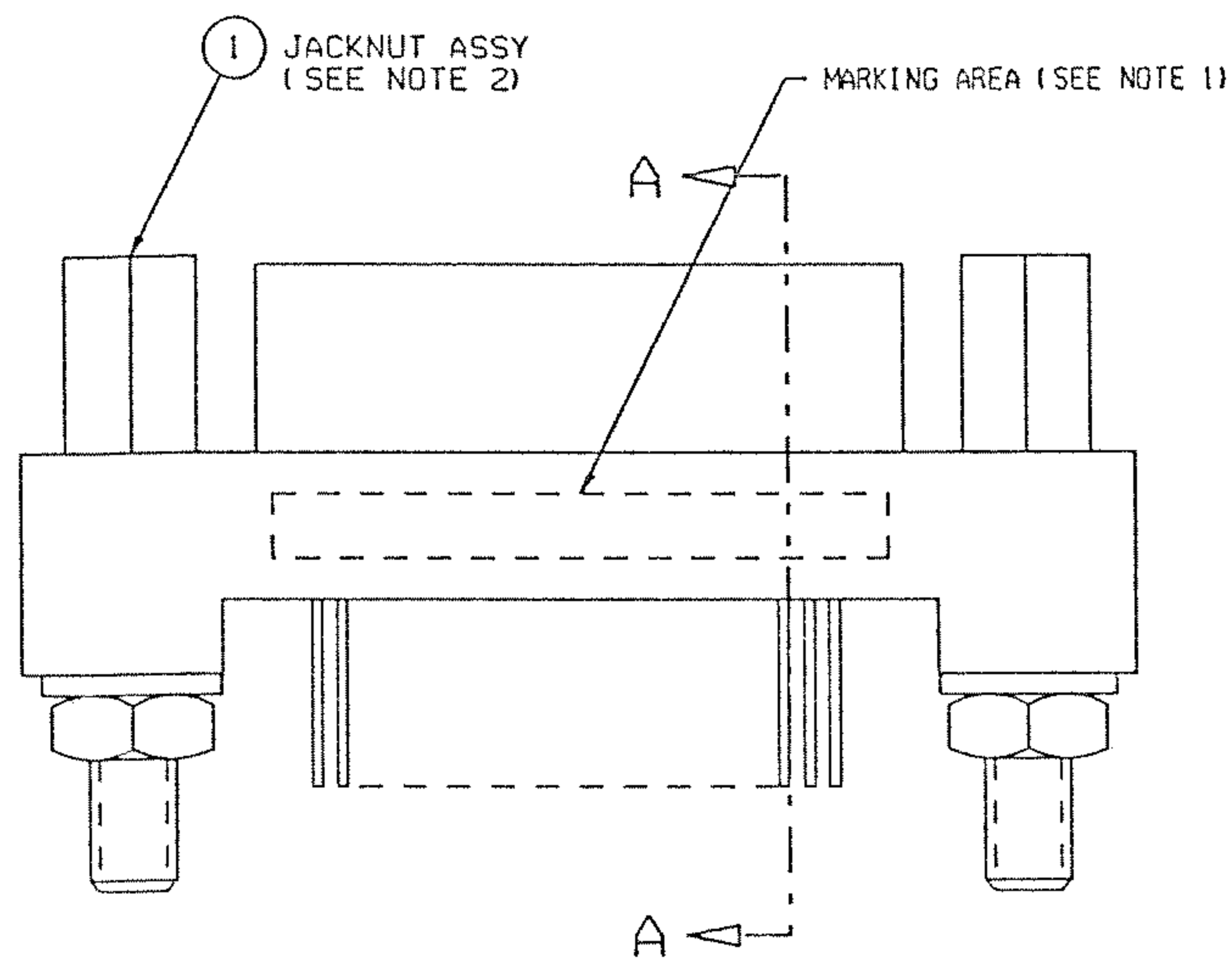
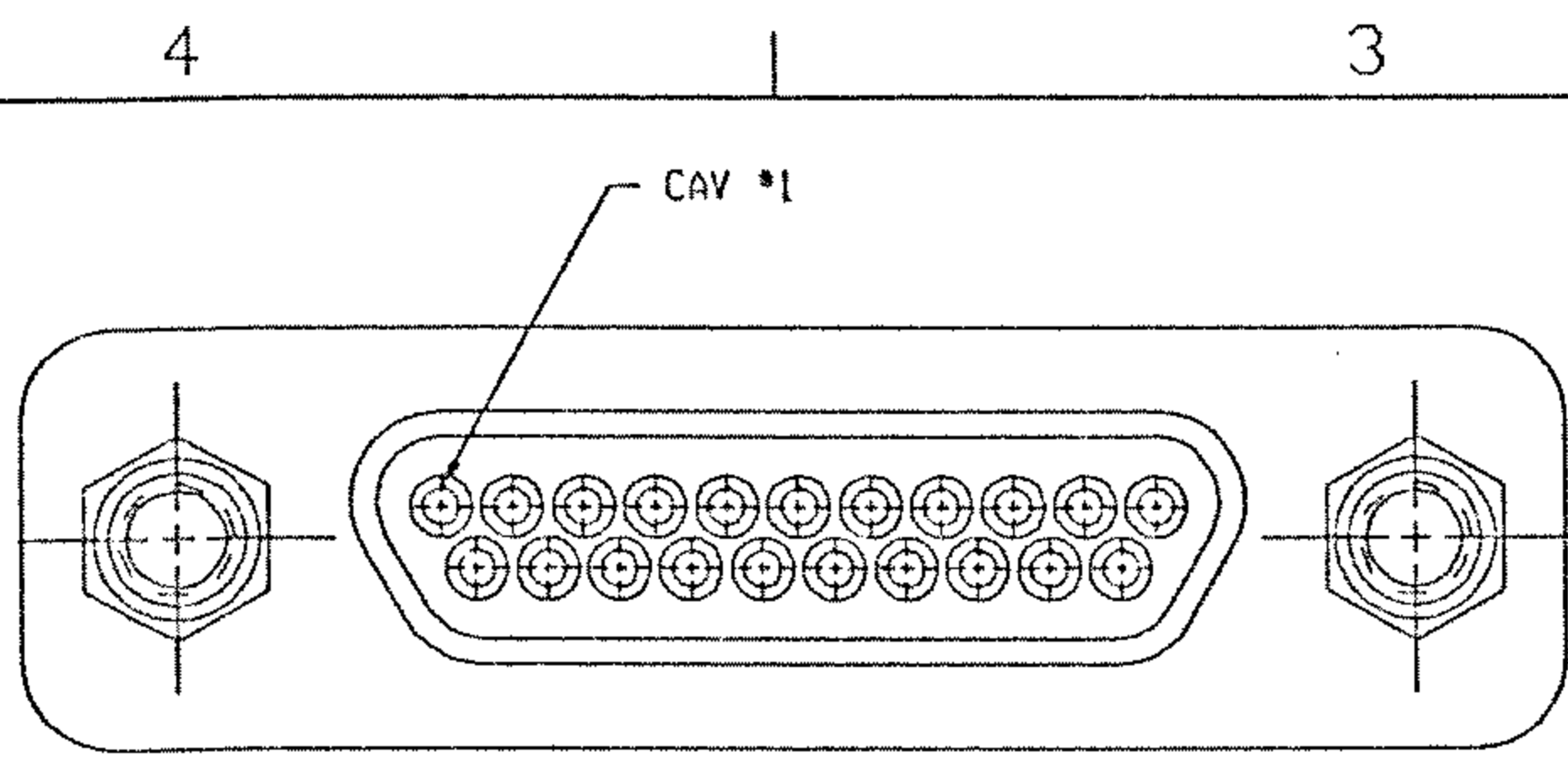

- NOTES: UNLESS OTHERWISE SPECIFIED
1. MARK PER MEP203-12
 2. ITEM 1, JACKNUT ASSEMBLIES AS SHOWN ARE ASSEMBLED ON FLANGE.
 3. EPOXY AS SHOWN. WICKING PERMITTED BEYOND POTTING WELL.
 4. TERMINAL WIRES ARE TO BE SOLDER DIPPED UP TO MOUNTING SURFACE (MINIMUM).
 5. LEAD IDENTIFICATION AS SHOWN ARE REFERENCE ONLY. DO NOT APPEAR ON THE PART.
 6. CRIMP LEADS INTO CONTACTS PER MEP302-05.

UNLESS OTHERWISE SPECIFIED DIMENSIONS ARE IN INCHES. TOLERANCE ARE: FRACTIONS DECIMALS ANGLES ± 1/8 .XX ± .01 ± 2° .XXX ± .005	APPROVALS		MALCO A MICRODOT COMPANY, INC. 306 PASADENA AVE., SO. PASADENA, CA 91030	PROD CODE 845 CODE M
	SIGNATURE	DATE		
MATERIAL:	DRAWN	<i>[Signature]</i>	METAL SHELL 'D' CONNECTOR, PLUG MCK-**-P-21PST2 180 DEGREE WITHOUT T.B. BLOCK 094-5304-7003	SIZE CODE IDENT NO. DRAWING NO. A 98278 7-1532223-4
	CHECKED			
FINISH:	PRO. ENG.	<i>[Signature]</i>	SCALE: NONE	SHEET 1 OF 1
	APPROVED			
THIS DOCUMENT IS THE PROPERTY OF MALCO, A MICRODOT CO. USE OF THIS DOCUMENT OR ANY PART OF THEREOF IS STRICTLY FORBIDDEN WITHOUT THE EXPRESS WRITTEN PERMISSION OF MALCO, A MICRODOT COMPANY.				