

207



»» Features

- Heavy duty sugar cube relay with 20A 120VAC, 16A 240VAC, TV-8 rating.
- UL & VDE safety approval.
- Optional for flux free, sealed type and sealed type washable cover, SPNO, SPDT contact configuration.
- High CTI 250 material or product comply with IEC 60335-1 are available.
- High performance PCB power relay for motor control, compressor control, home appliances.
- Complies with RoHS-Directive 2011/65/EU.
- Optional for halogen free version.

»» Type List

◆ Standard type

Terminal style	Contact form	Insulation system	Designation (provided with)		
			Flux tight	Sealed type	Sealed type washable
PCB terminal	1A (SPNO)	-----	207-1AH-C	207-1AH-V	207-1AH-S
		F	207-1AH-F-C	207-1AH-F-V	207-1AH-F-S

◆ High power type

PCB terminal	1A (SPNO)	-----	207H-1AC-C	207H-1AC-V	207H-1AC-S
		F	207H-1AC-F-C	207H-1AC-F-V	207H-1AC-F-S

»» Ordering Information

207 - 1A H - - C
 1 2 3 4 5 6 7 8

- | | |
|---|---|
| <p>1. 207 -- Basic series designation</p> <p>2. Blank -- Standard type
H -- High power type</p> <p>3. Blank -- Standard type
A -- Double pin type</p> <p>4. 1A -- Single pole normally open
1C -- Single pole double throw</p> <p>5. C -- Contact material AgNi
H -- Contact material AgSnO</p> | <p>6. Blank -- Standard type
F -- Class F</p> <p>7. C -- Flux tight
V -- Sealed type
S -- Sealed type washable</p> <p>8. <input type="checkbox"/> -- Coil voltage (please refer to the coil rating data for the availability)</p> |
|---|---|

»» Contact Rating

◆ 207

Resistive load	NO: 17A 240VAC 100K cycles 10A 240VAC at 105°C 300K cycles (B10 value) NC: 10A 240VAC 100K cycles
Max. switching current	20A
Max. switching voltage	277VAC
Max. switching capacity	4080VA

◆ 207H

Resistive load	NO: 17A 240VAC 100K cycles 16A 240VAC at 105°C 100K cycles 10A 240VAC at 105°C 300K cycles NC: 10A 240VAC 100K cycles
Max. switching current	20A
Max. switching voltage	277VAC
Max. switching capacity	4080VA

»» Coil Rating (DC)

Rated voltage (V)	Rated current ±10 % at 23°C (mA)	Coil resistance ±10 % at 23°C (Ω)	Max. continuous voltage at 85°C	Pick up voltage(Max.) at 23°C	Drop out voltage(Min.) at 23°C	Power consumption at rated voltage
3	130	23	150 % of rated voltage	75 % of rated voltage	5 % of rated voltage	approx. 0.4W
5	79	63				
6	67	90				
9	44	203				
12	33	360				
18	22	810				
24	17	1440				
36	11	3240				
48	8	5760				

»» Specification

Contact material	AgSnO / AgNi alloy	
Contact resistance ⁽¹⁾	100mΩ Max. (at 1A/6VDC by 4-wire resistance measurement)	
Operate time ⁽¹⁾	15ms Max.	
Release time ⁽¹⁾	10ms Max.	
Vibration resistance	Operating extremes	10~50Hz , amplitude 1.0 mm
	Damage limits	10~50Hz , amplitude 1.0 mm
Shock resistance	Operating extremes	10G
	Damage limits	100G
Life expectancy	Mechanical	10,000,000 ops. (frequency 18,000 ops./hr)
	Electrical	See contact rating. (frequency 360 ops./hr)
Operating ambient temperature	-40~+85°C (no freezing) ⁽²⁾	
Weight	Approx. 15 g	

Note : (1) Initial value. Operate and release time excluding contact bounce.

(2) special version of high temperature 105°C can be selected.

- (3) Unless otherwise specified, all tests are under room temperature and humidity.
- (4) Consider the heat of PCB is necessary, please check the actual condition of PCB.
- (5) Applying no diode to this relay. The life expectancy will be lower when a diode is used. To use a varistor (ZNR) could absorb the coil surge of relay that is recommended.
- (6) Do not use the relay exceeding the coil rating, contact rating and life expectancy, or this may cause the risk of overheating.
- (7) To assure optimum performance, avoid the relay from dropping, hitting, or other unnecessary shocks.
- (8) Do not switch the contacts without any load as the contact resistance may become increased rapidly.
- (9) Usage, transport and storage conditions
 - 1. Temperature: $-40 \sim +85^{\circ}\text{C}$
 - 2. Humidity: 5 to 85% R.H.
 - 3. Pressure: 86 to 106 kPa
 - Furthermore, the humidity range varies with the temperature. So, use relays within the range indicated in the graph below.

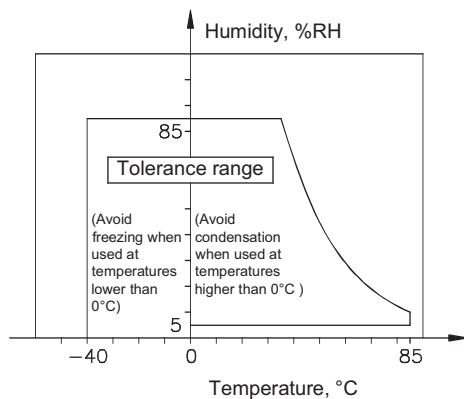

- (10) Please contact Song Chuan for the detailed information.

»» Insulation Data

Insulation resistance ⁽¹⁾	100 M Ω Min. (DC 500V)	
Dielectric strength ⁽¹⁾	Between open contact	: AC 1000V, 50/60Hz 1 min.
	Between contact and coil	: AC 2500V, 50/60Hz 1 min.
Insulation of IEC 61810-1		
Clearance / creepage distances	Between coil to contact	: Basic, $\geq 1.5\text{mm}$ / $\geq 2.5\text{mm}$
	Between open contact	: Functional
Rated insulation voltage	250V	
Rated impulse withstand voltage	2500V	
Pollution degree	2	
Rated voltage	230 / 400V	
Overvoltage category	II	

»» Safety Approval

Certified	UL / CUL	VDE
File No.	E88991	40025801

» Safety Approval Rating

UL / CUL				VDE
207		207H		
NO	NC	NO	NC	
20A 277VAC	16A 277VAC	20A 277VAC	16A 277VAC	NO : 17A 250VAC T105 NC : 10A 250VAC T85
1HP 125VAC	1/3HP 7.2A/125VAC	1HP 125VAC	1/3HP 7.2A/125VAC	
TV-5 (for AgSnO contact)	1/2HP 4.9A/250VAC 1/2HP 9.8A/125VAC (for AgSnO contact)	TV-8 (for AgSnO contact)	1/2HP 4.9A/250VAC 1/2HP 9.8A/125VAC (for AgSnO contact)	

Note : (1) Flux tight version is recommended in high temperature. If there is cleaning process and sealed type is selected, the vent-hole should be removed after the process.

» Outline Dimensions

◆ 207,207H

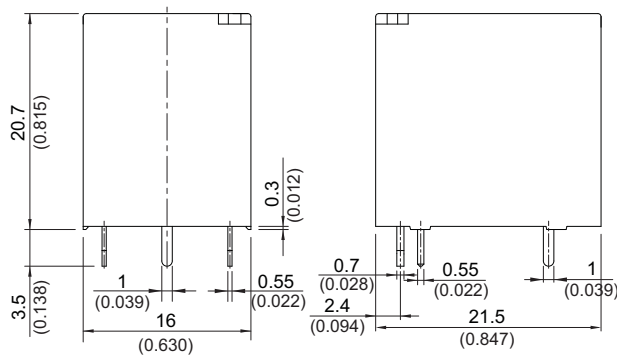

◆ 207A,207HA

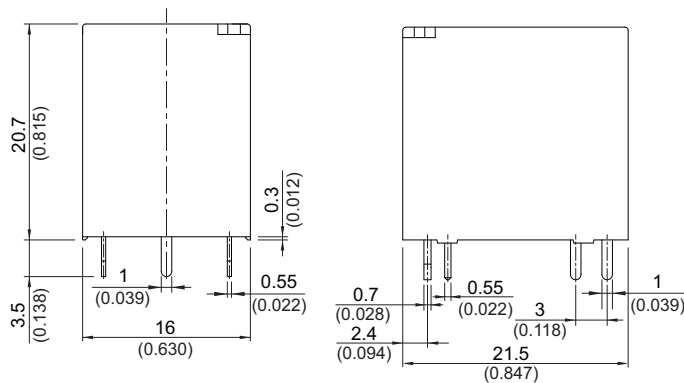

TOLERANCE:
 LESS THAN: 1(0.039) ±0.1(0.004)
 5(0.197) ±0.3(0.012)
 20(0.787) ±0.5(0.020)
 MORE THAN: 20(0.787) ±1(0.039)

» Wiring Diagram

BOTTOM VIEW

◆ 207,207H

1C

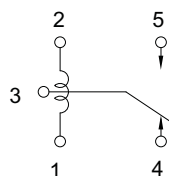

1A

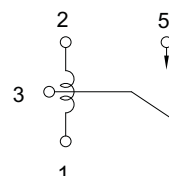

◆ 207A,207HA

1C

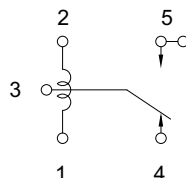

1A

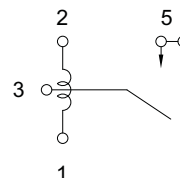

»» PC Board Layout

BOTTOM VIEW

◆ 207,207H

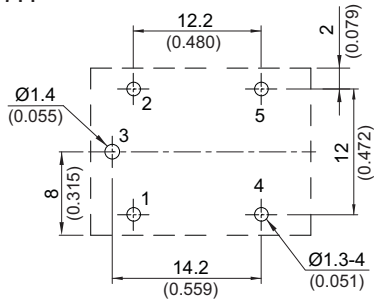

◆ 207A,207HA

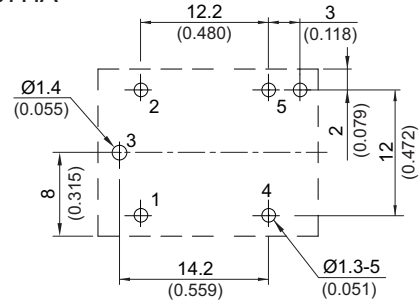

»» Engineering Data

Coil operating range

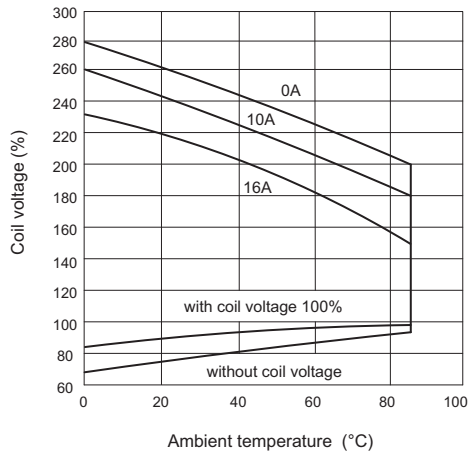

Coil temperature rise

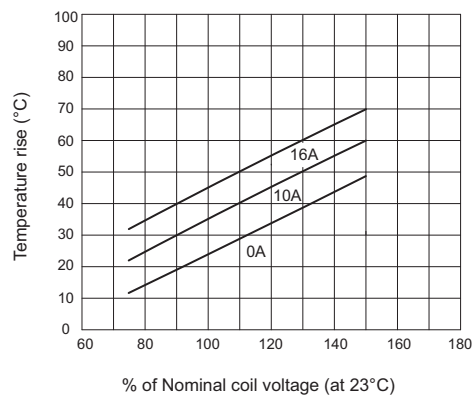

Coil temperature rise

