

AVERY DENNISON MARKETING SPECIFICATION

HISTORY

THE SUBJECT MATTER DISCLOSED HEREIN EMBODIES PROPRIETARY INFORMATION WHICH IS THE CONFIDENTIAL PROPERTY OF THE AVERY DENNISON CO. NONE OF WHICH SHALL BE COPIED, REPRODUCED, DISCLOSED TO OTHERS, PUBLISHED OR USED IN WHOLE OR IN PART, FOR ANY PURPOSE OTHER THAN THAT FOR WHICH IT IS BEING MADE AVAILABLE WITHOUT THE EXPRESS ADVANCE WRITTEN PERMISSION OF A DULY AUTHORIZED AGENT OF THE COMPANY. THIS DOCUMENT IS THE PROPERTY OF THE AVERY DENNISON CO. AND IS TO BE RETURNED TO THE COMPANY ON DEMAND.

REV.	DATE	DESCRIPTION
D	1.30.15	REDRAWN IN NEW FORMAT, ADDED UL INFORMATION AND LOGO
E	3.17.15	UPDATED DIM 5 TO BE 343.5mm TO MATCH NOMINAL MOLD DIM; UPDATED DIM 1 TO BE 7.3(TAKEN FROM THE BASE OF THE CABLE TIE HEAD)

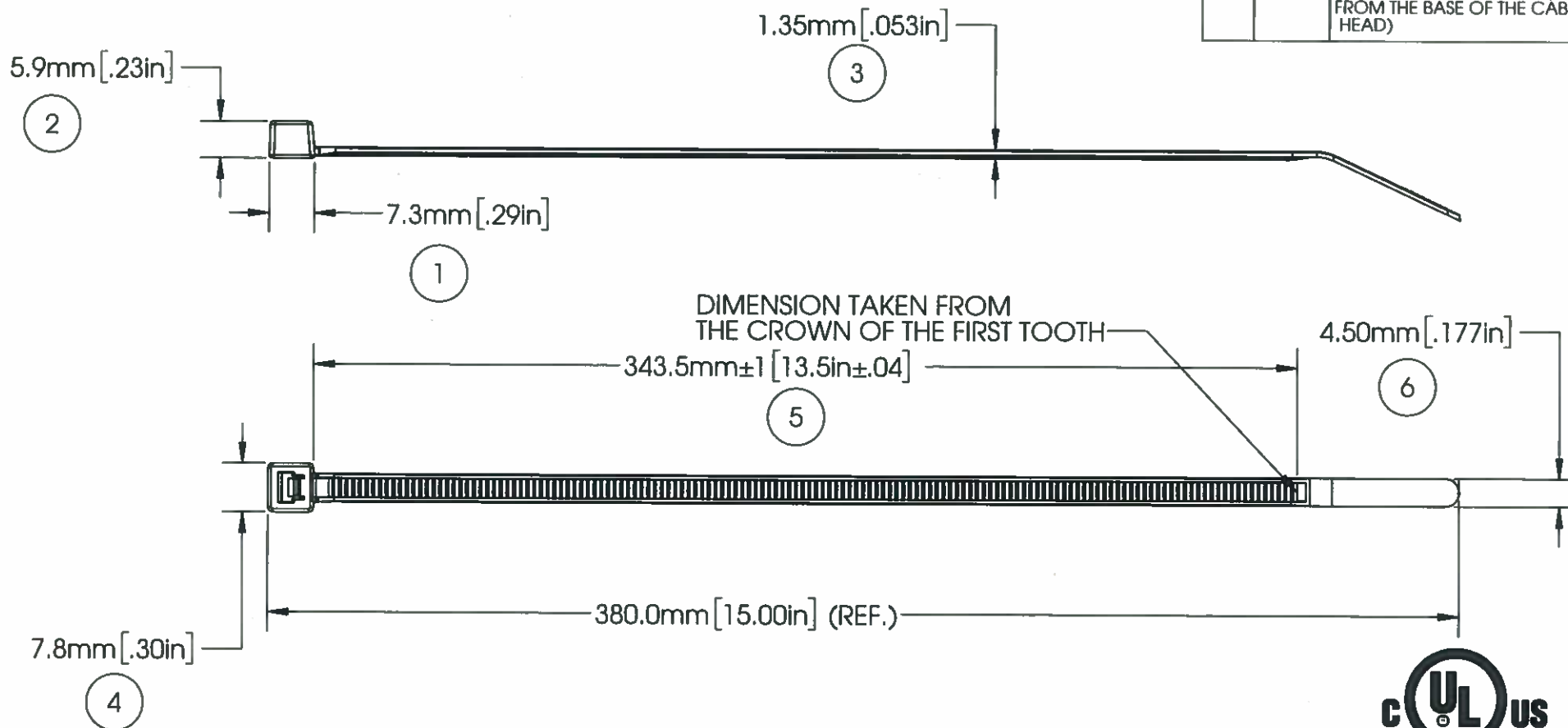

LISTED
POSITIONING DEVICE
E57800
TYPE 21

NOTE: THESE CABLE TIES ARE PLENUM RATED AND HAVE A FLAMMABILITY RATING OF V-2

LOOP TENSILE STRENGTH:	50 LBF/220 N MIN. PER AS-23190
OPERATING TEMP RANGE:	-40°F (-40°C) TO 221°F (105°C)
MIN. INSTALLATION TEMP:	32°F (0°C)
WEIGHT:	2.35 g. / (0.0800 oz)
BUNDLE DIAMETER:	∅ 1.6mm TO ∅ 101.6mm(0.06" -4")
TOOL:	12001-0 - HAND TOOL 12500-0 - PNEUMATIC TOOL
TOOL TENSION SETTING:	6-8
PACKAGING:	500/BAG, 5000/CASE

APPROVALS:	ENG. APPR. <i>[Signature]</i> 3/17/16
	Q.A. APPR. <i>[Signature]</i> 3/17/16



AVERY DENNISON

FASTENER DIVISION
FITCHBURG, MA 01420 U.S.A.
TEL: 1-800-226-5913
FAX: 978-353-8157

SPECIFIED TOLERANCES ARE:	
.XX ± .03 INCHES	.X ± .7 MM
.XXX ± .010 INCHES	.XX ± .25 MM
ANGULAR: ± 2°	

MATERIAL	NYLON 6/6
COLOR	BLACK HEAT STABILIZED

DESCRIPTION	15" CABLE TIE, STANDARD
STOCK NO.	10408-0
REV.	E

5 4 3 2 1