

### TYPE 1

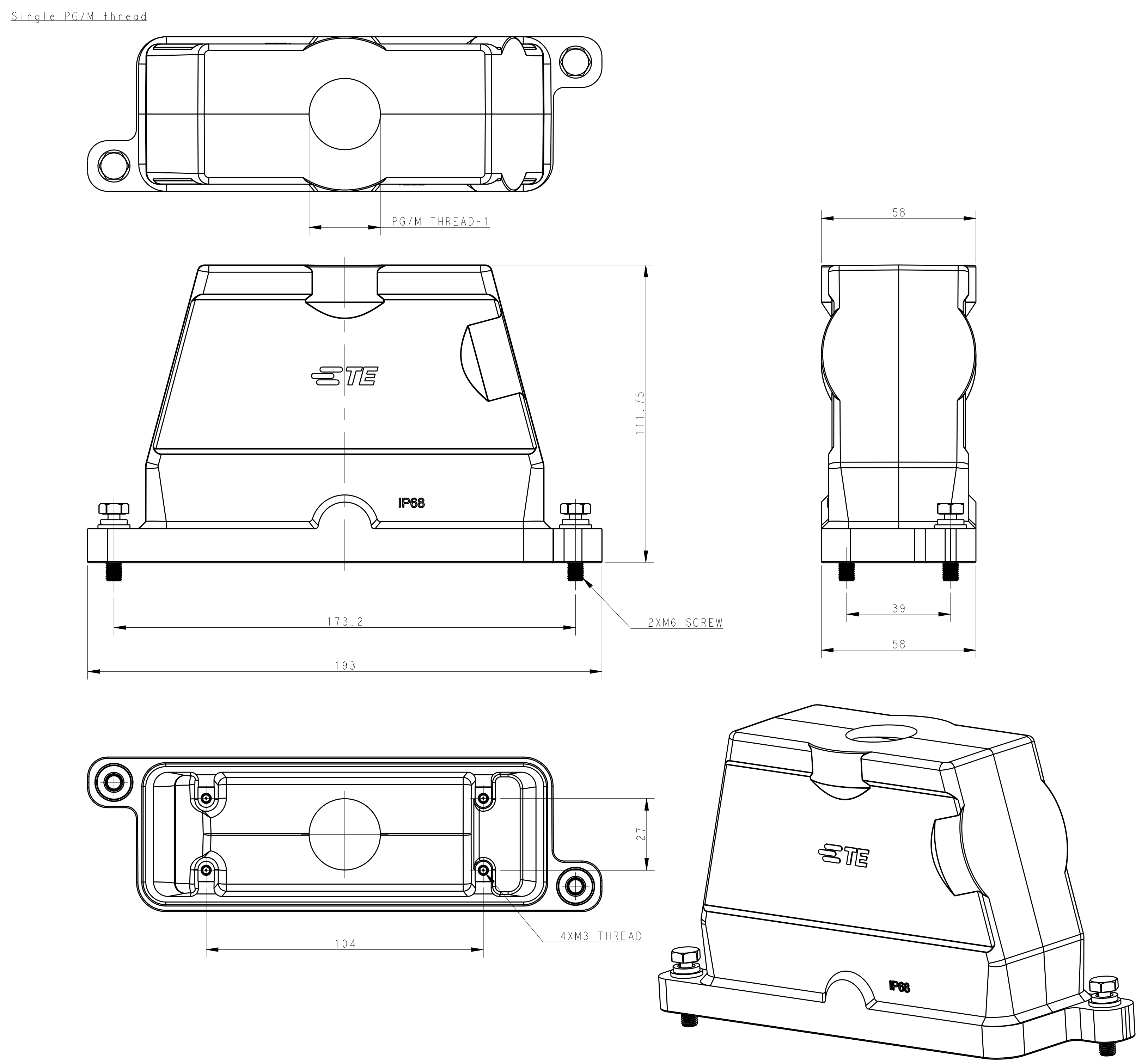

### TYPE 2

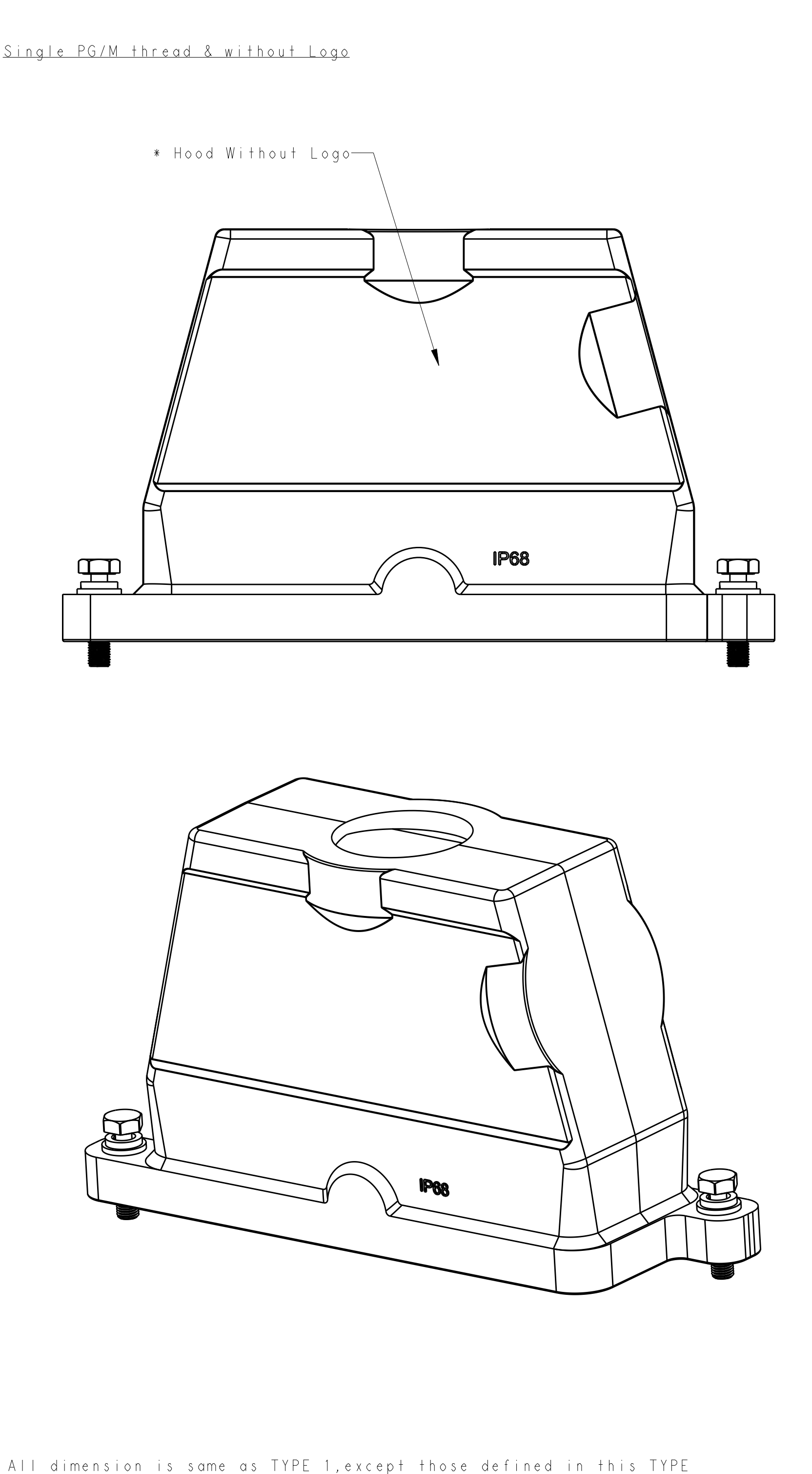

### TYPE 3

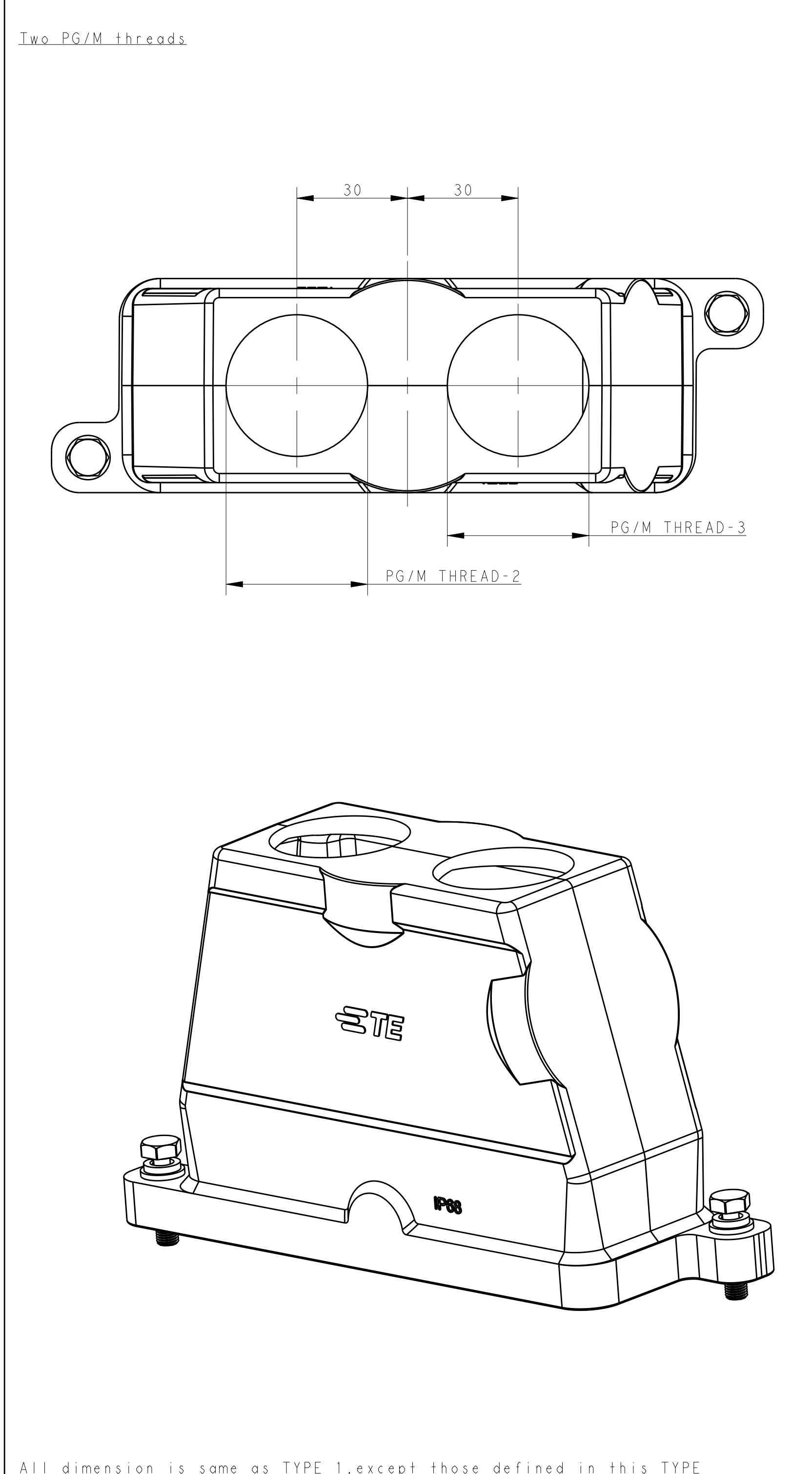

### TYPE 4

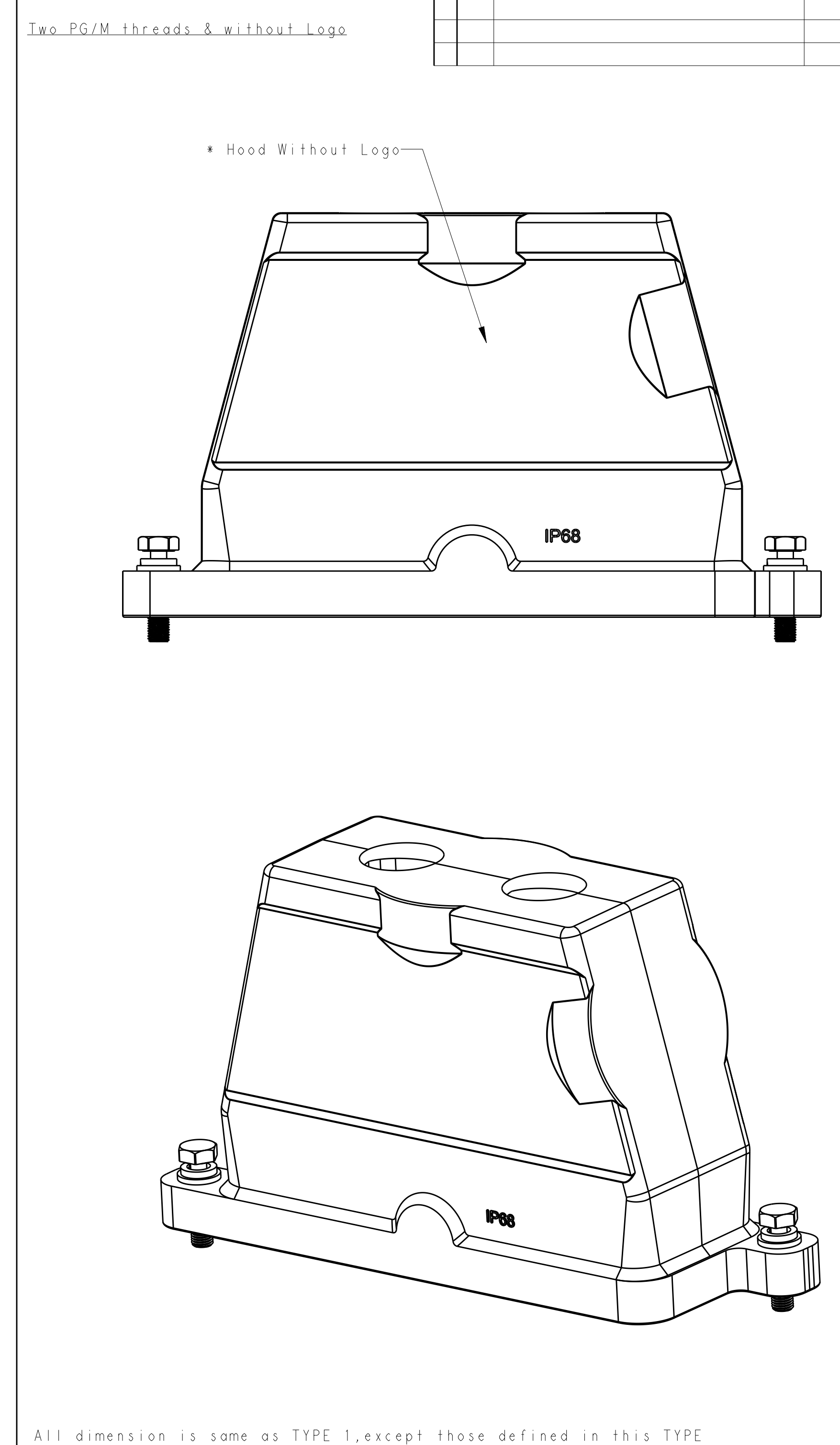

REVISIONS			
REV	DATE	BY	APPD
A	15JUN2015	GY	CW
DESCRIPTION			
INITIAL RELEASE			

### TYPE 5

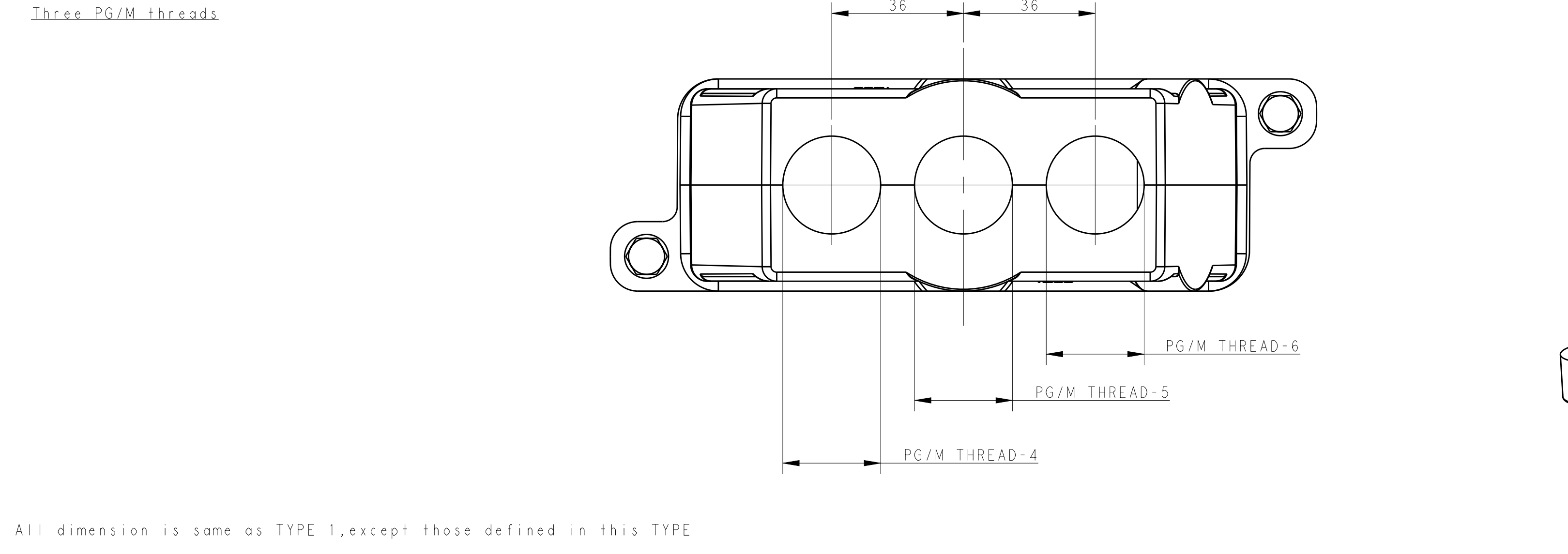

### TYPE 6

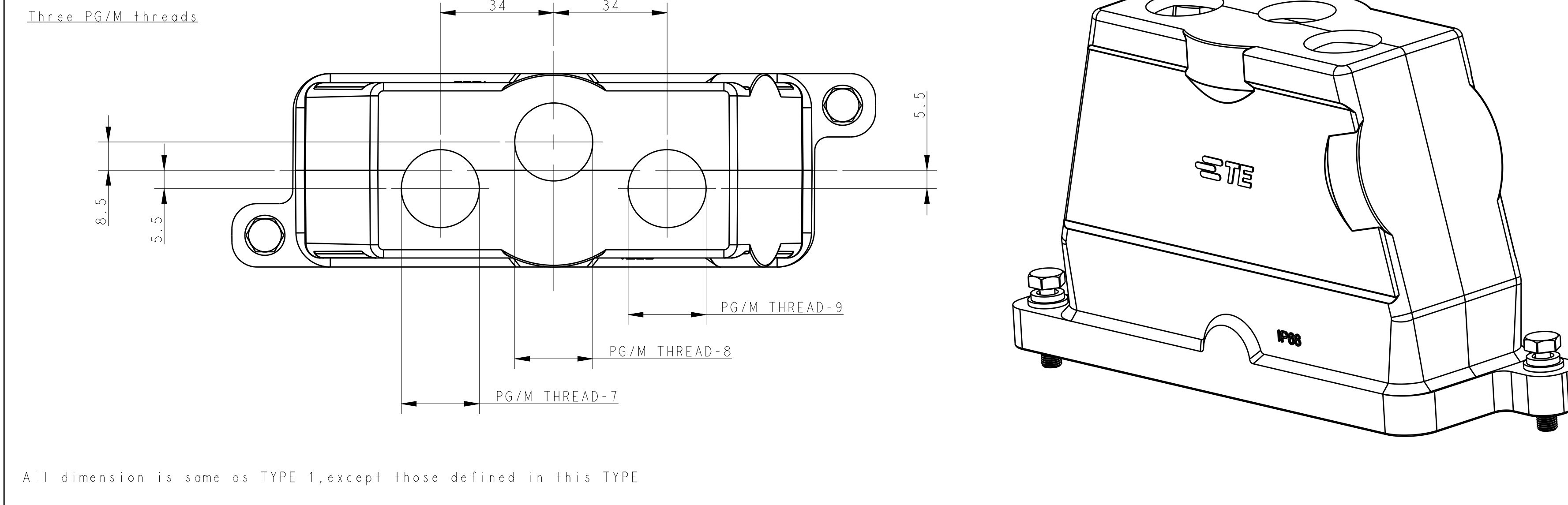

NOTES:  
 1. TECHNICAL CHARACTERISTICS:  
 HOOD MATERIAL: DIE CAST ALUMINIUM ALLOY  
 SURFACE TREATMENT: SEE TABLE  
 OPERATION TEMPERATURE: -40°C~+125°C  
 DEGREE OF PROTECTION: IP68 (MATED)

注:  
 1. 技术参数:  
 壳体材料: 铝合金  
 表面处理: 见表格  
 工作温度: -40°C~+125°C  
 防护等级: IP68 (配合)

PART NUMBER	SURFACE TREATMENT	DESCRIPTION	PG/M THREAD-9	PG/M THREAD-8	PG/M THREAD-7	PG/M THREAD-6	PG/M THREAD-5	PG/M THREAD-4	PG/M THREAD-3	PG/M THREAD-2	PG/M THREAD-1	TYPE
T1920240325-000	POWDER COATED BLACK	H24BPR-TGH-3M25	M25	M25	M25	-	-	-	-	-	-	TYPE 6
T1920240321-000	POWDER COATED BLACK	H24BPR-TGH-3PG21	-	-	-	PG21	PG21	PG21	-	-	-	TYPE 5
T1920240225-100	POWDER COATED BLACK	H24BPR-TGH-2M25	-	-	-	-	-	M25	M25	-	-	TYPE 4
T1920241232-000	POWDER COATED SILVER WHITE	H24BPR-TGH-2M32	-	-	-	-	-	M32	M32	-	-	TYPE 3
T1920240240-000	POWDER COATED BLACK	H24BPR-TGH-2M40	-	-	-	-	-	M40	M40	-	-	TYPE 2
T1920240140-100	POWDER COATED BLACK	H24BPR-TGH-M40	-	-	-	-	-	-	-	-	M40	TYPE 1
T1920241140-000	POWDER COATED SILVER WHITE	H24BPR-TGH-M40	-	-	-	-	-	-	-	-	M40	TYPE 1
T1920241136-000	POWDER COATED SILVER WHITE	H24BPR-TGH-PG36	-	-	-	-	-	-	-	-	PG36	TYPE 1
T1920241132-000	POWDER COATED SILVER WHITE	H24BPR-TGH-M32	-	-	-	-	-	-	-	-	M32	TYPE 1
T1920241129-000	POWDER COATED SILVER WHITE	H24BPR-TGH-PG29	-	-	-	-	-	-	-	-	PG29	TYPE 1
T1920241125-000	POWDER COATED SILVER WHITE	H24BPR-TGH-M25	-	-	-	-	-	-	-	-	M25	TYPE 1
T1920241121-000	POWDER COATED SILVER WHITE	H24BPR-TGH-PG21	-	-	-	-	-	-	-	-	PG21	TYPE 1
T1920240140-000	POWDER COATED BLACK	H24BPR-TGH-M40	-	-	-	-	-	-	-	-	M40	TYPE 1
T1920240136-000	POWDER COATED BLACK	H24BPR-TGH-PG36	-	-	-	-	-	-	-	-	PG36	TYPE 1
T1920240132-000	POWDER COATED BLACK	H24BPR-TGH-M32	-	-	-	-	-	-	-	-	M32	TYPE 1
T1920240129-000	POWDER COATED BLACK	H24BPR-TGH-PG29	-	-	-	-	-	-	-	-	PG29	TYPE 1
T1920240125-000	POWDER COATED BLACK	H24BPR-TGH-M25	-	-	-	-	-	-	-	-	M25	TYPE 1
T1920240121-000	POWDER COATED BLACK	H24BPR-TGH-PG21	-	-	-	-	-	-	-	-	PG21	TYPE 1

THIS DRAWING IS A CONTROLLED DOCUMENT.

DATE: 15JUN2015	REV: 0	BY: G.Luo_Yao	APPD: 15JUN2015
DATE: 15JUN2015	REV: 1	BY: C.H.Li_Wang	APPD: 15JUN2015
DATE: 15JUN2015	REV: 2	BY: Y.Luo_Yao	APPD: 15JUN2015

Customer Drawing

SCALE: 1:1