



Package: Laminate, 30-Pin, 3.2mm x 5.2mm x 1.09mm



Features

- 11a/n P_{OUT}= 17.5dBm at 3% EVM (5.1GHz to 5.85GHz)
- 11g and 11n: P_{OUT}= 19.5dBm at 2.5% EVM (2.4GHz to 2.484GHz)

Applications

- Cellular Handsets
- Mobile Devices
- Tablets
- Consumer Electronics
- Gaming
- Netbooks/Notebooks
- TV/Monitors/Video

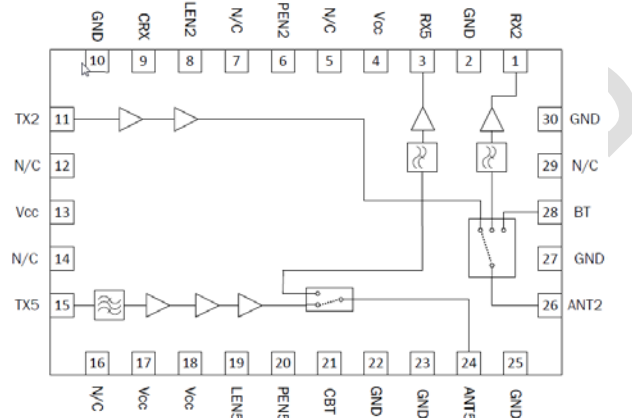

Functional Block Diagram

Product Description

The RFFM8800 provides a complete integrated solution in a single front end module (FEM) for 802.11b/g/a/n WiFi dual band systems. The ultra-small form factor and integrated matching minimizes the layout area in the customer's application and greatly reduces the number of external components. This simplifies the total front end solution by reducing the bill of materials, system footprint, and manufacturing cost. The RFFM8800 integrates a power amplifier (PA), single pole triple throw switch (SP3T), LNA for 2.412GHz to 2.484GHz and a power amplifier (PA), single pole double throw switch (SPDT), LNA for 4.9GHz to 5.85GHz. The device is provided in a 3.2mm x 5.2mm x 1.09mm, 30-pin laminate package. This module meets or exceeds the RF front end needs of IEEE 802.11b/g/a/n WiFi RF dual band systems.

Ordering Information

RFFM8800SB	Standard 5-piece sample bag
RFFM8800	Standard 25-piece sample bag
RFFM8800SR	Standard 100-piece reel
RFFM8800TR7	Standard 2500-piece reel
RFFM8800PCK-410	Fully assembled evaluation board with 5-piece bag

Absolute Maximum Ratings

Parameter	Rating	Unit
DC Supply Voltage	-0.5 to +5.4	Vdc
PA Enable Voltage	-0.5 to 5	Vdc
DC Supply Current	500	mA
Maximum Tx and Rx Input Power (no damage)	0	dBm
Operating Case Temperature	-40 to +85	°C
Storage Temperature	-40 to +150	°C
Moisture Sensitivity	MSL3	



Caution! ESD sensitive device.

Exceeding any one or a combination of the Absolute Maximum Rating conditions may cause permanent damage to the device. Extended application of Absolute Maximum Rating conditions to the device may reduce device reliability. Specified typical performance or functional operation of the device under Absolute Maximum Rating conditions is not implied.

RoHS status based on EUDirective2002/95/EC (at time of this document revision).

The information in this publication is believed to be accurate and reliable. However, no responsibility is assumed by RF Micro Devices, Inc. ("RFMD") for its use, nor for any infringement of patents, or other rights of third parties, resulting from its use. No license is granted by implication or otherwise under any patent or patent rights of RFMD. RFMD reserves the right to change component circuitry, recommended application circuitry and specifications at any time without prior notice.

Parameter	Specification			Unit	Condition
	Min.	Typ.	Max.		
Input and Output Port Impedance		50		Ω	
Operating Temperature	-10		+70	°C	
Extended Operating Temperature	-40		+85	°C	Functional with derated performance
Storage Temperature	-40		+150	°C	
Power Supply V _{cc}	3	3.3	4.8	V	
Switch Control Voltage - high	2.8	3.1	4.6	V	
Switch Control Voltage - low		0	0.2	V	
PEN2, PEN5 ON	2.8	3.1	4.6	V	PA in "On" state
PEN2, PEN5 OFF		0	0.2	V	PA in "Off" state
Transmit (TX-ANT) 802.11b/g/n					T= 25 °C; V _{cc} = 3.3V, PEN2=High; 50% Duty Cycle; Freq= 2.412GHz to 2.484GHz unless otherwise noted.
EVM					
Frequency Range	2.412		2.484	GHz	
11g		1.7	2	%	18.0dBm
		2.5	3	%	19.5dBm
11n			2	%	17.5dBm
		2.5	3	%	18.5dBm
Gain (2.142GHz to 2.484GHz)	21	24	26.5	dB	At rated P _{OUT}
Gain Variance slope					
Channel 40MHz BW	-1		1	dB	
Channel 20MHz BW	-0.5		0.5	dB	
Frequency 100MHz BW	-2		2	dB	50Ω load
Out of Band Gain (1600MHz to 1660MHz)			-12	dBc	
11b Spectral Mask		-34	-32	dBc	At P _{OUT} = 21.5dBm:fc +/-11MHz
		-54	-52	dBc	At P _{OUT} = 21.5dBm:fc +/-22MHz
11g Spectral Mask		-23	-20	dBc	At P _{OUT} = 19.5dBm:fc +/-11MHz
		-30	-25	dBc	At P _{OUT} = 19.5dBm:fc +/-20MHz
		-43	-40	dBc	At P _{OUT} = 19.5dBm:fc +/-30MHz
11n Spectral Mask		-23	-20	dBc	At P _{OUT} = 18.0dBm:fc +/-11MHz
		-30	-28	dBc	At P _{OUT} = 18.0dBm:fc +/-20MHz
		-48	-45	dBc	At P _{OUT} = 18.0dBm:fc +/-30MHz
Current Consumption					
Quiescent		140		mA	
Operating		190	230	mA	P _{out} = 19.5dBm, 11g
FEM Leakage		5		μA	V _{cc} = 4.8V, RF= "OFF"
TX Port Return Loss (S11)		-12	-8	dB	
ANT Port Return Loss		-12		dB	
Harmonics					P _{OUT} = 21.5dBm, 1Mbps, DSSS BW= 1MHz, up to 3:1 load
Second		-25	-22	dBm	4.80GHz to 5.00GHz, V _{cc} = 3.3V
Third		-40		dBm	7.20GHz to 7.50GHz, V _{cc} = 3.3V
Stability					PA must be stable from 0dBm to 21dBm. CW Signal, No spurs above -41.25dBm for non-harmonic related signals
Output VSWR	4:1				All phase angles, no spurious or oscillations
Turn-On/Off Time		0.2	0.8	μA	From 10% to 90% of total gain/ From 90% to 10% of power-off gain

2.4 GHz to 2.5GHz and 4.9GHz to 5.85GHz 802.11b/g/a/n Front End module

Receive (ANT-RX) 802.11b/g/n					T= 25 °C; V _{CC} = 3.3V, LEN2=High, CRX=High; 50% Duty Cycle; Freq= 2.412GHz to 2.484GHz unless otherwise noted
LNA Voltage Supply (LNA V _{CC})	3	3.3	4.8	V	
Gain Mode					
Gain Variation		0.25	0.4	dB	Over any 40MHz band
Gain	10	12	15	dB	
NF		2	2.5	dB	
Rx Port Return Loss		-10	-6	dB	
ANT Port Return Loss		-8	-5	dB	
Input IP3		2		dBm	
Input P1dB	-10	-5		dBm	
I _{DD}		10	13	mA	
LEN2 Control Current		60	120	µA	
Bluetooth					T= 25 °C; V _{CC} = 3.3V, CBT=High; 50% Duty Cycle; Freq= 2.412GHz to 2.484GHz unless otherwise noted
Input/Output Power	20			dBm	
Insertion Loss	-0.9	-0.7		dB	
BT Port Return Loss		-19	-15	dB	
ANT Port Return Loss		-19	-15	dB	
Isolation					
ANT-BT; Tx Mode		18		dB	
ANT-BT; Rx Gain Mode		21		dB	
Ant-RX; Tx Mode		35		dB	
ANT-RX; BT Mode		35		dB	
Transmit (TX-ANT) 802.11a/n					T= 25 °C; V _{CC} = 3.3V, PEN5=High; 50% Duty Cycle; Freq= 5.15GHz to 5.85GHz unless otherwise noted
Frequency	5.15		5.85	GHz	
Extended Frequency	4.9		5.15	GHz	Functional with derated performance Into 50Ω
Maximum Input Power			+5	dBm	
Gain (5.15GHz to 5.85GHz)- Nominal	25.5	28	31	dB	P _{OUT} = 17.5dBm
EVM (5.15GHz to 5.85GHz)- Nominal		2.9	3.2	%	P _{OUT} = 17.5dBm
Quiescent Current- Nominal		150		mA	RF off
Operating Current- Nominal		215	260	mA	P _{OUT} = 17.5dBm
Second Harmonic- Nominal		-24	-20	dBm	RF P _{OUT} =17.5dBm; Measured in 1MHz resolution bandwidth
Third Harmonic- Nominal		-45	-40	dBm	RF P _{OUT} =17.5dBm; Measured in 1MHz resolution bandwidth
ACP1.1a Spectral Mask		-23	-20	dBc	At P _{OUT} = 17.5dBm: fc +/-11MHz
		-30	-28	dBc	At P _{OUT} = 17.5dBm: fc +/-20MHz
		-43	-40	dBc	At P _{OUT} = 17.5dBm: fc +/-30MHz
ACP1.1n Spectral Mask		-23	-20	dBc	At P _{OUT} = 16dBm: fc +/-11MHz
		-30	-28	dBc	At P _{OUT} = 16dBm: fc +/-20MHz
		-43	-40	dBc	At P _{OUT} = 16dBm: fc +/-30MHz
Tx Port Return Loss		-10	-5	dB	TXA-ANT SPAR RF= TXA CW; PI= -30
ANT Port Return Loss		-20	-15	dB	
PA Switching Time - V _{ref} (on->off)		0.2	1	µs	
PA Stability					Unconditional into 4:1 VSWR, No spurious above- 41.25dBm/MHz
Receive (ANT-RX) 5GHz					T= 25 °C; V _{CC} = 3.3V, LEN5=High, CRX=High; 50% Duty Cycle; Freq= 5.15GHz to 5.85GHz unless otherwise noted
LNA Voltage Supply (LNA V _{CC})	3	3.3	4.8	V	
Gain	11	14	17	dB	
NF		2.5	3.5	dB	
Rx Port Return Loss		-9		dB	
ANT Port Return Loss		-9		dB	
Input IP3		-5		dB	
Input P1dB	-20	-15		dBm	
I _{DD}		10	15	mA	
LEN5 Control Current		2		µA	
LNA Turn On Time			0.8	µs	
Out of Band Gain		7		dB	800MHz to 1900MHz

General Specifications					
Control Current					
CRX, CBT		5		μA	
Switch Control Speed			100	ns	
ESD					
Human Body Model	500			V	EIA/JESD22-114A RF pins
	1000			V	EIA/JESD22-114A DC pins
Charge Device Model	500			V	JESD22-C101C all pins
RF Port Impedance		50		Ω	TX, RX, BT, ANT ports

Operating Modes							
Mode #	Mode Description	PEN2	LEN2	PEN5	LEN5	CRX	CBT
0	All Off	0	0	0	0	0	0
1	BT	0	0	0	0	0	1
2	BT + RX5	0	0	0	1	1	1
3	BT+ TX5	0	0	1	0	0	1
4	TX2	1	0	0	0	0	0
5	RX2	0	1	0	0	1	0
6	TX5	0	0	1	0	0	0
7	RX5	0	0	0	1	1	0
8	RX2 + RX5	0	1	0	1	1	0

CONFIDENTIAL: NDA REQUIRED

2.4 GHz to 2.5GHz and 4.9GHz to 5.85GHz 802.11b/g/a/n Front End module

Pin	Function	Description
1	RX2	2.4GHz Receive (Rx) 50Ω output pin.
2	GND	Ground.
3	RX5	5GHz Receive (Rx) 50Ω output pin.
4	VCC	Supply voltage for the 2GHz PA output stage and LNA. See applications schematic for biasing and bypassing components.
5	N/C	No Connect. This pin is not connected internally. It can be left floating or connected to ground.
6	PEN2	Enable for 2.4GHz PA and Tx switch.
7	N/C	No Connect. This pin is not connected internally. It can be left floating or connected to ground.
8	LEN2	Enable for 2.4GHz LNA and Rx switch.
9	CRX	Switch Control for Rx Switches. High control voltage turns on the Rx path (see switch logic tables).
10	GND	Ground.
11	TX2	RF input port for the 802.11b/g/n PA. Input is matched to 50. Internally DC blocked.
12	N/C	No Connect. This pin is not connected internally. It can be left floating or connected to ground.
13	VCC	Supply voltage for the 2GHz PA driver stage and LNA. See applications schematic for biasing and bypassing components.
14	N/C	No Connect. This pin is not connected internally. It can be left floating or connected to ground.
15	TX5	RF input port for the 802.11a/n PA. Input is matched to 50Ω. Internally DC blocked.
16	N/C	No Connect. This pin is not connected internally. It can be left floating or connected to ground.
17	VCC	Supply voltage for the 2GHz PA driver stage and LNA. See applications schematic for biasing and bypassing components.
18	VCC	Supply voltage for the 2GHz PA output stage and LNA. See applications schematic for biasing and bypassing components.
19	LEN5	Enable for 5GHz LNA and Rx switch.
20	PEN5	Enable for 5GHz PA and Tx switch.
21	CBT	Switch control for BT. High control voltage turns on the BT path (see switch logic tables).
22	GND	Ground.
23	GND	Ground.
24	ANT5	RF bidirectional 5GHz antenna port matched to 50Ω.
25	GND	Ground.
26	ANT2	RF bidirectional 2.4GHz antenna port matched to 50Ω.
27	GND	Ground.
28	BT	BT Port 50Ω input/output pin.
29	N/C	No Connect. This pin is not connected internally. It can be left floating or connected to ground.
30	GND	Ground.
Pkg Base	GND	Ground connection. The backside of the package should be connected to the ground plane through a short path, PCB vias under the device are recommended.

Detailed Functional Block Diagram

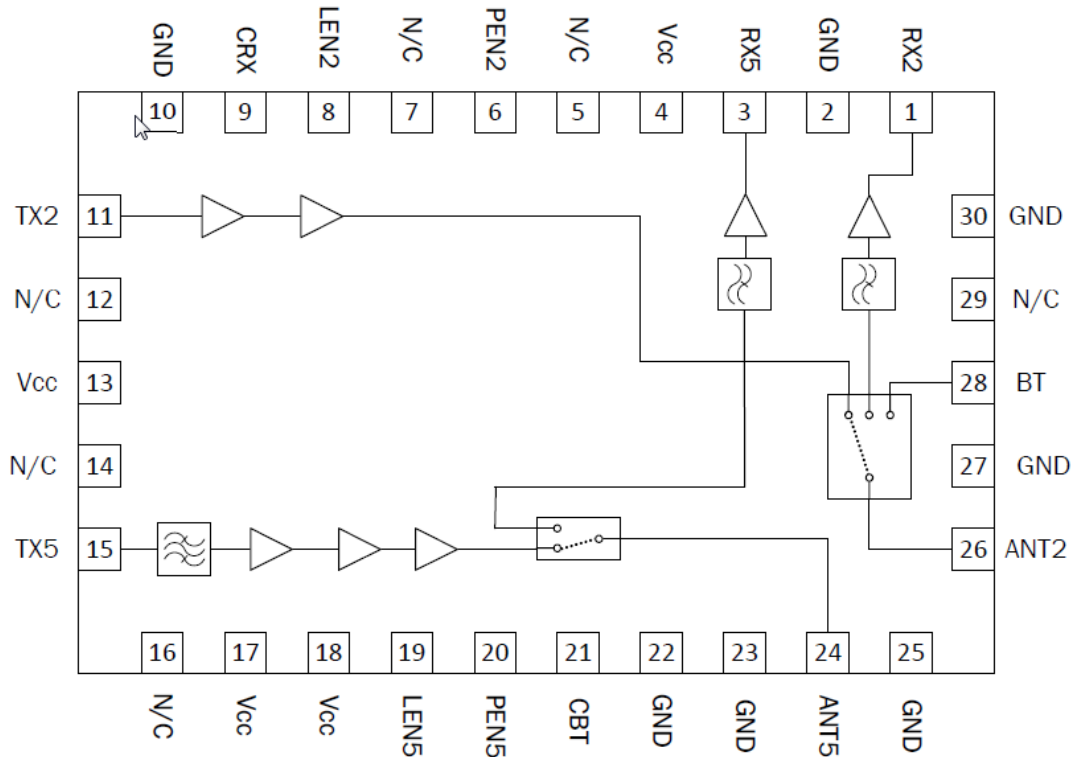

Package Drawing

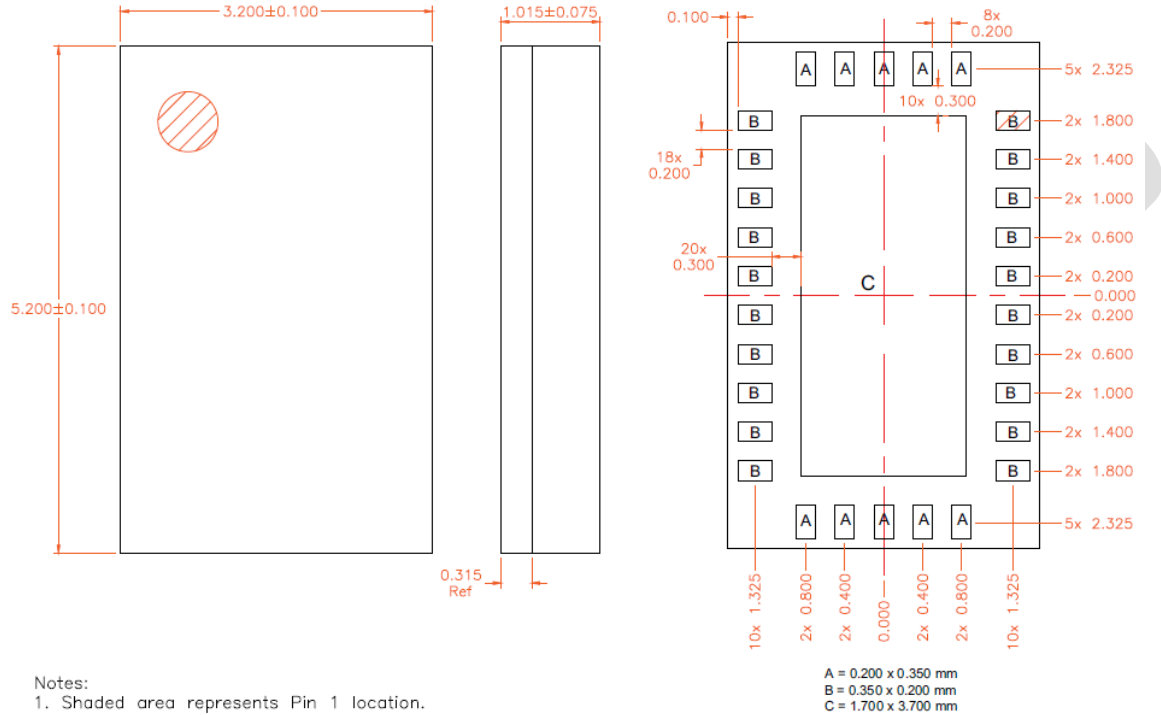

CONFIDENTIAL

PCB Pattern

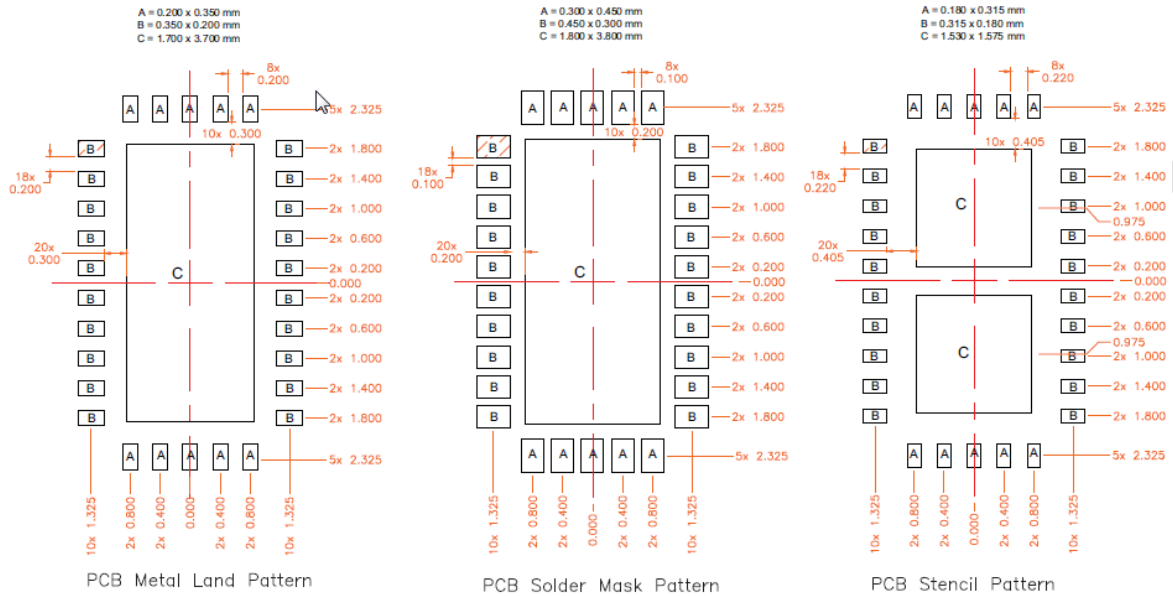

Notes:

1. Shaded area represents Pin 1 location.

CONFIDENTIAL

