

PRODUCT NO
SEE TABLE

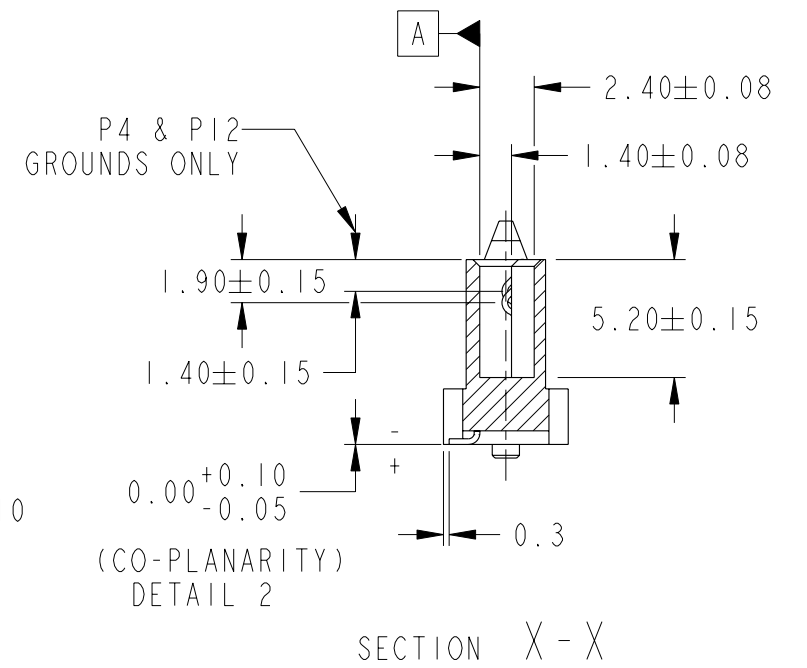
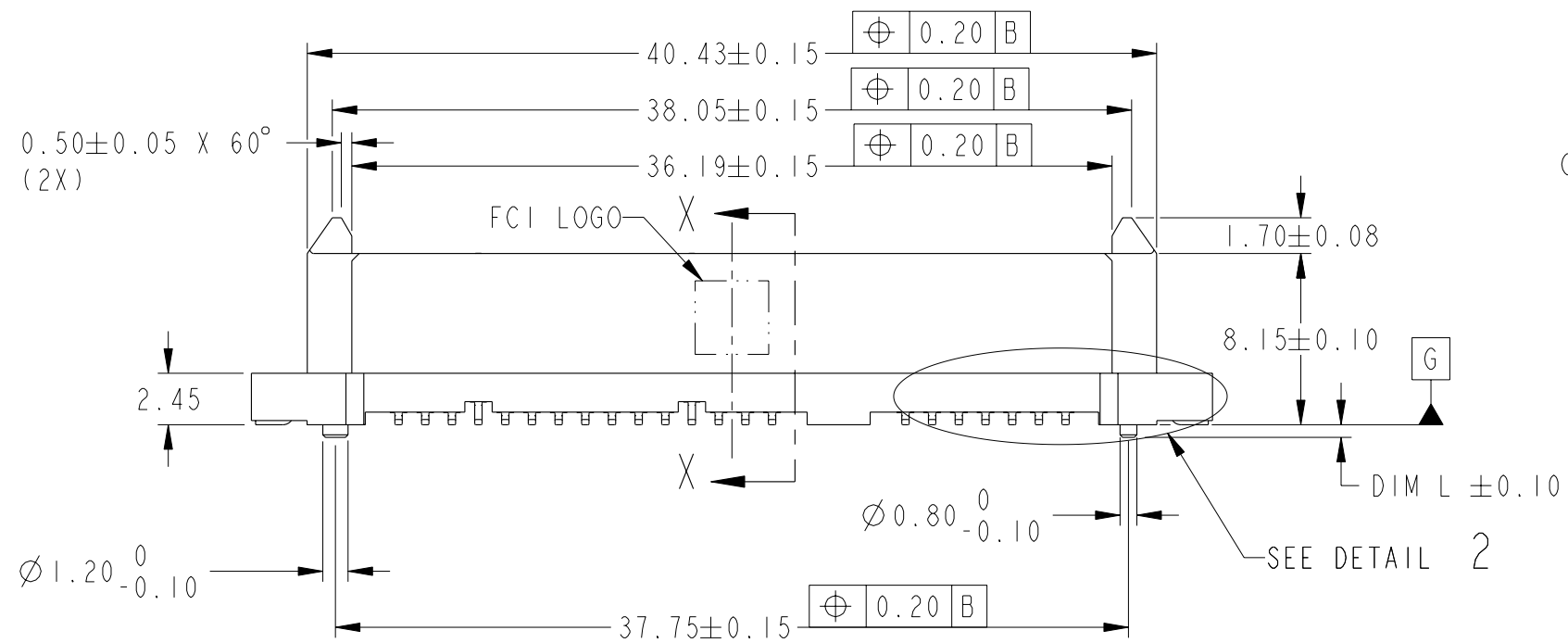
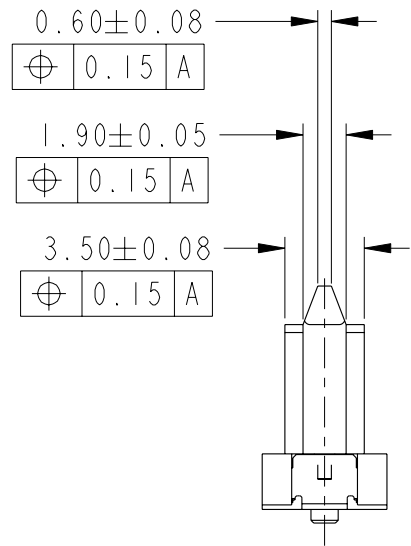
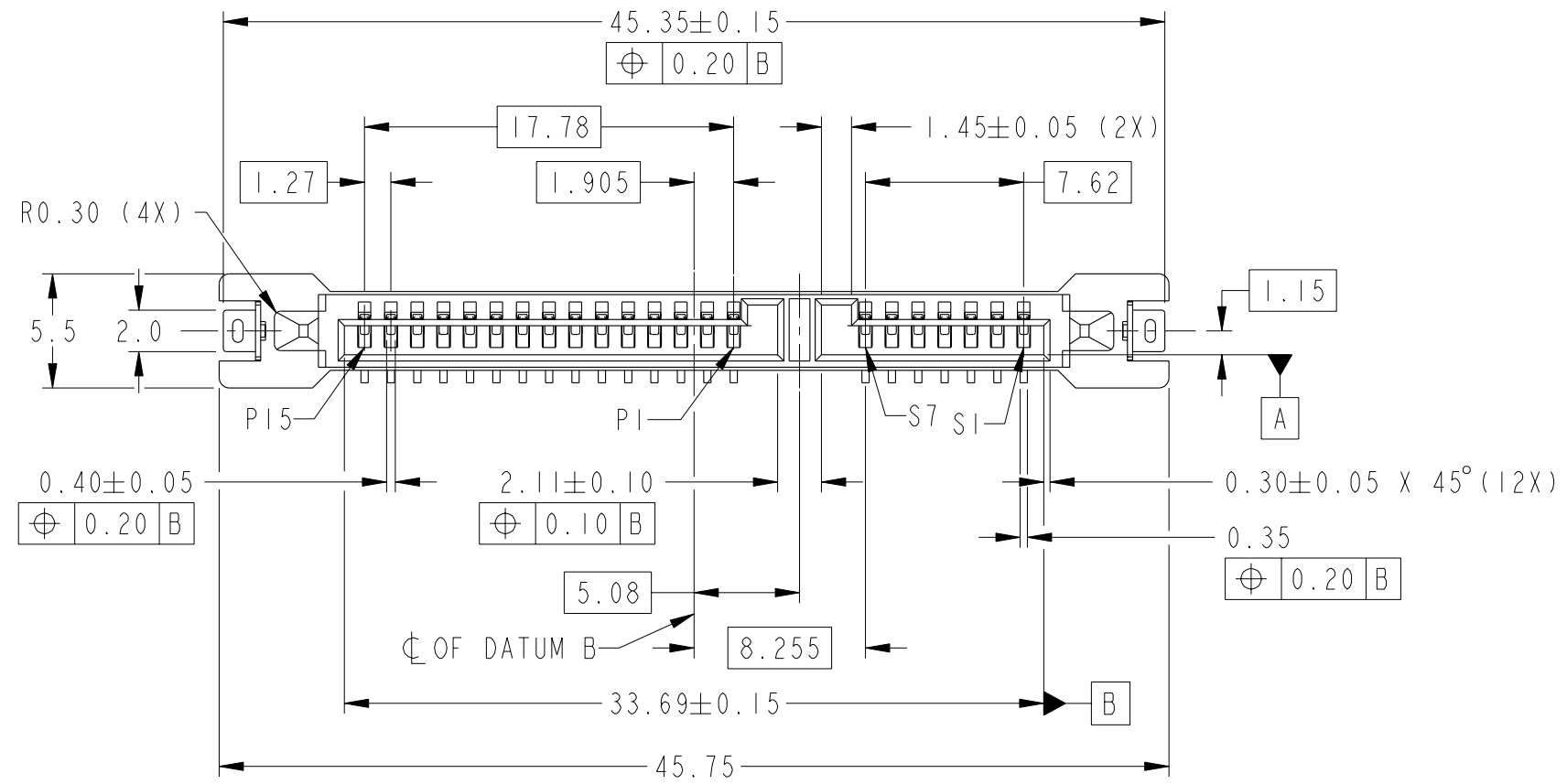

Copyright FCI.

spec ref	-	dr	GL LOO	2005-12-20	projection	MM	size	A3	scale	3:1
tolerance std	ISO 406 ISO 1101	eng	GL LOO	2005-12-20			ecn no	S10-0228	rel level	-
TOLERANCES UNLESS OTHERWISE SPECIFIED		chr	GL LOO	2010-10-28						
surface	ISO 1302	appr	JOEY NG	2010-10-28			rel level	-		
	linear	0.X	±							
		0.XX	±0.20							
		0.XXX	±							
	angular	0°	±2°							
				S-ATA COMB RECEP. VERTICAL SMT TYPE ASSY		dwg no 10042140		rev E		
		www.fci.com		cat. no. -		Product - Customer Drw		sheet 1 of 3		

PRODUCT NO	DIM L	PICK- UP CAP	PACKAGING
10042140-001LF	0.60	NO	STD TRAY
10042140-001CLF		YES	
10042140-001C-TRLF		YES	TAPE & REEL
10042140-003LF	1.45	NO	STD TRAY
10042140-003CLF		YES	
10042140-003C-TRLF		YES	TAPE & REEL

PRODUCT NO	DIM L	PICK-UP CUP	PACKAGING
10042140-002LF	0.60	NO	CUSTOM-MADE TRAY
10042140-002CLF		YES	

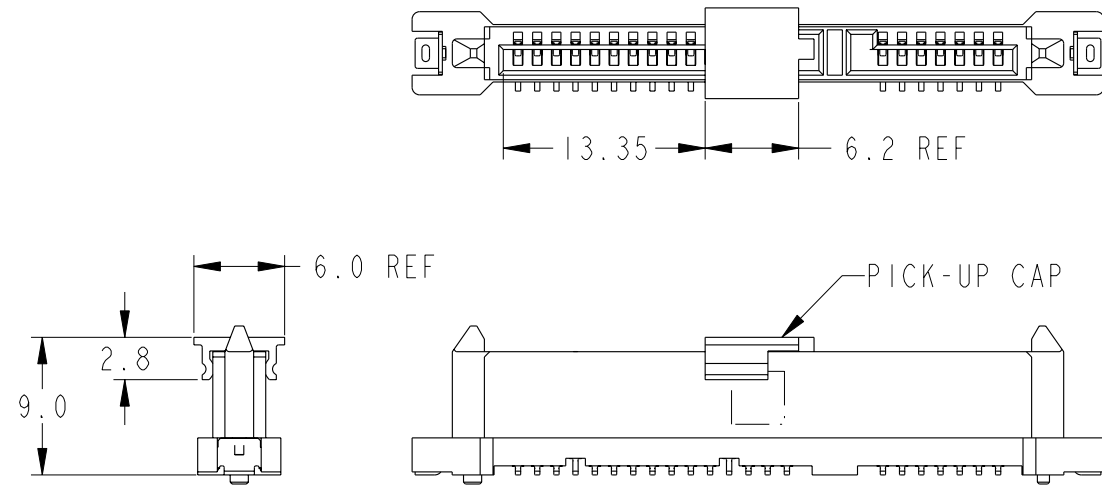

PART WITH PICK-UP CAP, SEE NOTE ④

SCALE 2:1

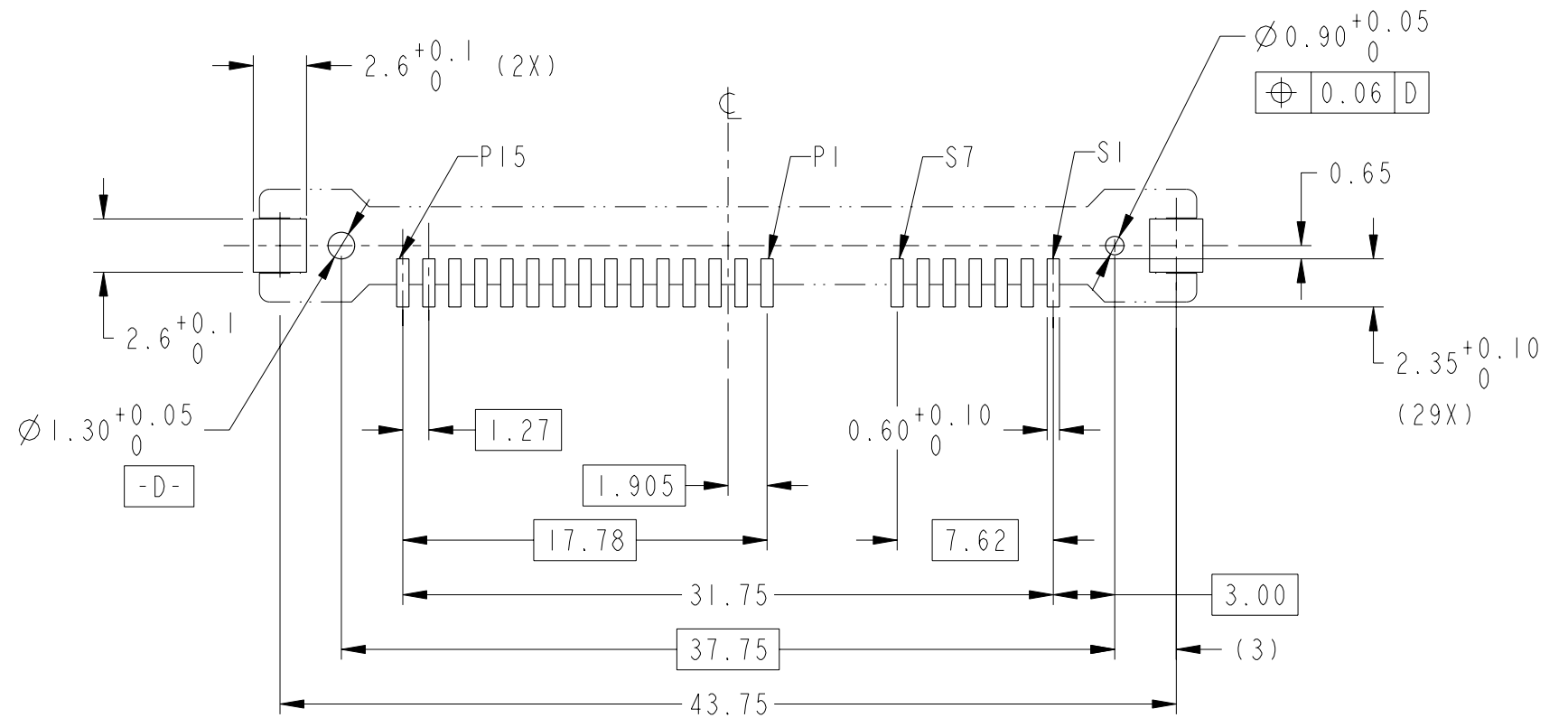

RECOMMENDED PCB LAYOUT

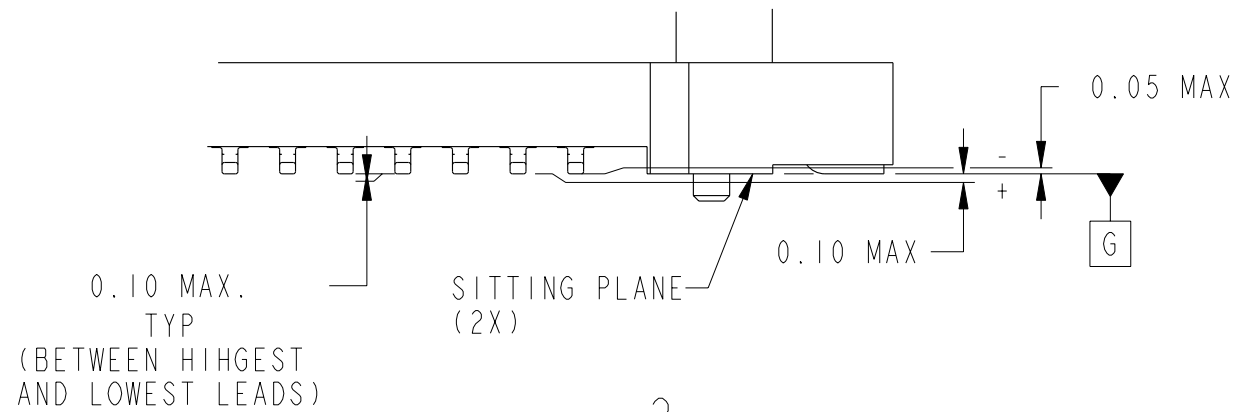

DETAIL 2
SCALE 6:1





spec ref	-	dr	GL LOO	2005-12-20	projection	MM	size	A3	scale	3:1
tolerance std	ISO 406 ISO 1101	eng	GL LOO	2005-12-20			ecn no	S10-0228	rel level	-
TOLERANCES UNLESS OTHERWISE SPECIFIED		chr	GL LOO	2010-10-28						
surface	ISO 1302	appr	JOEY NG	2010-10-28			rel level	-	dwg no	10042140
	linear	0.X	± -		S-ATA COMB RECEP. VERTICAL SMT TYPE ASSY		rev	E	-	
		0.XX	±0.20		cat. no.	-	Product - Customer Drw	sheet 2 of 3		
	angular	0°	±2°		www.fci.com		-		-	

NOTES:

- 1 THE UNMATING FORCE SHALL NOT BE LESS THAN 5N
- 2 MATERIAL :
 - 1) HOUSING : HIGH TEMP THERMOPLASTIC, UL 94V-0
 - COLOR : BLACK
 - 2) TERMINAL : COPPER ALLOY
 - 3) HOLD DOWN : COPPER ALLOY
- 3 FINISH :
 - 1) TERMINAL : 30μ" Au PLATING (CONTACT POINT) OVER 50μ" NICKEL
 - 2) SOLDER TAIL : 50μ" min Sn OVER 50μ" NICKEL
 - 3) HOLD DOWN : 50μ" min Sn OVER 50μ" NICKEL
- ④ PART WITH PICK-UP CAP, P/N XXXXXXXX-XXXC LF
- 5 THE STD PACKAGING IS IN TRAY.
- ⑥ FOR TAPE & REEL PACAGING SUFFIX "-TR" ADDED.
P/N XXXXXXXX-XXXC-TR LF
- 7 THE HOUSING WILL WITHSTAND EXPOSURE TO 260°C PEAK TEMPERATURE FOR 10 SECONDS IN A CONVECTION INFRA-RED OR VAPOR PHASE REFLOW OVEN.
- ⑧ THIS PRODUCT MEETS EUROPEAN UNION DIRECTIVES AND OTHER COUNTRY REGULATIONS AS DESCRIBES IN GS-22-008.
- 9 PART NUMBERS ENDING IN "LF" MEANS FOR NOTE 8 LEAD FREE IDENTIFICATION
- ⑩ A  SYMBOL WILL BE NEXT TO ANY DIMENSION, VIEW, OR NOTE WHICH HAS BEEN MODIFIED WITH THE CURRENT DRAWING REVISION

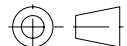

Copyright FCI.

spec ref	-	dr	GL LOO	2005-12-20	projection		size	A3	scale	3:1					
tolerance std	TOLERANCES UNLESS OTHERWISE SPECIFIED	eng	GL LOO	2005-12-20		MM	ecn no	S10-0228							
ISO 406		chr	GL LOO	2010-10-28			rel level	-							
ISO 1101		appr	JOEY NG	2010-10-28			product family	S-ATA							
surface 		linear	0.X	±-		S-ATA COMB RECEP. VERTICAL SMT TYPE ASSY	dwg no	10042140		rev	E				
ISO 1302		0.XX	±0.20	www.fci.com								cat. no.	-	Product - Customer Drw	sheet 3 of 3
	angular	0°	±2°												