

THIS DRAWING IS UNPUBLISHED. RELEASED FOR PUBLICATION JAN ,2006.

© COPYRIGHT 2006 BY TYCO ELECTRONICS CORPORATION. ALL RIGHTS RESERVED.

LOC	DIST	REVISIONS					
E	B	P	LTR	DESCRIPTION	DATE	DWN	APVD
		C		ECR-05-017969	17JAN06	JMS	FWK

NOTES:

- 1 PACK IN ACCORDANCE WITH AMP SPEC 107-3275
- 2 100 TRAY PACK IN ACCORDANCE WITH AMP SPEC 107-3275
- 3 Au PLATING
- 4 Ni PLATING
- 5 ELECTRICAL CHARACTERISTICS
 FREQUENCY RANGE: DC - 4 GHz
 NOMINAL IMPEDANCE: 50 Ohm
 INSULATION RESISTANCE: 5000 MOhm
 WORKING VOLTAGE: 500 Volts RMS at Sea Level
 DIELECTRIC WITHSTAND VOLTAGE: 1500 Volts RMS Max
 CONTACT RESISTANCE:
 CENTRE CONTACT: 1.50 mOhm Max
 OUTER CONTACT: 0.20 mOhm Max
- 6 MECHANICAL CHARATERISTICS
 DURABILITY: 500 Cycles Min
- 7 ENVIRONMENTAL CHARACTERISTICS
 OPERATING TEMPERATURE: -65 to +165 DegC

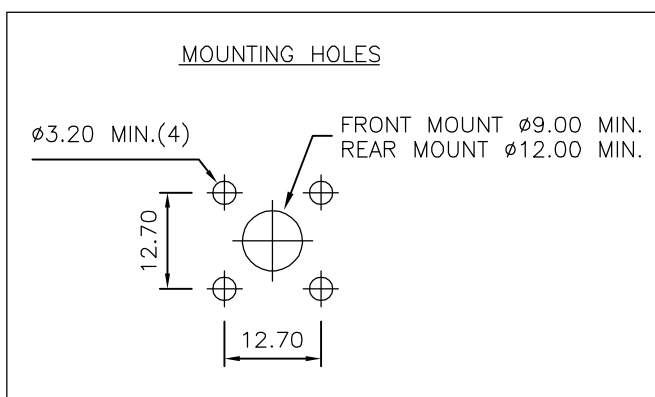
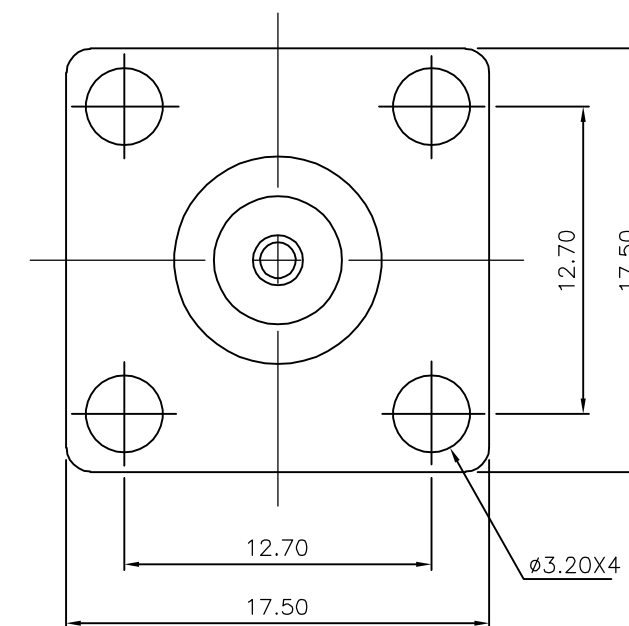
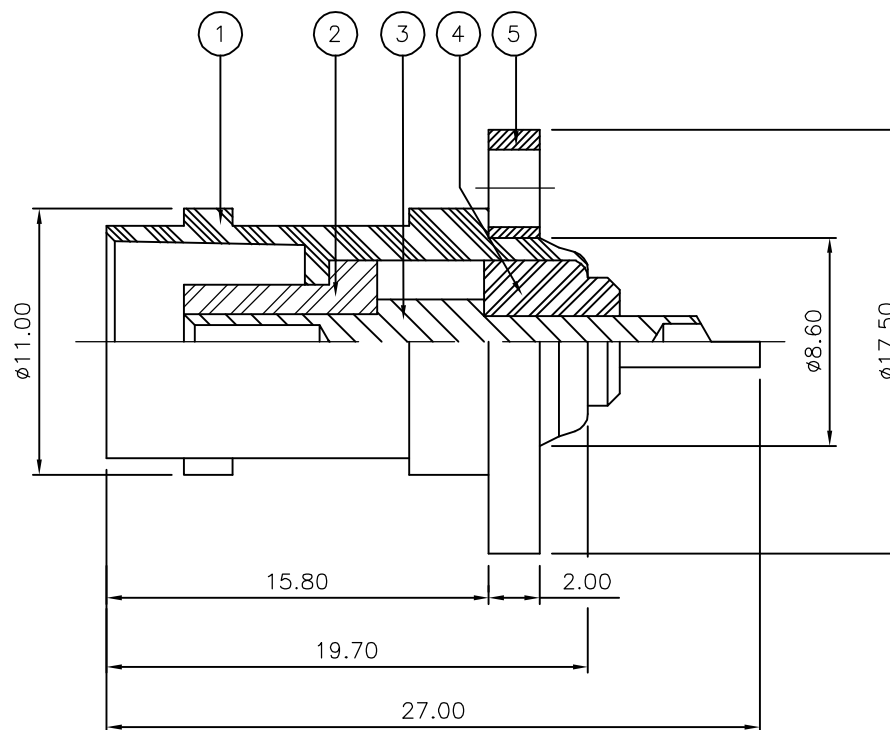

QTY	QTY	MATERIAL	DESCRIPTION	ITEM
1	1	BRASS	FLANGE	5
1	1	PTFE	INSULATION	4
1	1	BRASS	CONTACT	3
1	1	PTFE	INSULATION	2
1	1	BRASS	BODY	1
6--0	1--0	MATERIAL	DESCRIPTION	ITEM
QUANTITY PER ASSY		PARTS LIST		

THIS DRAWING IS A CONTROLLED DOCUMENT.		DWN	J.SANDWELL	17JAN06	 Tyco Electronics Corporation Bideford EX39 4HE	
DIMENSIONS: mm		CHK	S.PARLOW	17JAN06		
TOLERANCES UNLESS OTHERWISE SPECIFIED:		APVD	F.WHEELER-KING	17JAN06		
0 PLC ± - 1 PLC ± - 2 PLC ± - 3 PLC ± - 4 PLC ± - ANGLES ± - FINISH -		PRODUCT SPEC	NAME			BNC PANEL SOCKET 50 OHM
MATERIAL SEE TABLE		APPLICATION SPEC	WEIGHT -		SIZE	A3
		CUSTOMER DRAWING	SCALE NTS		CAGE CODE	00779
			DRAWING NO		RESTRICTED TO	-
			C-1337499		SHEET	1 OF 1
			REV		C	