

PRODUCT DATA DRAWING

REVISION HISTORY			
REV	DESCRIPTION	DATE	APPROVED
-	REL. DCN 36862	06/23/09	STW
A	DCN 40517	04/14	DAL
B	REV. DCN 42741	10/25/16	STW

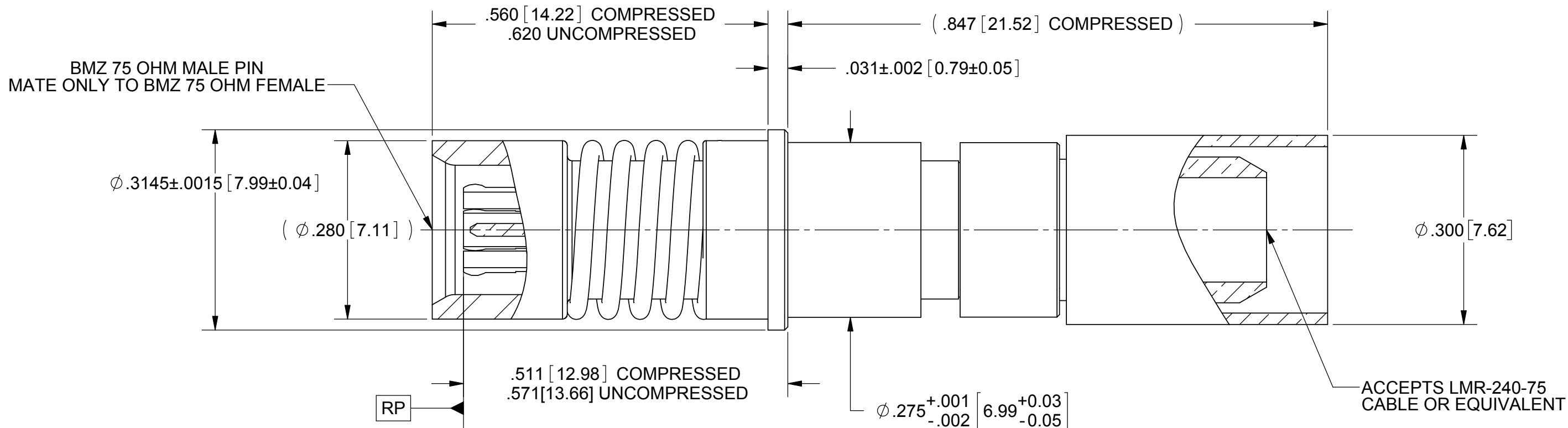

- MATERIAL:**
- BODY & SLEEVE:** STAINLESS STEEL PER AMS-5640, ALLOY UNS S30300, TYPE 1, OR ASTM A582, TYPE 303, CONDITION A.
- FERRULE & CRIMP RING:** BRASS PER ASTM B16 ALLOY UNS No. 36000
- CONTACT & LOCK RING:** BERYLLIUM COPPER PER ASTM B196, ALLOY No. UNS C17300, TD04.
- INSULATOR:** PTFE PER ASTM D1710, TYPE I, GRADE 1, CLASS B
- SPRING:** STAINLESS STEEL PER ASTM A313, TYPE 631.
- FINISH:**
- BODY, SLEEVE & SPRING:** PASSIVATED PER AMS-2700, TYPE 2.
- CONTACT:** GOLD PER ASTM B488, TYPE II, CODE C, CLASS 1.27, OVER NICKEL PER AMS-QQ-N-290, CLASS 1, .00005" MIN.
- FERRULE, CRIMP RING & LOCK RING:** NICKEL PER AMS-QQ-N-290.

- PERFORMANCE:**
- IMPEDANCE:** 75 OHMS
- FREQ. RANGE:** 950 TO 2150 MHz
- VSWR:** 1.5:1 950 TO 2150 MHz
- FINSERTION LOSS:** .06 X SQRT(F IN GHz)
- DWV:** 1000 VRMS
- OPERATING TEMP.:** -55°C TO +125°C

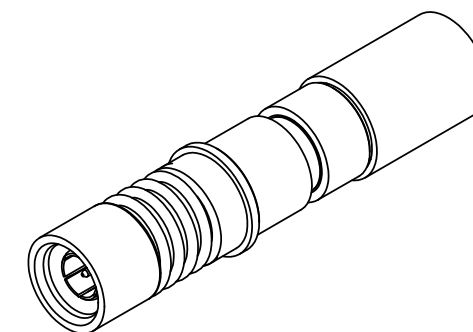

MATERIAL: SEE NOTES	DIMENSIONS ARE IN INCHES TOLERANCES: FRACTIONAL: $\pm 1/64$ ANGULAR: X° $\pm 1'0''$ X"X' $\pm 15''$	UNLESS OTHERWISE SPECIFIED 1) ALL DIMENSIONS ARE IN INCHES (MILLIMETERS) 2) ALL DIMENSIONS ARE AFTER PLATING. 3) BREAK CORNERS & EDGES .005 R. MAX. 4) CHAM. 1ST & LAST THREADS. 5) SURFACE ROUGHNESS $\sqrt{63}$ MIL-STD-10 6) DIA. 'S ON COMMON CENTERS TO BE CONCENTRIC WITHIN .005 T.I.R. 7) REMOVE ALL BURRS	SV Microwave, Inc. 2400 Centrepark West Drive, Suite 100 West Palm Beach, FL 33409
FINISH: SEE NOTES	DECIMAL: X $\pm .030$.XX $\pm .010$.XXX $\pm .005$	INTERPRET DIMENSIONS AND TOLERANCES PER ASME Y14.5M - 1994	TITLE: BMZ 75 OHM SOCKET FOR LMR-240-75 CABLE FIT M38999 SIZE 8 CAVITY
SURFACE AREA: N/A	PROPRIETARY THE INFORMATION CONTAINED IN THIS DRAWING IS THE SOLE PROPERTY OF SV MICROWAVE, INC. ANY REPRODUCTION IN PART OR AS A WHOLE WITHOUT THE WRITTEN PERMISSION OF SV MICROWAVE, INC IS PROHIBITED.	THIRD ANGLE PROJECTION	SIZE: B CAGE CODE: 95077 DWG. NO.: SF9811-60003
		DRAWN: JMC 10/20/08 CHECKED: STW 10/20/08 APPROVED: STW 10/20/08	SCALE: 6:1 SHEET 1 OF 1