

# Gate Driver Module DM Series

New  
Product

**Gate Driver Module integrates the functions required for the SiC MOSFET and IGBT gate drivers.**

This product is a next-generation drive module that emphasizes common mode noise preventive measures in particular.



## Features

- Low common mode noise (parasitic capacitance: 15pF TYP)
- Fast response (100ns TYP)
- All-in-one (built-in DC-DC converter/Gate driver)
- It corresponds to a module of 2in1 type. 2 drive circuits are separate respectively.
- Dielectric withstand voltage: AC2500Vrms
- Electrolytic capacitor

## Circuit diagram

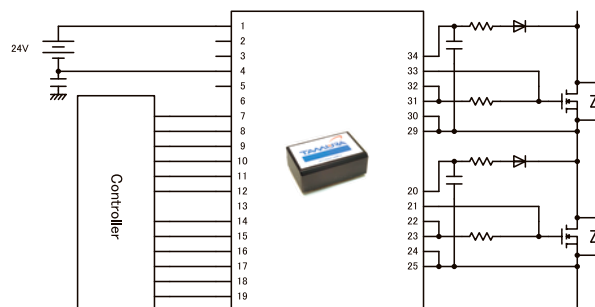

## Outline Drawing Unit : mm

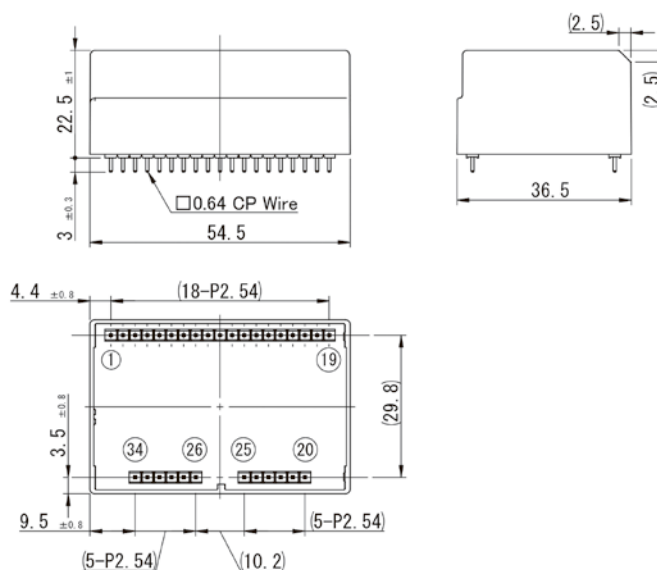

Model		SiC Driver	IGBT Driver		
		2DM180506CM	2DM150806CM	2DM150606CM	
Input	Supply voltage range	DC13V to DC28V/DC24V			
	Input signal voltage	5V			
Output	Number of drive circuits	2			
	Maximum output power	3W (per circuit)			
	Output terminal voltage (H)	+17V to +19V	+14V to +16V	+14V to +16V	
	Output terminal voltage (L)	-4V to -6V	-7V to -9V	-5V to -7V	
	Switching frequency	200kHz max			
	Gate drive capability		2600nC/50kHz 650nC/200kHz	2700nC/50kHz 700nC/200kHz	
		(When the output power per circuit is equivalent to 3W)			
Maximum output current	18A peak (guaranteed by design)				
Delay time	100nsec. (typ.)				
Mirror clamp detection	Operation with Output terminal voltage +2Vtyp.; -3A peak (guaranteed by design)				
Desaturation protection function	Fault signal output function; Recovery by turning on the reset input again.				
Signal transmission method (isolation circuit)	Magnetic				
Dielectric withstand voltage	AC2500V/ 1min. Note: Between input and output; Between drive circuits				
Operating temperature range	-30°C to +85°C; Maximum output power at 85°C: Approximately 1W (per circuit) Note: Temperature derating may occur depending on the drive conditions.				
Operating humidity range	20% to 95% RH (No condensing)				



## TAMURA CORPORATION

Contact Tamura Corporation for further information. E-mail: soudan@tamura-ss.co.jp

Sakado Factory : 5-5-30, Chiyoda, Sakado-shi, Saitama 350-0214, Japan

Osaka Sales Office : No.2 Esaka-Sansho Bldg., 3-27-27, Tarumicho, Suita-shi, Osaka 564-0062, Japan

Nagoya Sales Office : 3-1803, Kamiyashiro, Meito-ku, Nagoya-shi, Aichi 465-0025, Japan

TEL. +81-49-284-2323 FAX. +81-49-284-9183

TEL. +81-6-6380-2300 FAX. +81-6-6385-8371

TEL. +81-52-701-1210 FAX. +81-52-701-1295