

THIS DRAWING IS UNPUBLISHED. RELEASED FOR PUBLICATION 20
 © COPYRIGHT 20 BY TYCO ELECTRONICS CORPORATION. ALL RIGHTS RESERVED.

LOC		DIST		REVISIONS			
P	LTR	DESCRIPTION	DATE	DWN	APVD		
-	-	-	-	-	-		
A		REVISED PER ECR-09-020309	23SEP2009	HMR	DD		

- △ MATERIAL: PBT. COLOR: YELLOW
- 2. THIS PRODUCT HAS NOT COMPLETED VALIDATION TESTING
- 3. MUST COMPLY WITH DIRECTIVE 2002/95/EC (ROHS)
- △ THIS DIMENSION DENOTES SURFACE THAT ALIGNS WITH EDGE OF PCB

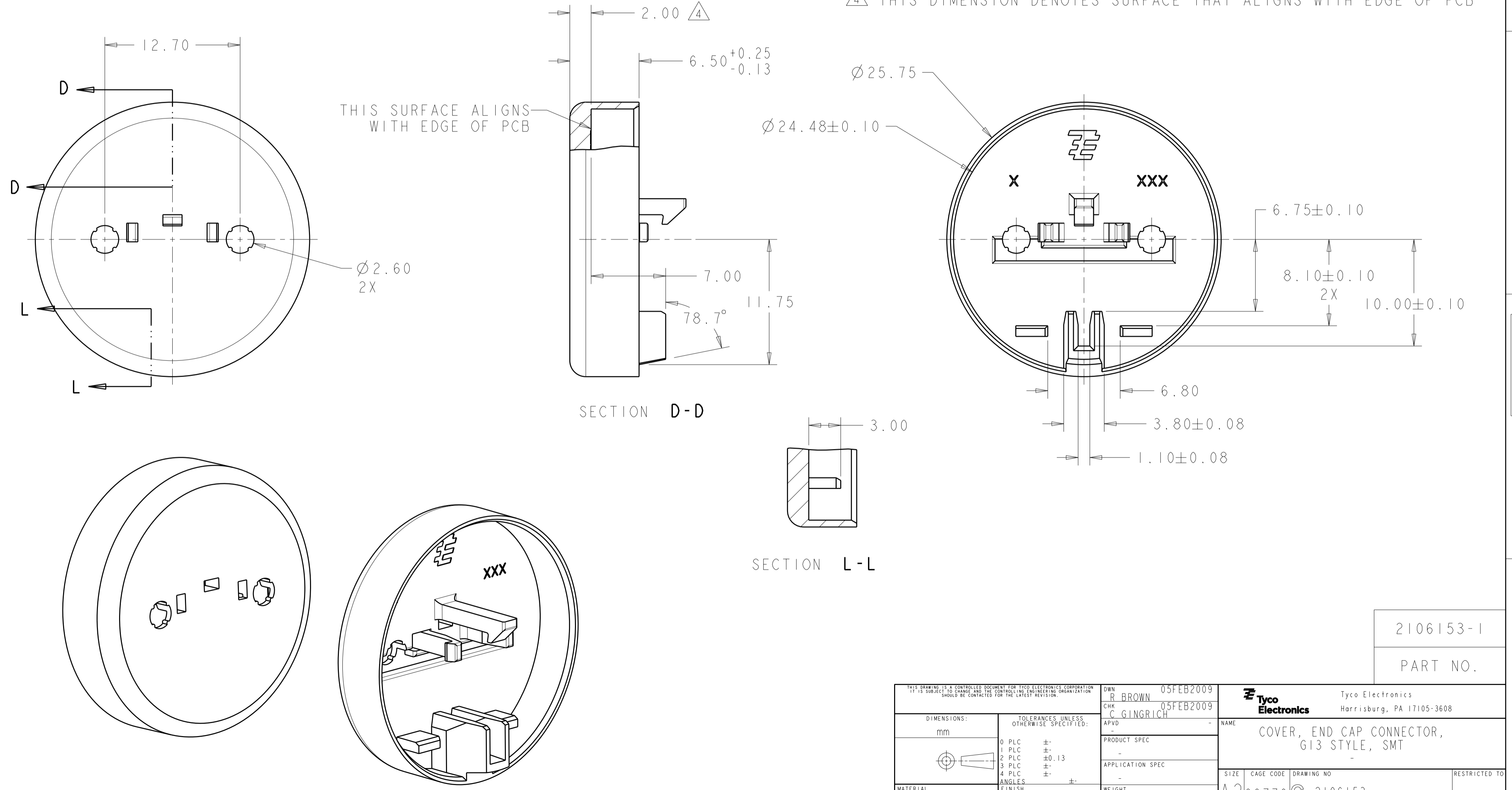

2106153-1
 PART NO.

THIS DRAWING IS A CONTROLLED DOCUMENT FOR TYCO ELECTRONICS CORPORATION. IT IS SUBJECT TO CHANGE AND THE CONTROLLING ENGINEERING ORGANIZATION SHOULD BE CONTACTED FOR THE LATEST REVISION.		DWN R. BROWN 05FEB2009	Tyco Electronics Harrisburg, PA 17105-3608	
DIMENSIONS: mm		CHK C. GINGRICH 05FEB2009	NAME COVER, END CAP CONNECTOR, G13 STYLE, SMT	
TOLERANCES UNLESS OTHERWISE SPECIFIED: 0 PLC ±- 1 PLC ±- 2 PLC ±0.13 3 PLC ±- 4 PLC ±- ANGLES ±- FINISH		APVD -	PRODUCT SPEC -	APPLICATION SPEC -
MATERIAL △ -		WEIGHT -	SIZE A200779	CAGE CODE C-2106153
CUSTOMER DRAWING		SCALE 4:1	SHEET 1	REV A