

THIS DRAWING IS UNPUBLISHED. RELEASED FOR PUBLICATION
 © COPYRIGHT copyright.d8te- ALL RIGHTS RESERVED.

REVISIONS				
P	LTR	DESCRIPTION	DATE	APVD
	A	RELEASED FOR PRODUCTION	23OCT2017	RK PO

NOTES:

- 1 LID NOT ASSEMBLED WITH LOWER PART. ENCLOSED LOOSELY
- 2 FLAP NOT ASSEMBLED WITH LOWER PART. ENCLOSED LOOSELY
- 3 PART NUMBER.
- 4 PRODUCTION DATE (YYMMDD)
- 5 MANUFACTURING LOCATION CODE.
- 6 OMEGA CLIP AS LOOSE PIECE IN BOX, PRODUCT SPEC. 108-94176
- 7 MODEL CODE ACCORDING TE-SPEC. 404-74000-1
- 8 CONSECUTIVE SERIAL NUMBER
- 9 TEST EQUIPMENT NUMBER
- 10 DIODES WELDED ON CONTACT RAIL
- 11. MUST COMPLY WITH DIRECTIVE 2002/95/EC (ROHS).
- 12. THIS PRODUCT HAS NOT COMPLETED VALIDATION TESTING.

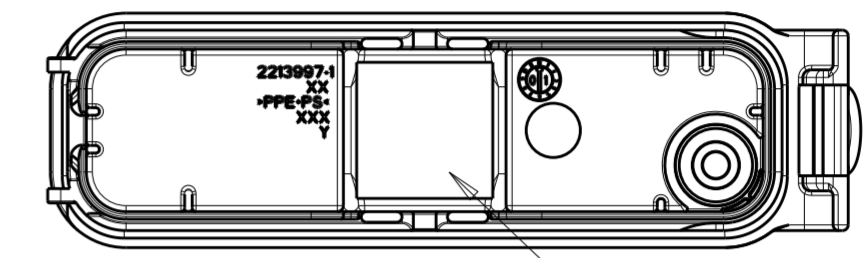
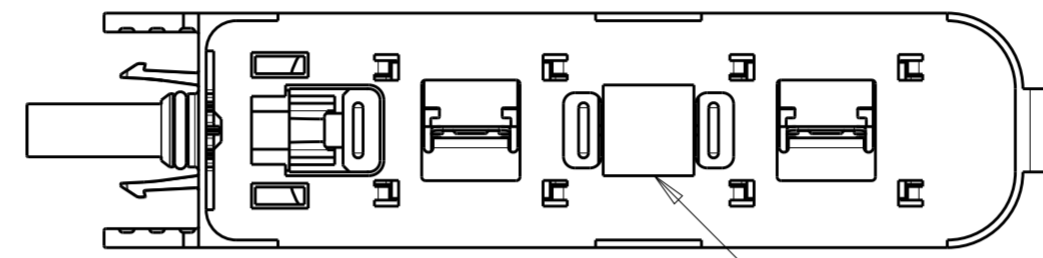

BOTTOM VIEW OF TYPICAL ASSEMBLY WHEN MOUNTING TAPE IS APPLIED

BOTTOM VIEW OF LID SUBASSEMBLY WHEN THERMAL INTERFACE MATERIAL IS APPLIED

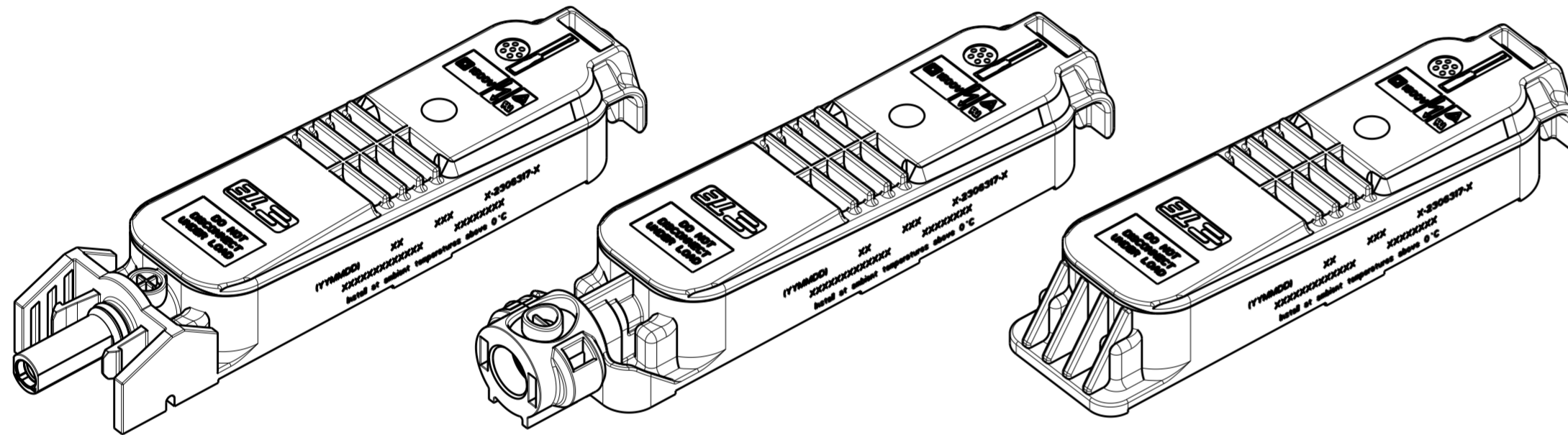

PVEDGE2GGA1V_2	36.0	EAST/WEST	YES	YES	7-2306317-5	
PVEDGE2DGA1V_2	55.2	EAST/WEST	YES	YES	7-2306317-2	
PVEDGE2FGA1V_2	58.7	EAST/WEST	YES	YES	7-2306317-1	
PVEDGE2GGA1V_2	36.0	EAST/WEST	NO	YES	6-2306317-5	
PVEDGE2DGA1V_2	55.2	EAST/WEST	NO	YES	6-2306317-2	
PVEDGE2FGA1V_2	58.7	EAST/WEST	NO	YES	6-2306317-1	
PVEDGE2GGA1T_2	36.0	EAST/WEST	YES	NO	5-2306317-5	
PVEDGE2DGA1T_2	55.2	EAST/WEST	YES	NO	5-2306317-2	
PVEDGE2FGA1T_2	58.7	EAST/WEST	YES	NO	5-2306317-1	
PVEDGE2GGA1T_2	36.0	EAST/WEST	NO	NO	4-2306317-5	
PVEDGE2DGA1T_2	55.2	EAST/WEST	NO	NO	4-2306317-2	
PVEDGE2FGA1T_2	58.7	EAST/WEST	NO	NO	4-2306317-1	
PVEDGE2GGA1V_2	36.0	NORTH/SOUTH	YES	YES	3-2306317-5	
PVEDGE2DGA1V_2	55.2	NORTH/SOUTH	YES	YES	3-2306317-2	
PVEDGE2FGA1V_2	58.7	NORTH/SOUTH	YES	YES	3-2306317-1	
PVEDGE2GGA1V_2	36.0	NORTH/SOUTH	NO	YES	2-2306317-5	
PVEDGE2DGA1V_2	55.2	NORTH/SOUTH	NO	YES	2-2306317-2	
PVEDGE2FGA1V_2	58.7	NORTH/SOUTH	NO	YES	2-2306317-1	
PVEDGE2GGA1T_2	36.0	NORTH/SOUTH	YES	NO	1-2306317-5	
PVEDGE2DGA1T_2	55.2	NORTH/SOUTH	YES	NO	1-2306317-2	
PVEDGE2FGA1T_2	58.7	NORTH/SOUTH	YES	NO	1-2306317-1	
PVEDGE2GGA1T_2	36.0	NORTH/SOUTH	NO	NO	2306317-5	
PVEDGE2DGA1T_2	55.2	NORTH/SOUTH	NO	NO	2306317-2	
PVEDGE2FGA1T_2	58.7	NORTH/SOUTH	NO	NO	2306317-1	
Model Code	7	DIM X	PV PANEL FOIL DIRECTION	MONUTING TAPE	THERMAL INTERFACE MATERIAL	PART NO.

TIN OVER NICKEL	COPPER ALLOY	INTERFACE CONTACT-SOCKET	11
TIN OVER NICKEL	COPPER ALLOY	INTERFACE CONTACT-PIN	10
-	-	THERMAL INTERFACE MATERIAL	9
-	-	BYPASS DIODE: TYPE SL2020A	8
GRAY	PPE+PS	MEMBRANE RETAINER	7
-	-	MEMBRANE VENT	6
PLAIN	STAINLESS STEEL	OMEGA CLIP	5 6
TIN	COPPER ALLOY	CONTACT RAIL	4
BLACK	PPE+PS	BOX, LOWER HOUSING	3
RED	SILICONE	O-RING SEAL	2
BLACK	PPE+PS	BOX, LID	1 1
COLOR/FINISH	MATERIAL	DESCRIPTION	ITEM NO.

THIS DRAWING IS A CONTROLLED DOCUMENT.

DIMENSIONS: mm

TOLERANCES UNLESS OTHERWISE SPECIFIED:

0 PLC	±0.50
1 PLC	±0.25
2 PLC	±0.13
3 PLC	±
4 PLC	±
ANGLES	±
FINISH	-

MATERIAL 1

APVD: 13AUG2016, RAVI S, GINGRICH CHUCK

PRODUCT SPEC: 108-32122

APPLICATION SPEC: 114-32157

SCALE: 1:1

SHEET 1 OF 4

REV A

STE TE Connectivity

NAME: PV EDGE ASSEMBLY, WITHOUT FLAP, OMEGA CLIP

SIZE: A2

DRAWING NO: C-2306317

RESTRICTED TO: -

THIS DRAWING IS UNPUBLISHED. RELEASED FOR PUBLICATION
 © COPYRIGHT copyright.d8te- ALL RIGHTS RESERVED.

REVISIONS				
P	LTR	DESCRIPTION	DATE	APVD
-		SEE SHEET 1	-	-

LID NOT SHOWN FOR REFERENCE ONLY

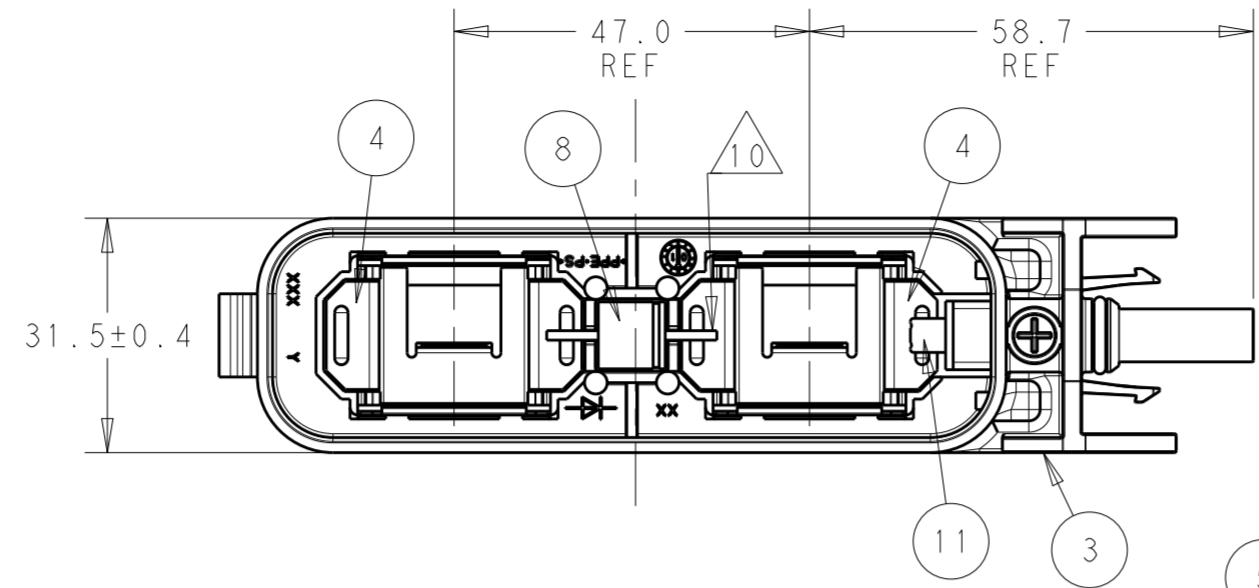

LID NOT SHOWN FOR REFERENCE ONLY

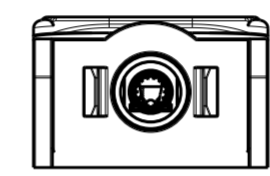
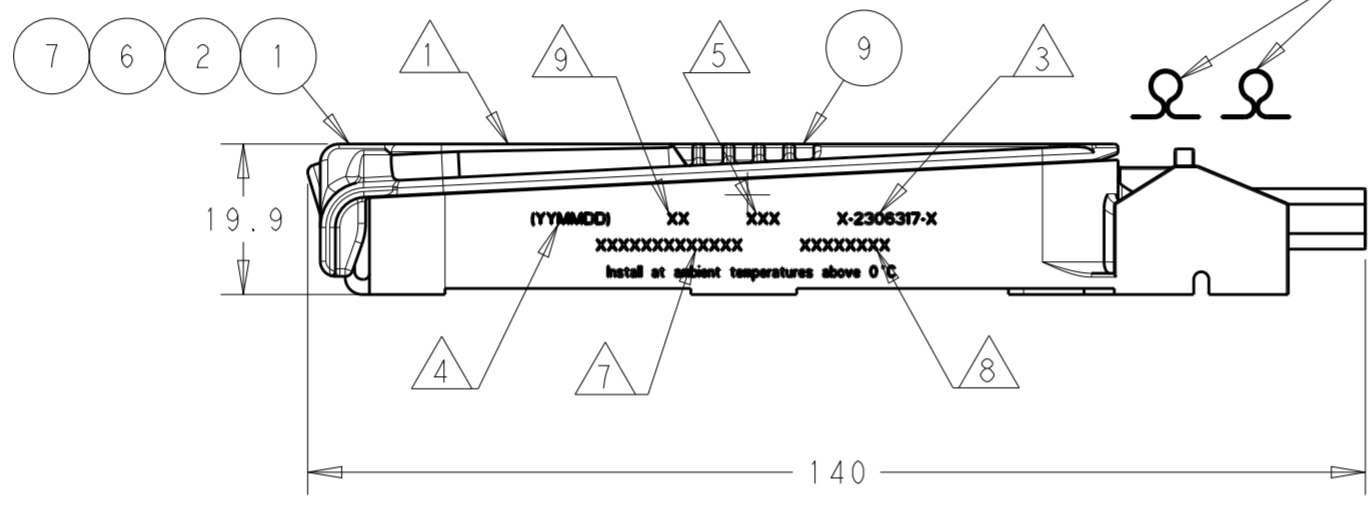
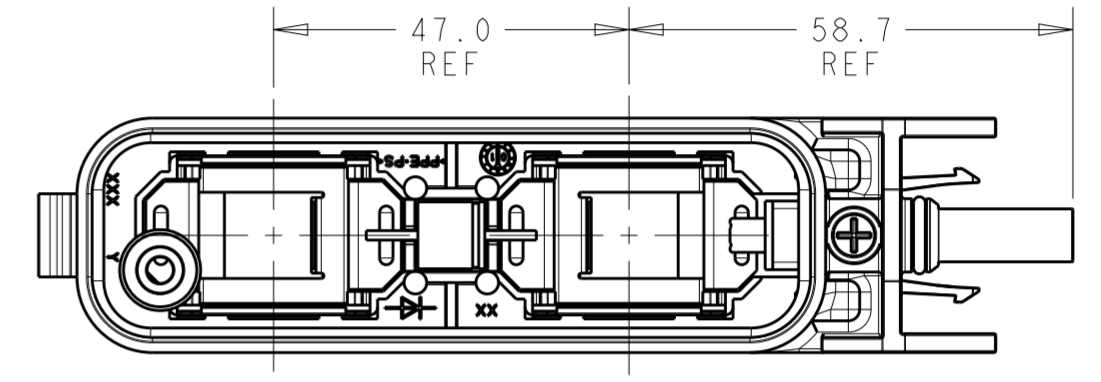

NORTH-SOUTH VERSIONS
 2306317-1
 1-2306317-1
 2-2306317-1
 3-2306317-1
 SHOWN

EAST-WEST VERSIONS
 4-2306317-1
 5-2306317-1
 6-2306317-1
 7-2306317-1
 SAME AS N-S VERSIONS
 EXCEPT AS SHOWN

LID NOT SHOWN FOR REFERENCE ONLY

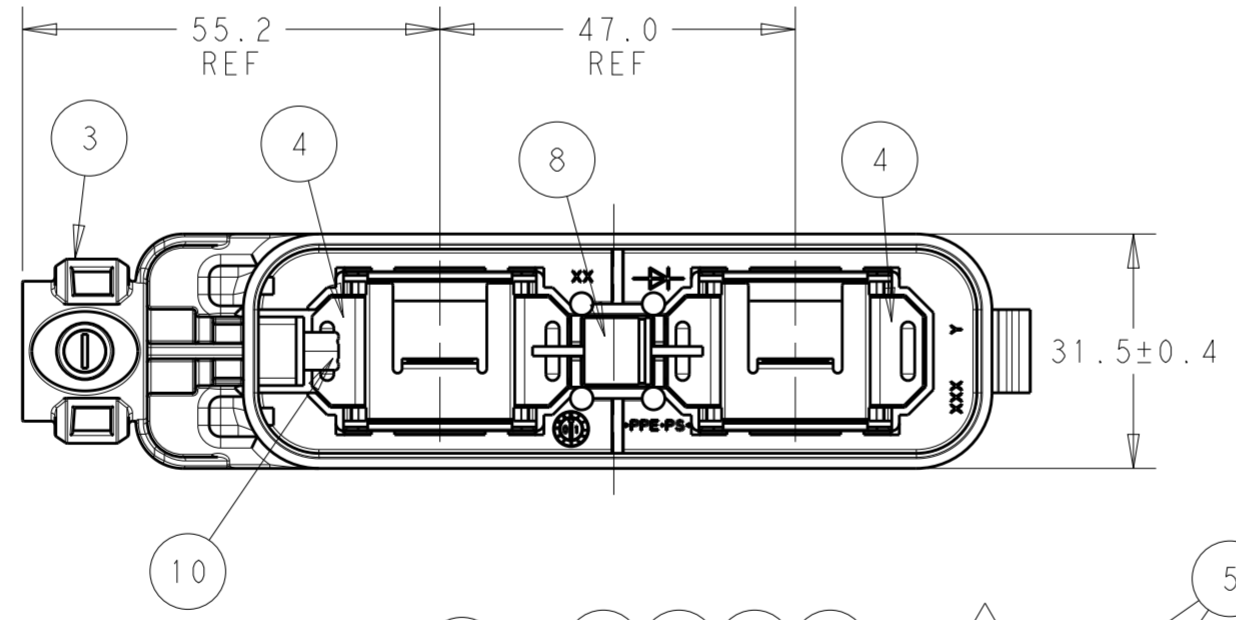

LID NOT SHOWN FOR REFERENCE ONLY

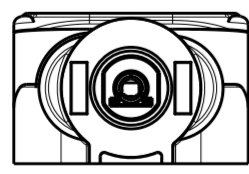
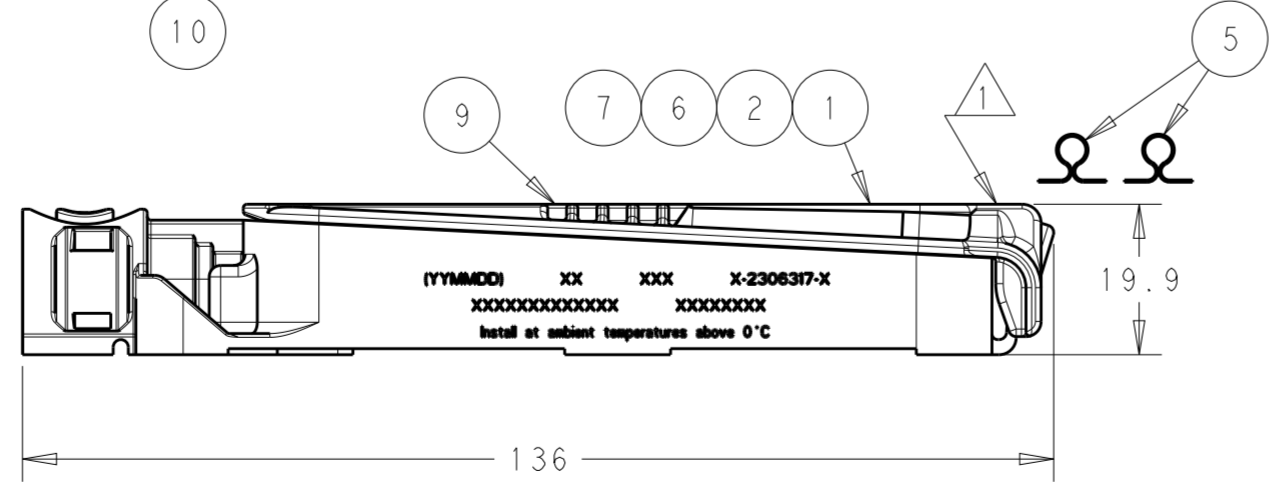
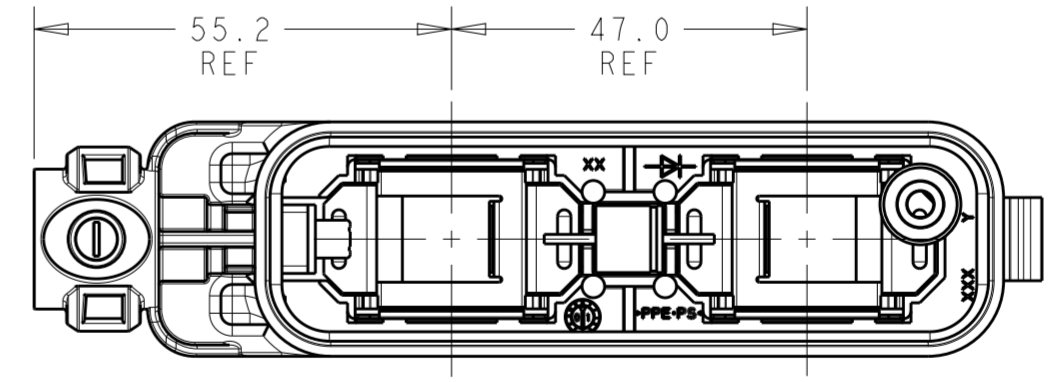

NORTH-SOUTH VERSIONS
 2306317-2
 1-2306317-2
 2-2306317-2
 3-2306317-2
 SHOWN

EAST-WEST VERSIONS
 4-2306317-2
 5-2306317-2
 6-2306317-2
 7-2306317-2
 SAME AS N-S VERSIONS
 EXCEPT AS SHOWN

THIS DRAWING IS A CONTROLLED DOCUMENT.		DWN RAVLS 13AUG2016	TE Connectivity	
DIMENSIONS: mm		CHK GINGRICH CHUCK 13AUG2016		
TOLERANCES UNLESS OTHERWISE SPECIFIED:		APVD GINGRICH CHUCK 13AUG2016	NAME PV EDGE ASSEMBLY, WITHOUT FLAP, OMEGA CLIP	
0 PLC ±0.50		PRODUCT SPEC 108-32122	RESTRICTED TO	
1 PLC ±0.25		APPLICATION SPEC 114-32157	SIZE A2	CAGE CODE G-2306317
2 PLC ±0.13		WEIGHT -	SCALE 5:1	SHEET 2 OF 4
3 PLC ±		CUSTOMER DRAWING	REV A	
4 PLC ±				
ANGLES ±				
FINISH -				

THIS DRAWING IS UNPUBLISHED. RELEASED FOR PUBLICATION
 © COPYRIGHT copyright.d8te- ALL RIGHTS RESERVED.

REVISIONS				
P	LTR	DESCRIPTION	DATE	APVD
-		SEE SHEET 1	-	-

LID NOT SHOWN FOR REFERENCE ONLY

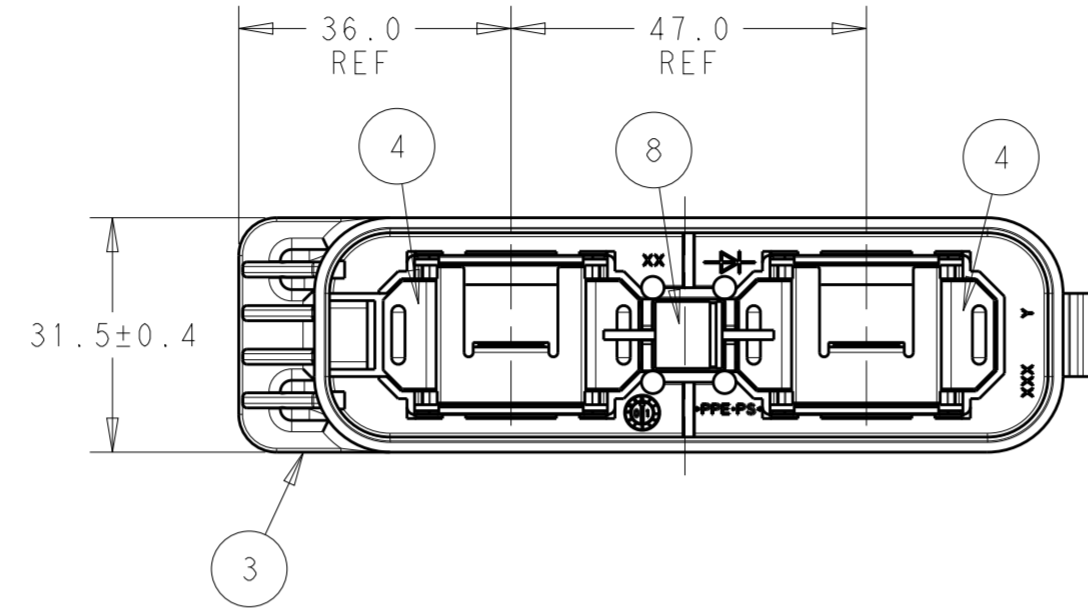

LID NOT SHOWN FOR REFERENCE ONLY

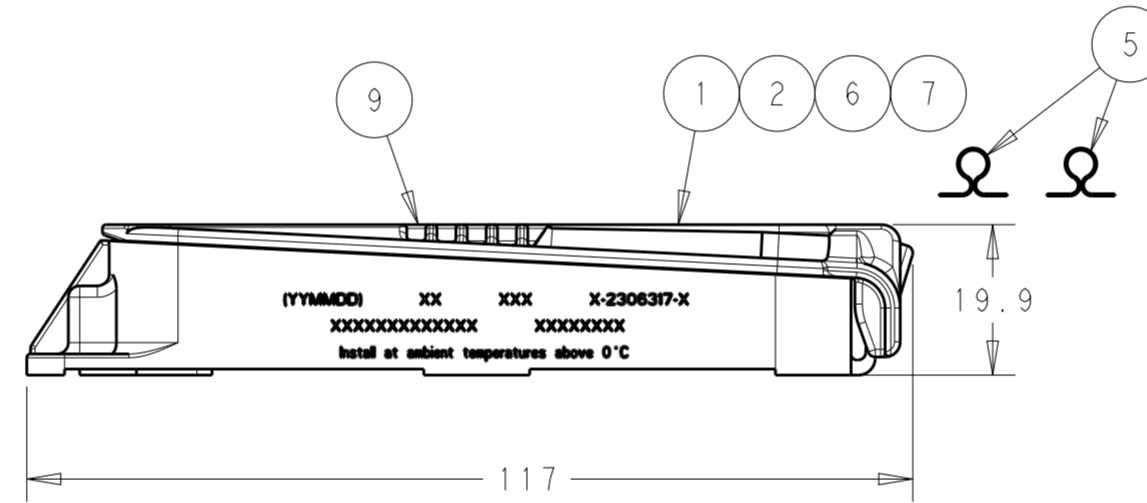
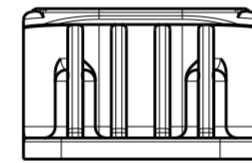
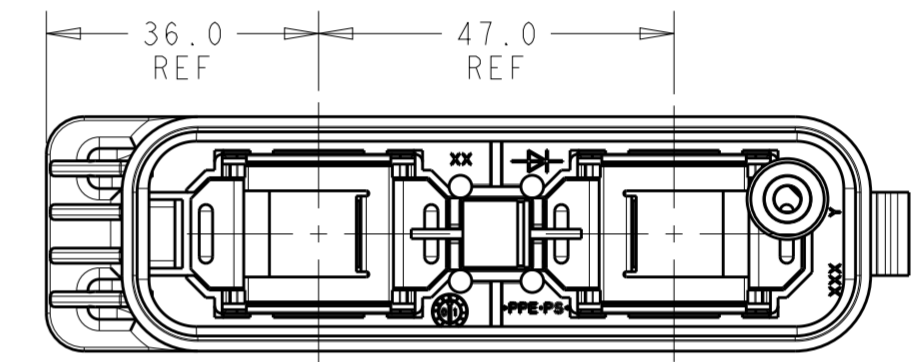

EAST-WEST VERSIONS
 4-2306317-5
 5-2306317-5
 6-2306317-5
 7-2306317-5
 SAME AS N-S VERSIONS
 EXCEPT AS SHOWN

NORTH-SOUTH VERSIONS
 2306317-5
 1-2306317-5
 2-2306317-5
 3-2306317-5
 SHOWN

THIS DRAWING IS A CONTROLLED DOCUMENT.		DWN RAVLS 13AUG2016	TE Connectivity															
DIMENSIONS: mm		CHK GINGRICH CHUCK 13AUG2016																
TOLERANCES UNLESS OTHERWISE SPECIFIED:		APVD GINGRICH CHUCK 13AUG2016	NAME PV EDGE ASSEMBLY, WITHOUT FLAP, OMEGA CLIP															
<table border="0"> <tr><td>0 PLC</td><td>±0.50</td></tr> <tr><td>1 PLC</td><td>±0.25</td></tr> <tr><td>2 PLC</td><td>±0.13</td></tr> <tr><td>3 PLC</td><td>±</td></tr> <tr><td>4 PLC</td><td>±</td></tr> <tr><td>ANGLES</td><td>±</td></tr> <tr><td>FINISH</td><td>-</td></tr> </table>		0 PLC	±0.50	1 PLC	±0.25	2 PLC	±0.13	3 PLC	±	4 PLC	±	ANGLES	±	FINISH	-	PRODUCT SPEC 108-32122	SIZE A2	
0 PLC	±0.50																	
1 PLC	±0.25																	
2 PLC	±0.13																	
3 PLC	±																	
4 PLC	±																	
ANGLES	±																	
FINISH	-																	
MATERIAL		APPLICATION SPEC 114-32157	DRAWING NO C-2306317															
		WEIGHT -	RESTRICTED TO -															
		CUSTOMER DRAWING	SCALE 5:1 SHEET 3 OF 4 REV A															

THIS DRAWING IS UNPUBLISHED. RELEASED FOR PUBLICATION
 © COPYRIGHT copyright.d8te- ALL RIGHTS RESERVED.

REVISIONS				
P	LTR	DESCRIPTION	DATE	APVD
-	-	SEE SHEET 1	-	-

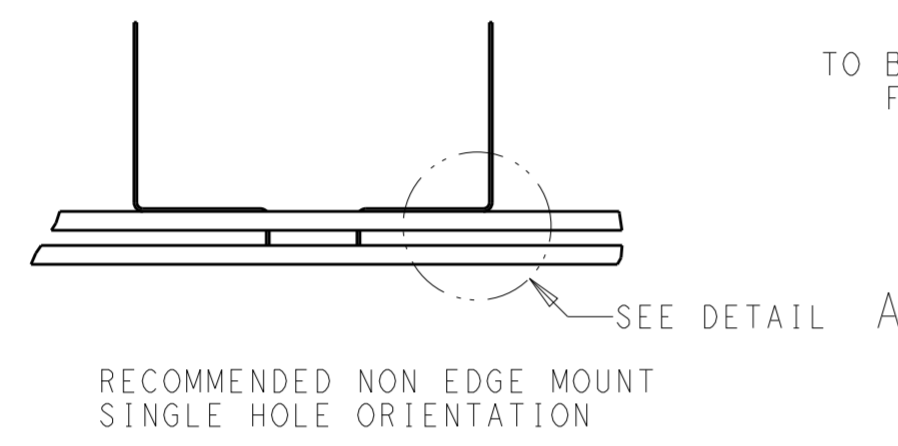
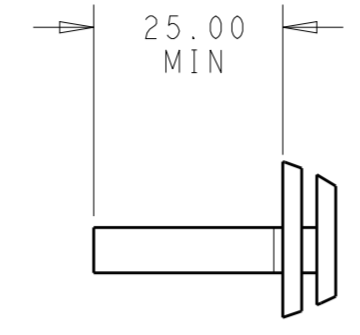
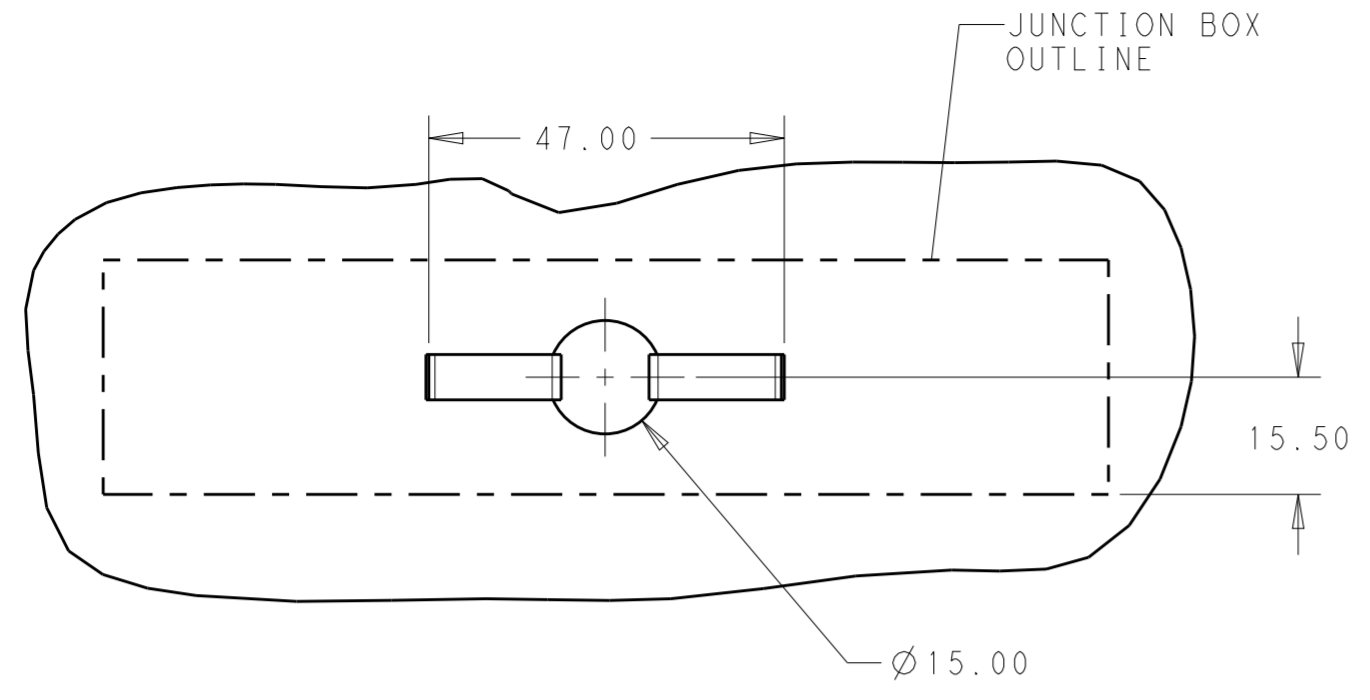

0.8 MAX TO BOTTOM SIDE OF FOIL FROM BOTTOM SIDE OF GLASS
 SEE 114-32157 FOR FOIL THICKNESS RANGE

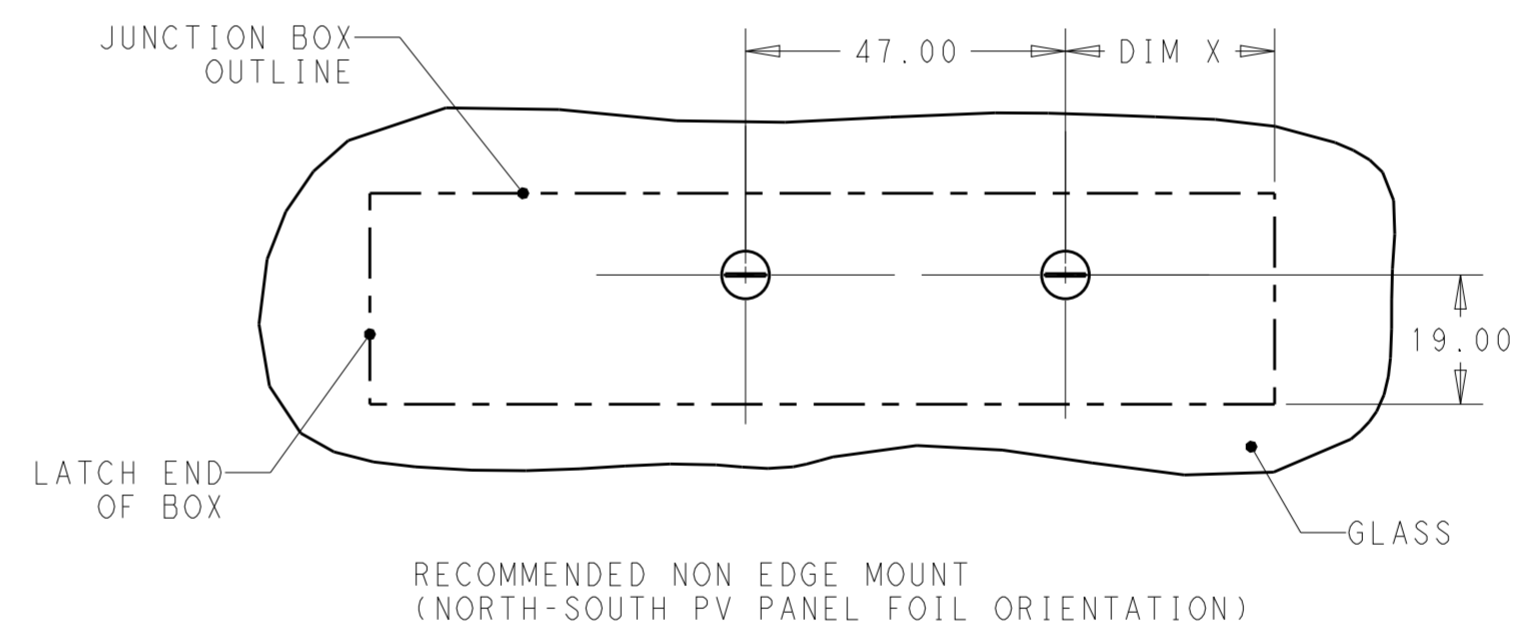
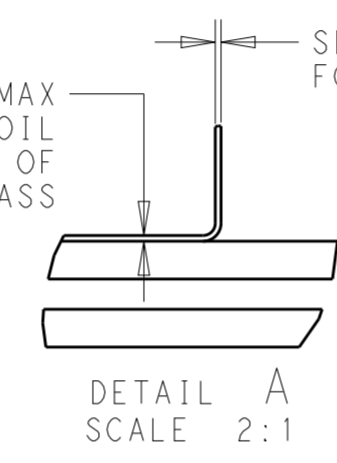

RECOMMENDED NON EDGE MOUNT (NORTH-SOUTH PV PANEL FOIL ORIENTATION)

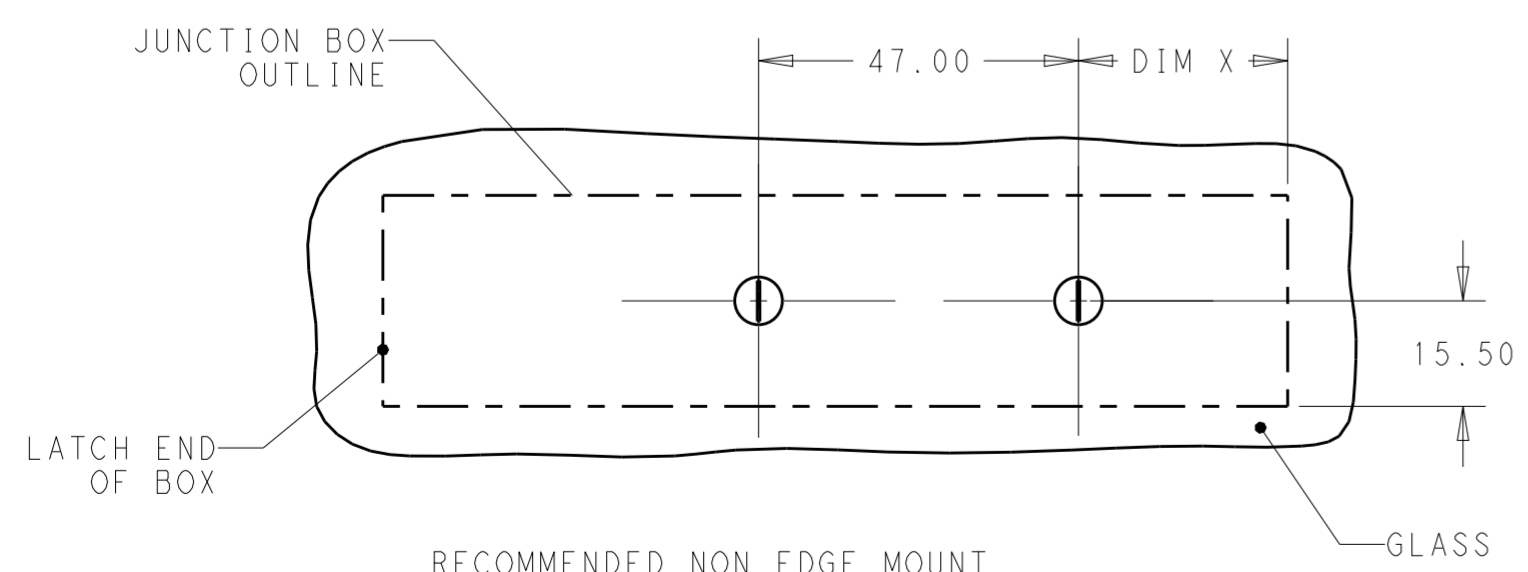

RECOMMENDED NON EDGE MOUNT (EAST-WEST PV PANEL FOIL ORIENTATION)

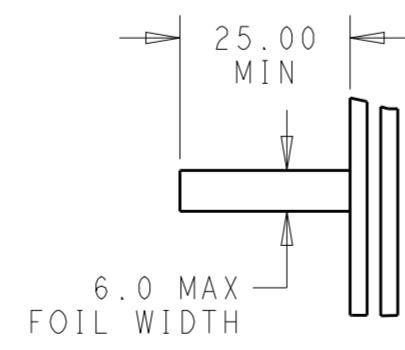

THIS DRAWING IS A CONTROLLED DOCUMENT.		DWN RAVLS 13AUG2016	TE Connectivity	
DIMENSIONS: mm		CHK GINGRICH CHUCK 13AUG2016		
TOLERANCES UNLESS OTHERWISE SPECIFIED:		APVD GINGRICH CHUCK 13AUG2016	NAME PV EDGE ASSEMBLY, WITHOUT FLAP, OMEGA CLIP	
0 PLC ±0.50		PRODUCT SPEC 108-32122	RESTRICTED TO	
1 PLC ±0.25		APPLICATION SPEC 114-32157	SIZE A2	CAGE CODE C-2306317
2 PLC ±0.13		WEIGHT -	SCALE 5:1	SHEET 4 OF 4
3 PLC ±		CUSTOMER DRAWING	REV A	
4 PLC ±				
ANGLES ±				
FINISH -				