

## PmodHB5™ Reference Manual

Revised April 12, 2016

This manual applies to the PmodHB5 rev. E

### Overview

The Digilent PmodHB5 offers a 2A H-bridge circuit to drive small to medium sized DC motors. This module was specifically designed to work with the Digilent gearbox motor, which incorporates quadrature encoder feedback.

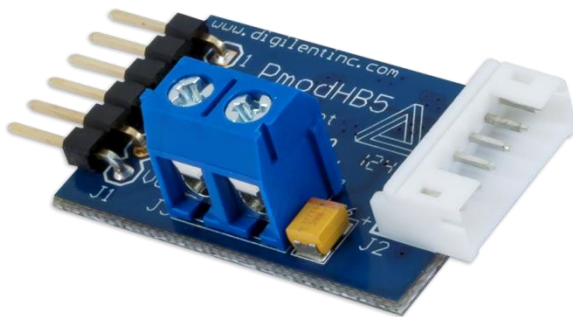

*The PmodHB5.*

Features include:

- 2A H-bridge circuit
- Drive a DC motor with operating voltage up to 12V
- 6-pin JST connector for direct connection to Digilent motor/gearboxes
- Two screw terminals for external motor power supply
- Small PCB size for flexible designs 1.2 in × 0.8 in (3.0 cm × 2.0 cm)
- 6-pin Pmod port with GPIO interface
- Follows Digilent Pmod Interface Specification Type 5
- Libraries and example code available in [resource center](#)

## 1 Functional Description

The PmodHB5 utilizes a full H-Bridge circuit to allow users to drive DC motors from the system board. Two sensor feedback pins are incorporated into the motor connection header and are specifically designed to work with the Digilent motor/gearbox.

## 2 Interfacing with the Pmod

The PmodHB5 communicates with the host board via the GPIO protocol. Like all H-Bridges, care must be taken to avoid causing a potential short within the circuitry. In terms of this Pmod, this means that the Direction pin must not change state while the Enable pin is at a high voltage state. If this does occur, one set of switches that are driving the motor will be closing while the other set is opening, allowing for the possibility for both sets of switches to be open at the same time, creating a short.

To drive the motor at a specific speed, users will need to choose a static direction (forwards or backwards corresponding to high or low voltage) on the Direction pin, and then perform pulse width modulation on the Enable pin. The more often that an enable pin is driven high within a set time frame, the faster the DC motor will spin.

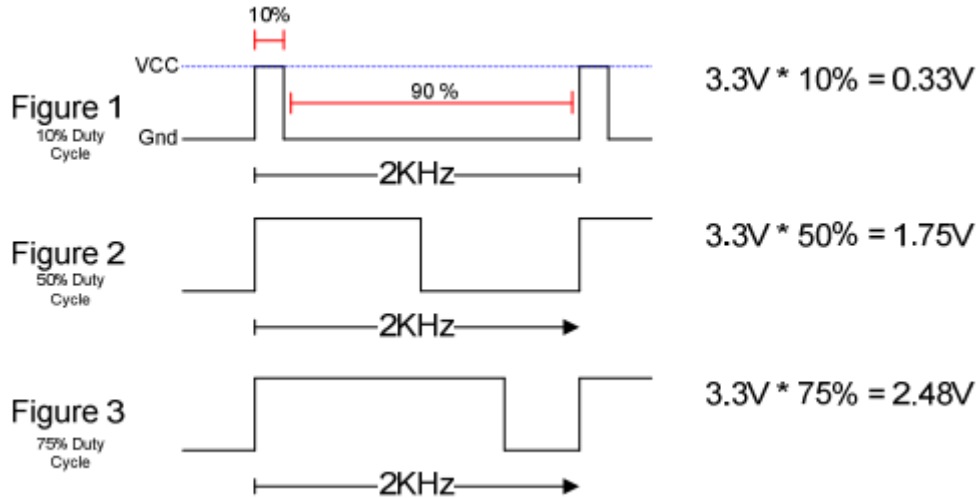

The way that this works is that when voltage is being applied, the motor is driven by the changing magnetic forces. When voltage is stopped, momentum causes the motor to continue spinning a while. At a high enough frequency, this process of powering and coasting enables the motor to achieve a smooth rotation that can easily be controlled through digital logic.

Header J1 (pin 1 on the top)			Header J2 (pin 1 on the bottom)		
Pin	Signal	Description	Pin	Signal	Description
1	DIR	Direction pin	1	SB	Sensor B feedback pin
2	EN	Enable pin	2	SA	Sensor A feedback pin
3	SA	Sensor A feedback pin	3	GND	Power Supply Ground
4	SB	Sensor B feedback pin	4	VCC	Positive Power Supply (3.3/5V)
5	GND	Power Supply Ground	5	M+	Motor positive pin
6	VCC	Positive Power Supply (3.3/5V)	6	M-	Motor negative pin

Table 1. Pinout description table.

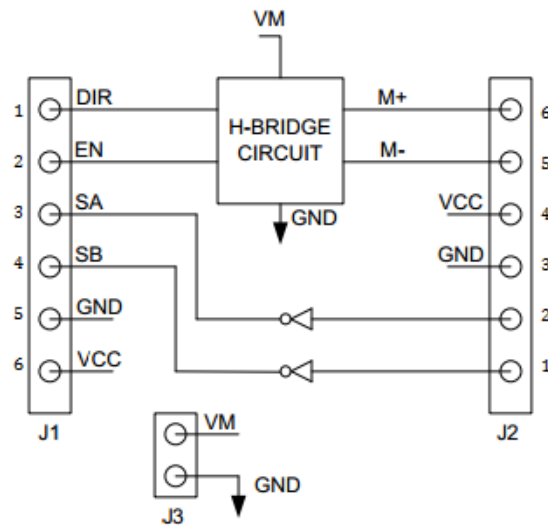

PmodHB5 block diagram (top-down view)

Any external power applied to the PmodHB5 must be within 2.7V and 5.25V; however, it is recommended that Pmod is operated at 3.3V.

### 3 Physical Dimensions

The pins on the pin header are spaced 100 mil apart. The PCB is 1.2 inches long on the sides parallel to the pins on the pin header and 0.8 inches long on the sides perpendicular to the pin header.