

UNCONTROLLED DOCUMENT

PART NUMBER		REV.
SSI-LXR5020ID-12V		D
REV.	E.C.N. NUMBER AND REVISION COMMENTS	DATE
A	ADDED NOTE #3.	9.14.92
B	SUBTRACTED NOTE #3.	5.16.95
C	E.C.N. #10BRDR. & REDRAWN.	6.10.99
D	E.C.N. #10BRDR. & REDRAWN.	8.14.01

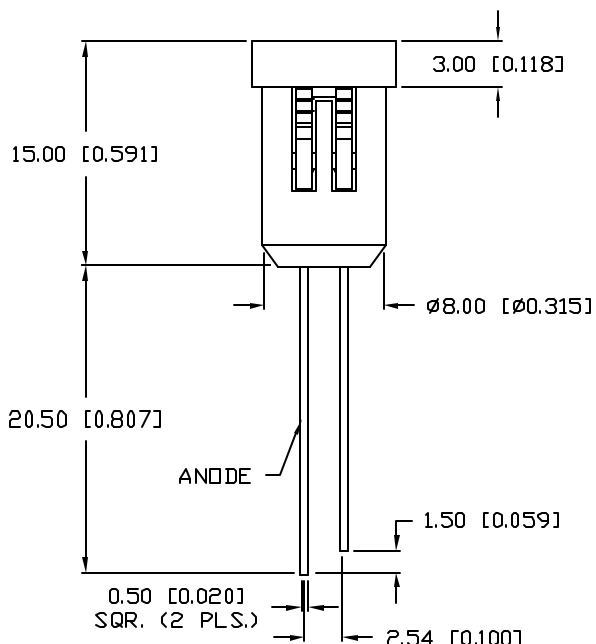
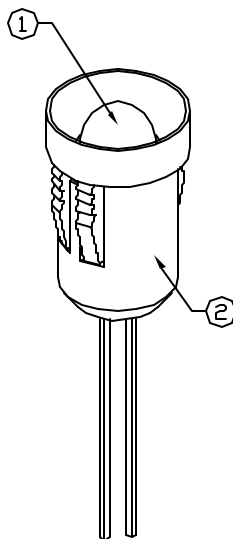
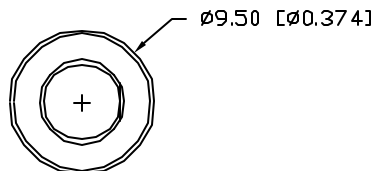

PANEL CUTOUT: 8.05mm.
PANEL THICKNESS: 0.6-2.6mm

ELECTRO-OPTICAL CHARACTERISTICS $T_A=25^{\circ}\text{C}$ $V_f=12\text{V}$

PARAMETER	MIN	TYP	MAX	UNITS	TEST COND
PEAK WAVELENGTH		635		nm	
FORWARD VOLTAGE		12.0	14.0	V_f	
REVERSE VOLTAGE	5.0			V_r	$I_r=100\mu\text{A}$
AXIAL INTENSITY		15		med	$V_f=12\text{V}$
VIEWING ANGLE		60		2x theta	
EMITTED COLOR:	RED				
EPOXY LENS FINISH:	RED DIFFUSED				

LIMITS OF SAFE OPERATION AT 25°C

PARAMETER	MAX	UNITS
PEAK FORWARD CURRENT*	150	mA
STEADY CURRENT	11	mA
POWER DISSIPATION	310	mW
DERATE FROM 25°C	-1.2	mW/°C
OPERATING, STORAGE TEMP.	-40 TO +85	°C
SOLDERING TEMP.	+260	°C
2.0mm FROM BODY		3 SEC. MAX

* $t < 10\mu\text{s}$

NOTES:

- SSL-LX5003ID-12V LED.
- SSH-RTF5020 HOLDER.

CAUTION: PRESSURE SENSITIVE ASSEMBLY
AVOID APPLYING PRESSURE TO LED
DURING PANEL ASSEMBLY.

UNCONTROLLED DOCUMENT

*UNLESS OTHERWISE SPECIFIED TOLERANCES PER DECIMAL PRECISION ARE: X=±1 (±0.039), XX=±0.5 (±0.020), XXX=±0.25 (±0.010), XXXX=±0.127 (±0.005). LEAD SIZE=±0.05 (±0.002), LEAD LENGTH=±0.75 (±0.030), MIN= ^{+0.00}/_{-0.00} DECIMAL PRECISION, MAX= ^{+0.00}/_{-0.00} DECIMAL PRECISION

REV. D	PART NUMBER SSI-LXR5020ID-12V	<p>CONFIDENTIAL INFORMATION</p> <p>THE INFORMATION CONTAINED IN THIS DOCUMENT IS THE PROPERTY OF LUMEX INC. EXCEPT AS SPECIFICALLY AUTHORIZED IN WRITING BY LUMEX INC., THE HOLDER OF THIS DOCUMENT SHALL KEEP ALL INFORMATION CONTAINED HEREIN CONFIDENTIAL AND SHALL PROTECT SAME IN WHOLE OR IN PART FROM DISCLOSURE AND DISSEMINATION TO ALL THIRD PARTIES.</p> <p>RELIABILITY NOTE</p> <p>OUR MANY YEARS OF EXPERIENCE DATA ACCUMULATION INDICATE THAT SOLDER HEAT IS A MAJOR CAUSE OF EARLY AND FUTURE FAILURE. PLEASE PAY ATTENTION TO YOUR SOLDERING PROCESS.</p>	 <p>290 E. HELEN ROAD PALATINE, IL 60067-6976 PHONE: +1.847.359.2790 US WEB: www.lumex.com TW WEB: www.lumex.com.tw</p>
T-5mm (T-1 3/4) ROUND LED PANEL INDICATOR, 635nm RED LED, RED DIFFUSED LENS, 12 VOLTS.		<p>DRAWN BY: gt</p> <p>CHECKED BY:</p> <p>APPROVED BY:</p>	<p>DATE: 9.4.92</p> <p>PAGE: 1 OF 1</p> <p>SCALE: N/A</p>