

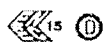

THIS INFORMATION IS CONFIDENTIAL AND PROPRIETARY TO CW INDUSTRIES INCORPORATED AND ITS AFFILIATES. IT MAY NOT BE DISCLOSED TO ANYONE, OTHER THAN CW INDUSTRIES PERSONNEL, WITHOUT WRITTEN AUTHORIZATION FROM CW INDUSTRIES INCORPORATED, SOUTHAMPTON, PENNSYLVANIA USA.

Rating	16(4)A 250V AC  		Mounting Hole	Circuit
	Contact Resistance	50m ohm Max.		
	Insulation Resistance	DC 500V 100M ohm Min.		
	Dielectric Strength	AC 1500V 1 minute		
	Switch Function	4P DPST ON-OFF		
	Operation Temp.	0° C ~ 85° C		

MATERIAL:

Frame: Nylon 66, Black UL Flame: 94-V2

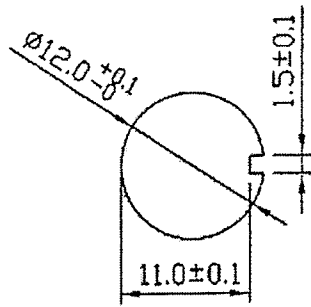
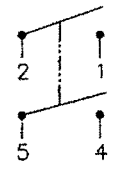
Lever: Metal

Cover: PA#66+30%GF A0520

UL Flame: 94-V0

Terminal: Copper Alloy

Contact: Copper Alloy

Waterproof: IP56

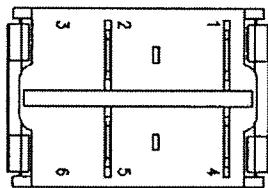
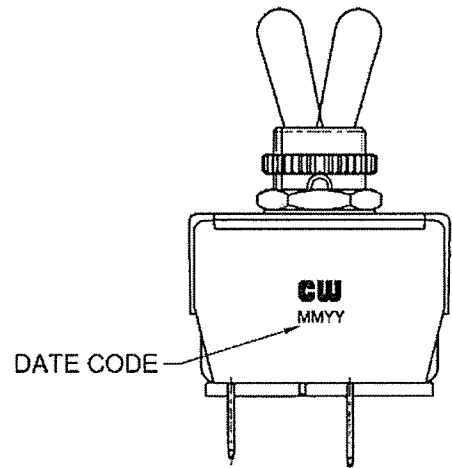
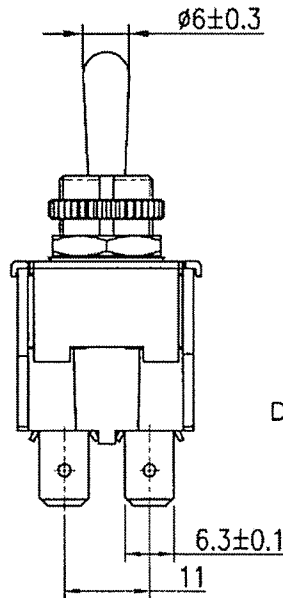
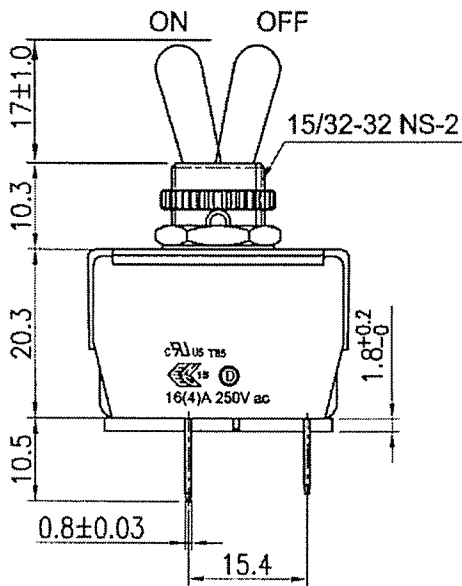
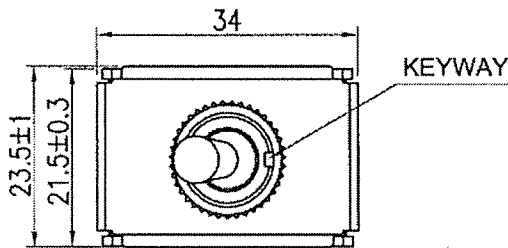

Tolerances Unless Otherwise Specified +/-0.5.

RoHS Compliant

CW INDUSTRIES
Southampton, Pa. 18966
Tel 215.355.7080/www.cwind.com

Date Drawn: 8/09/12

Rev. 0

Unit: mm

Checked By: *G. Gold*

Title: TOGGLE SWITCH

CW P/N: GTS448F101AHR