

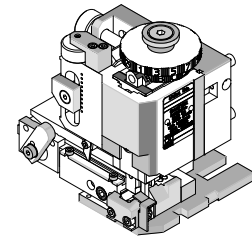

**FineAdjust
Applicator**

**Application Tooling
Specification Sheet**



Order No. 63868-8100

FEATURES

- Directly adapts to most automatic wire processing machines
- Quick punch removal with the push of a button for fast and easy tooling change
- Applicator designed to industry standard mounting and shut height 135.80mm (5.346")
- Quick set-up time; plus the crimp height, track and feed adjustments can be set without removing the applicator from the press
- Fine adjustment allows users to achieve target with little effort by adjusting in increments of .015mm (.0006") for conductor crimp height and .063mm (.0025") for insulation height
- Independent adjustment rings allow users to quickly adjust the conductor or insulation crimp height without affecting each other

SCOPE

Products: 1.50mm (.059") CP Crimp Terminal for CMC connector, 1.40-2.00mm².

Terminal Series No.	Terminal Order No.	Wire Size		Insulation Type	Insulation Diameter		Strip Length	
		AWG	mm ²		mm	In.	mm	In.
98915	98915-1039	---	2.00	IR	2.50-2.70	.098-.106	4.50	.177
	98915-1219	---	1.50	IR and ID	2.10-2.40	.083-.094	4.50	.177
	---	1.40	IR	2.20-2.40	.087-.094	4.50	.177	
64323	64323-1039	---	2.00	IR	2.50-2.70	.098-.106	4.50	.177
	64323-1219	---	1.50	IR and ID	2.10-2.40	.083-.094	4.50	.177
	---	1.40	IR	2.20-2.40	.087-.094	4.50	.177	

DEFINITION OF TERMS

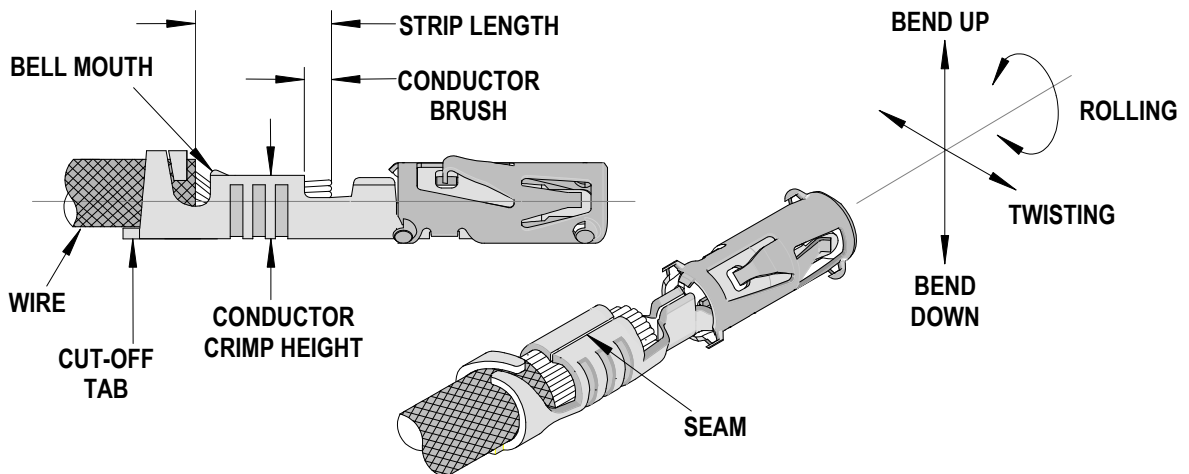

CRIMP SPECIFICATION

Terminal Series No.	Bell mouth		Cut-off Tab Maximum		Conductor Brush	
	mm	In.	mm	In.	mm	In.
98915	0.00-0.30	.000-.012	0.30	.012	0.20-0.80	.008-.031
64323	0.00-0.30	.000-.012	0.30	.012	0.20-0.80	.008-.031

Terminal Series No.	Bend up	Bend down	Twist	Roll	Punch Width (Ref)				Seam Seam shall not be open and no wire allowed out of the crimping area
					Conductor		Insulation		
	Degree Maximum		Degree Maximum		mm	In	mm	In	
98915	1	1	1	2	2.20	.087	2.80	.110	
64323	1	1	1	2	2.20	.087	2.80	.110	

After crimping, the conductor profile should measure the following.

Terminal Series No.	Wire Size		Conductor Crimp Height		Insulation Crimp Height (Ref.)		Pull Force Minimum	
	AWG	MM ²	mm	In.	mm	In.	N	Lb.
98915	---	2.00	1.70-1.80	.067-.071	2.75-2.90	.108-.114	195.0	43.90
	---	1.50	1.50-1.60	.059-.063	2.50-2.75	.098-.108	155.0	34.90
	---	1.40	1.45-1.55	.057-.061	2.55-2.70	.100-.106	150.0	33.75
64323	---	2.00	1.70-1.80	.067-.071	2.75-2.90	.108-.114	195.0	43.90
	---	1.50	1.50-1.60	.059-.063	2.50-2.75	.098-.108	155.0	34.90
	---	1.40	1.45-1.55	.057-.061	2.55-2.70	.100-.106	150.0	33.75

*** Tool Qualification Notes:**

1. Pull Force should be measured with no influence from the insulation crimp.
2. The above specifications are guidelines to an optimum crimp.

PARTS LIST

FineAdjust Applicator 63868-8100				
Item	Order No	Engineering No.	Description	Quantity
Perishable Tooling				
	63868-8170	63868-8170	Tool Kit (All "Y" Items)	REF
1	63457-0032	63457-0032	Conductor Punch	1 Y
2	63455-0036	63455-0036	Conductor Anvil	1 Y
3	63454-0057	63454-0057	Insulation Punch	1 Y
4	63456-0037	63456-0037	Insulation Anvil	1 Y
5	63443-0035	63443-0035	Cut-Off Plunger	1 Y
6	63443-0036	63443-0036	Front Plunger Retainer	1 Y
Other Components (688150)				
7	11-17-0022	1739-21	Hold Down Spring	1
8	11-18-4083	60707-8	Feed Guide	1
9	11-24-1149	4996-37	Shank	1
10	63443-0009	63443-0009	Scrape Chute	1
11	63443-0024	63443-0024	Key	1
12	63443-0090	63443-0090	Wire Stop	1
13	63443-1717	63443-1717	Height Spacer	1
14	63443-2214	63443-2214	Course Spacer (14.0mm)	1
15	63443-2307	63443-2307	Fine Spacer (3.35mm)	1
16	63443-3160	63443-3160	Front Plunger Striker	1
17	63443-6121	63443-6121	Rear Cover	1
18	63443-7002	63443-7002	Terminal Hold Down	1
19	63700-0539	63700-0539	Cut-off Plunger Spring	1
Frame				
20	63800-4901	63800-4901	Top	1
21	63801-3281	63801-3281	Base	1
22	63801-4650	63801-4650	Track	1
Hardware				
23	N/A	N/A	M3 by 6 Long SHCS	2**
24	N/A	N/A	M3 by 6 Long FHCS	1**
25	N/A	N/A	M4 by 6 Long SHCS	2**
26	N/A	N/A	M4 by 12 Long BHCS	2**
27	N/A	N/A	M4 by 50 Long SHCS	2**
28	N/A	N/A	M5 by 12 Long SHCS	1**
29	N/A	N/A	#5-40 by 3/8" Long SHCS	1**
30	N/A	N/A	#10-32 by 3/8" Long Flat Point SSS	1**
31	N/A	N/A	#10-32 Hex Jam Nut	1**

** Available from an industrial supply company such as MSC (1-800-645-7270).

Assembly Drawing

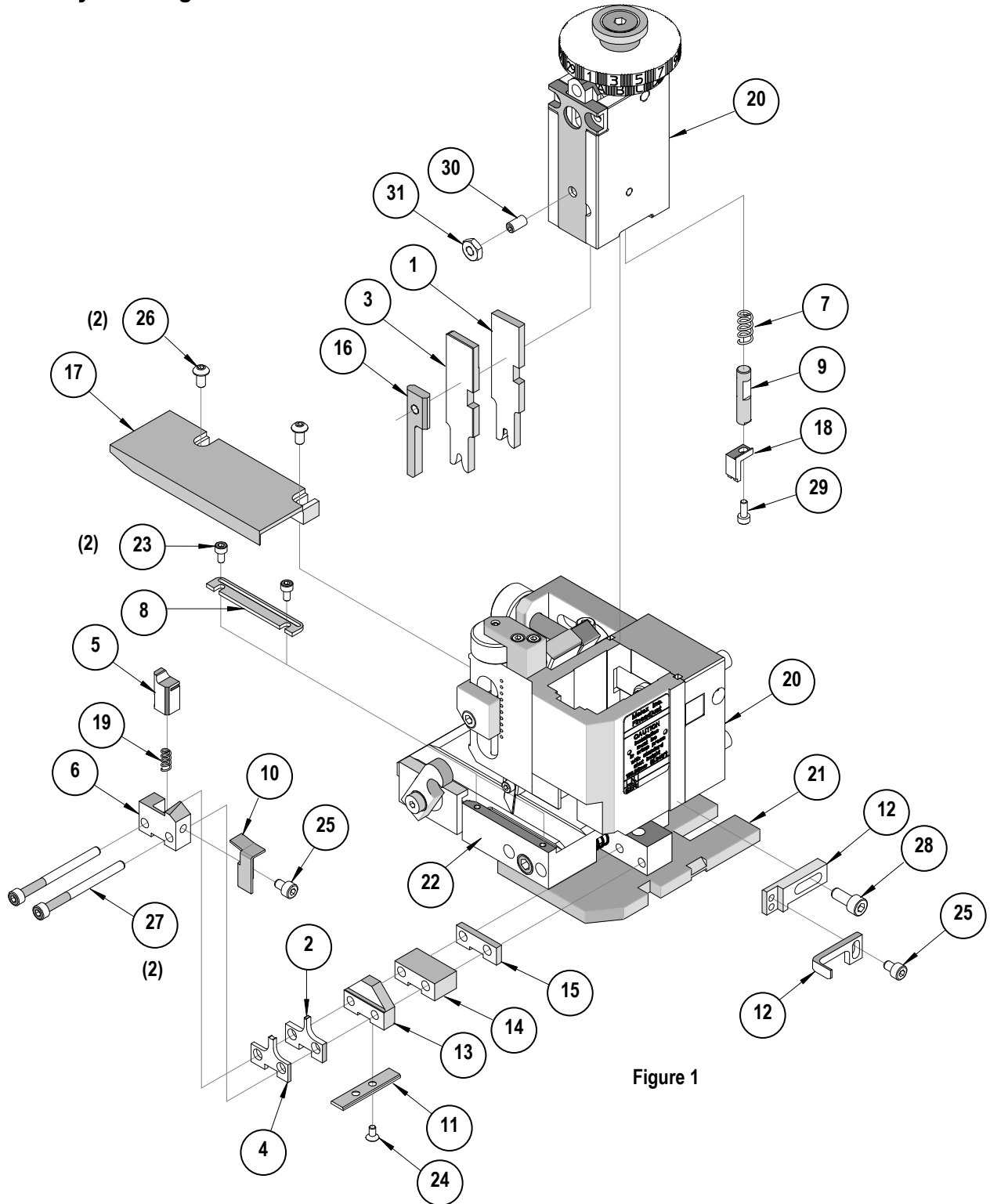

Figure 1

Optional Applicator Parts:

The following parts are *not included* with this Applicator and may be purchased separately.

63901-6106 Cut-Off Plunger Retainer

For wire processing applications:

It is recommended for fully automatic, high speed operations, where the press and the applicator are mounted to a wire processing machine.

Applicator down time for scrap clean-up may be reduced.

This cut-off plunger retainer leaves the scrap terminal carrier intact.

Not recommended for bench operation, where a continuous scrap strip can tangle or build up inside of the safety guards resulting in jams or tooling damage.

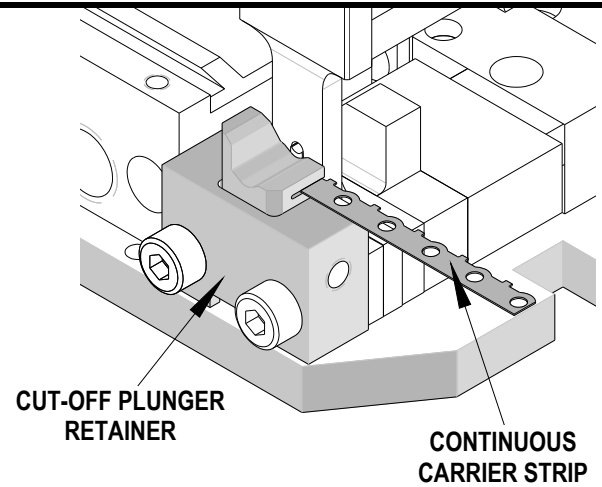

NOTES

1. Molex recommends an extra perishable tooling kit be maintained at your facility.
2. Verify tooling alignment by manually cycling the press and Applicator before crimping under power. Check that all screws are tight.
3. Slugs, Terminals, Dirt and Oil should be kept clear of work area.
4. Wear safety glasses at all times.
5. For recommended maintenance refer to the FineAdjust Manual.

CAUTION: This applicator should only be used in a press with a shut height of 135.8mm (5.346"). Tooling damage could result at a lower setting.

CAUTION: To prevent injury never operate this Applicator without the guards supplied with the press or wire-processing machine in place. Reference the press or wire processing manufacturer's instruction manual.

CAUTION: Molex crimp specifications are valid only when used with Molex terminals, applicators and tooling.

<http://www.molex.com>