

THIS DRAWING IS UNPUBLISHED. RELEASED FOR PUBLICATION  
 © COPYRIGHT - By - ALL RIGHTS RESERVED.

LOC		DIST		REVISIONS			
P	LTR	DESCRIPTION		DATE	DWN	APVD	
	T	REVISED PER ECO-14-012828		30AUG2014	MGM	CT	

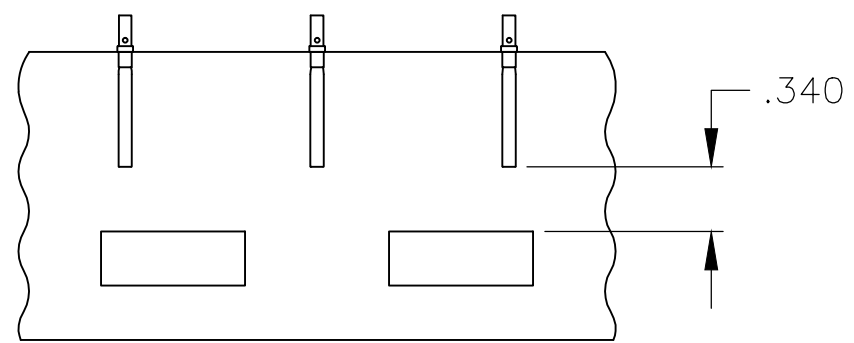

DETAIL A  
 TAPE MOUNTED  
 ASSEMBLY  
 SCALE 1:1  
 205116-2 ONLY

- WHEN ORDERING CONTACT ON TAPE, ORDER BY THE TAPE NUMBER PLUS THE PACKAGING CODE AS FOLLOWS:
  - FOR USE WITH AMP TAPETRONIC, PNEUMATIC TOOL-
    - 1000 PARTS TO A BOX ADD PACKAGING CODE: 1MBOX
  - FOR USE WITH 4/8 INDENT STRIPPER CRIMPER-
    - 1000 PARTS TO A REEL ADD PACKAGING CODE: 1MREEL
    - 5000 PARTS TO A REEL ADD PACKAGING CODE: 5MREEL
- POINT OF PLATING THICKNESS MEASUREMENT .100/.150 FROM WIRE BARREL END ON EXTERIOR.
- MANUFACTURER'S LOGO ("A" OR "-.") LOCATION OPTIONAL.

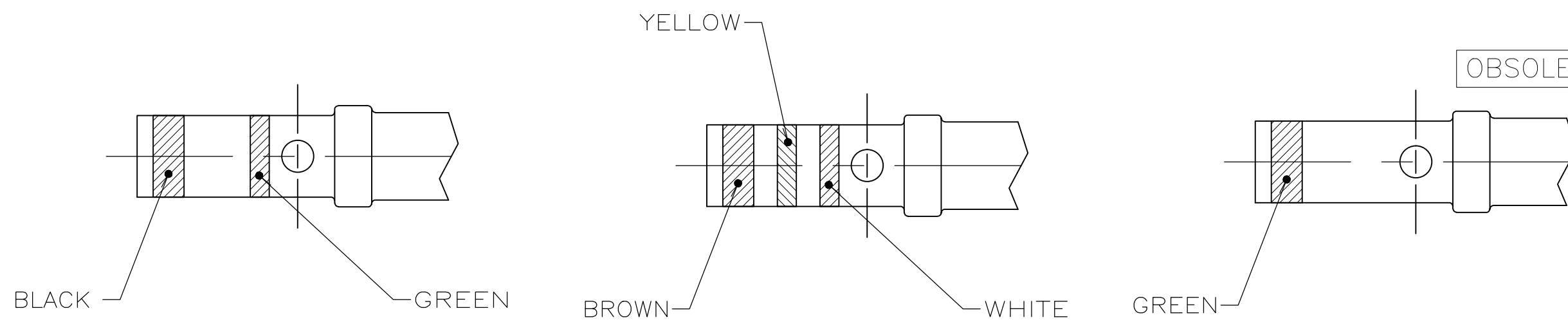
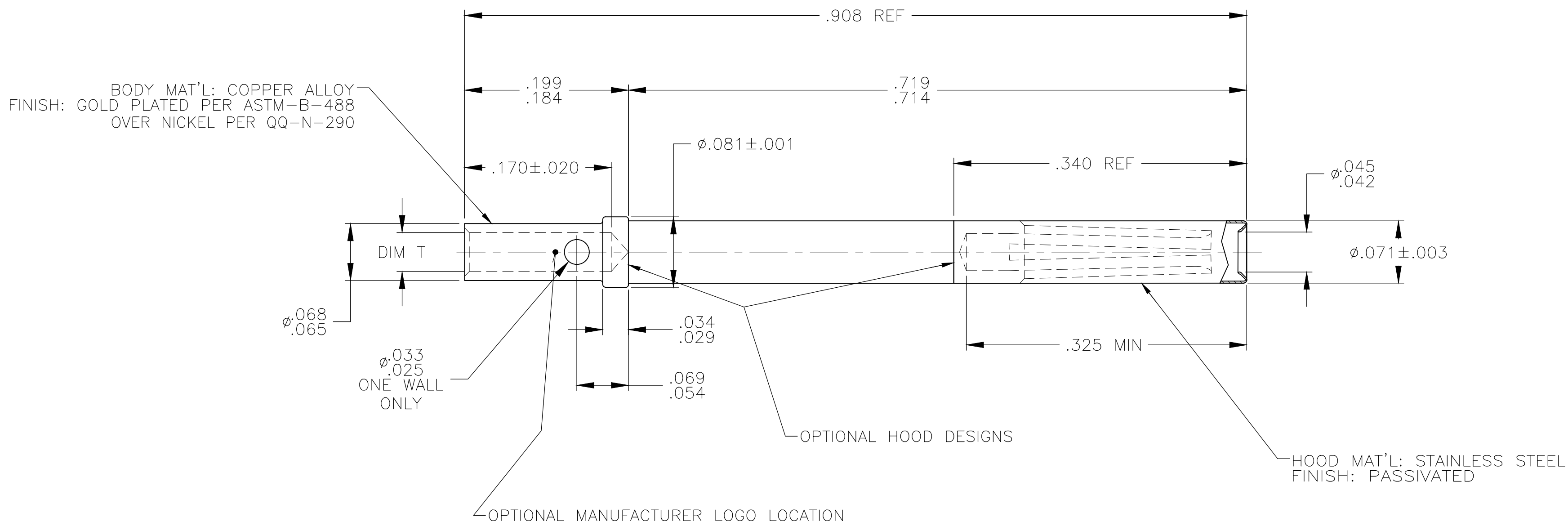

DETAIL D  
 205116-5 ONLY

DETAIL B  
 205116-1 & -2 ONLY

DETAIL C  
 205116-4 ONLY

OBSOLETE

WIRE GAGE	REMARKS	DIM T	PART NUMBER
30 - 26	SEE DETAIL D	ø.023-.025	205116-5
24 - 20	SEE DETAIL C	ø.043-.046	205116-4
24 - 20	NO COLOR CODE	ø.043-.046	205116-3
24 - 20	SEE DETAIL A & B	ø.043-.046	205116-2
24 - 20	SEE DETAIL B	ø.043-.046	205116-1

THIS DRAWING IS A CONTROLLED DOCUMENT. DIMENSIONING AND TOLERANCING PER ASME Y14.5M (ISO STANDARDS)		DWN C.C.THOMAS 2-12-04	TE Connectivity	
DIMENSIONS: INCHES		CHK LARRY OH 2-12-04		
TOLERANCES UNLESS OTHERWISE SPECIFIED:		APVD LARRY OH 2-12-04	NAME	
0 PLC ± -	1 PLC ± -	PRODUCT SPEC	SOCKET ASSEMBLY,SUB 20,TYPE XVII-RM	
2 PLC ± -	3 PLC ± .005	APPLICATION SPEC	SIZE	CAGE CODE
4 PLC ± -	ANGLES ± 2°	WEIGHT	A2	00779
MATERIAL SEE CALLOUTS	FINISH SEE CALLOUTS	CUSTOMER DRAWING	DRAWING NO	RESTRICTED TO
			C=205116	-
			SCALE 10:1	SHEET 1 OF 1
			REV T	