

DATE	SYM	REVISION RECORD	AUTH.	DR.	CK.
12/2/98	-	ISSUED		NT	GH
6/26/01	C	UPDATE		NT	DG
4/29/02	C1	UPDATE PLATING SPEC.		NT	DG

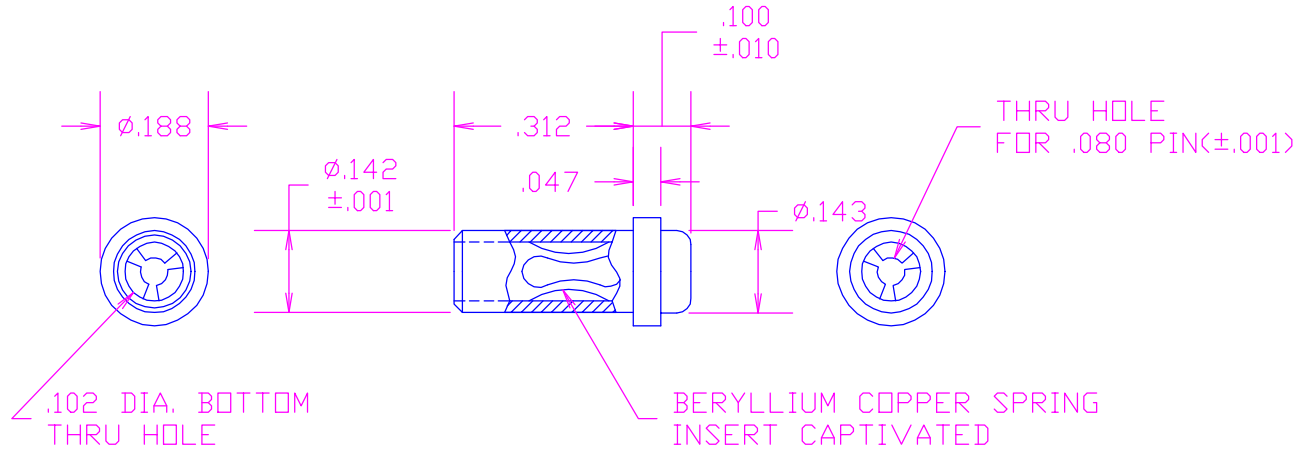

RECOMMENDED MOUNTING HOLE .144±.001 DIA.

FINISH CODE	COMPONENT	MATERIAL	FINISH
03	BODY	BRASS PER ASTM B16	.000010" GOLD PER ASTM B 488 , TYPE 3, CODE C, OVER .0001" NICKEL PER AMS-QQ-N-290
	SPRING	BERYLLIUM COPPER PER ASTM B194	.000030" GOLD PER ASTM B 488, TYPE 3, CODE C OVER .0001" NICKEL PER AMS-QQ-N-290
04	BODY	BRASS PER ASTM B16	.0001" ELECTRO-TIN PER MIL-T-1027 OVER .0001" NICKEL
	SPRING	BERYLLIUM COPPER PER ASTM B194	.0002" BRIGHT ELECTRO-TIN PER MIL-T-1027 , TYPE I OVER .000050" NICKEL
06	BODY	BRASS PER ASTM B16	.0001" ELECTRO-TIN PER MIL-T-1027 OVER .0001" NICKEL
	SPRING	BERYLLIUM COPPER PER ASTM B194	.000030" GOLD PER ASTM B 488, TYPE 3, CODE C OVER .0001" NICKEL PER AMS-Q-N-290

ACTUAL SIZE



TOLERANCES (EXCEPT AS NOTED)	CONCORD ELECTRONICS CORPORATION		
DECIMAL + .010 - .010	P/N	SCALE 3:1	30 GREAT JONES ST. NEW YORK N.Y. 10012
FRACTIONAL + 1/64 - 1/64	TITLE P.C.JACK FOR .080 PIN		
ANGULAR + -	DATE 4-18-96	DRAWING NUMBER 09-9044-1-XX	