

THIS DRAWING IS UNPUBLISHED. RELEASED FOR PUBLICATION 20
 © COPYRIGHT 20 BY - ALL RIGHTS RESERVED.

LOC	DIST	REVISIONS			
P	LTR	DESCRIPTION	DATE	DWN	APVD
DF	A5	D	RELEASED	6-27-12	CT DM
				25OCT2011	KG DM

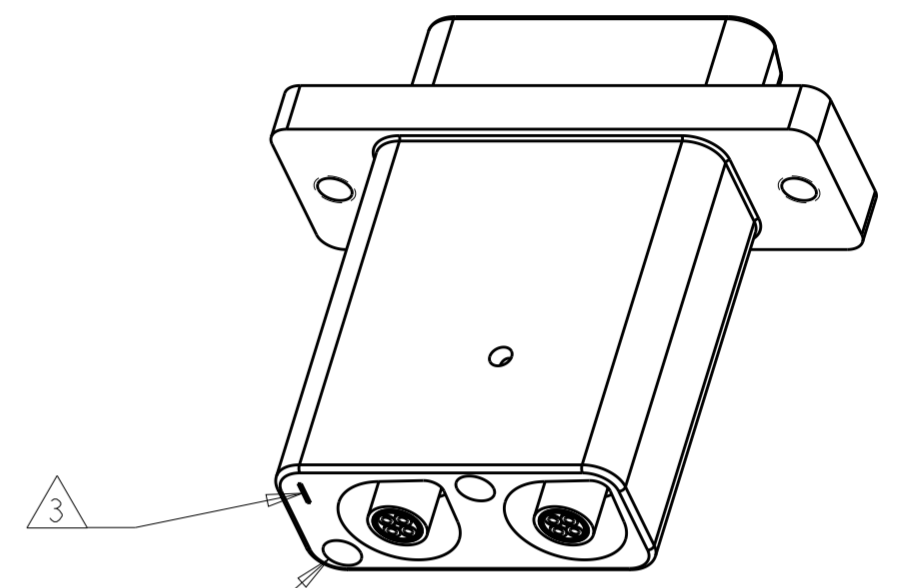

2X 2-56UNC-2B SPIRALOCK THREAD

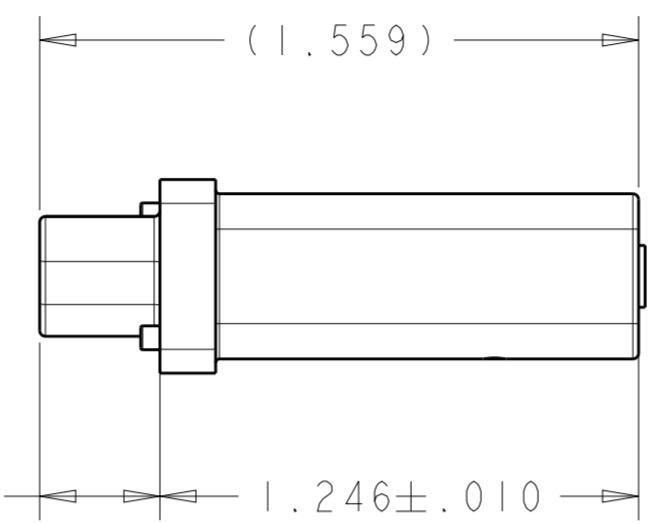
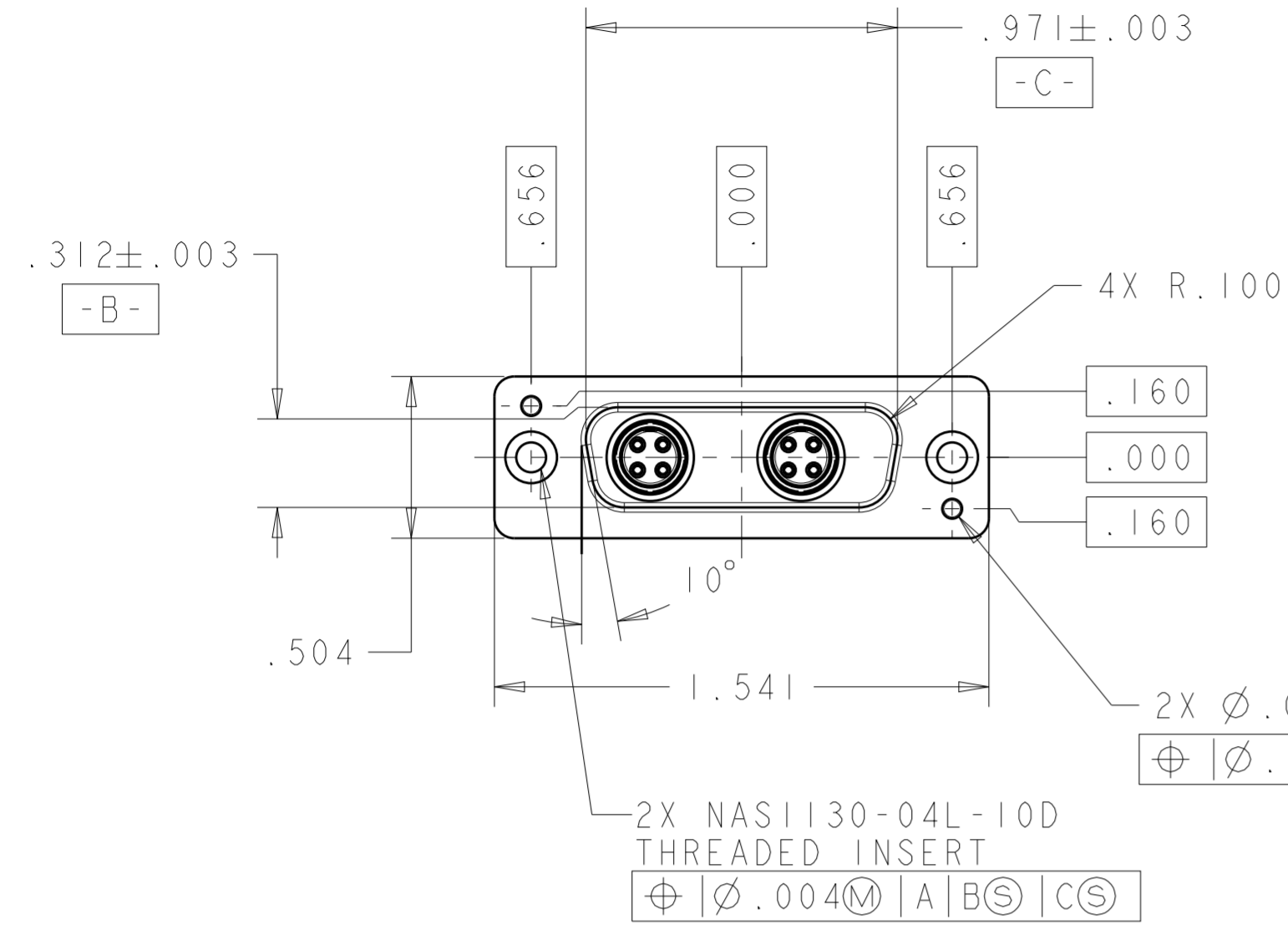
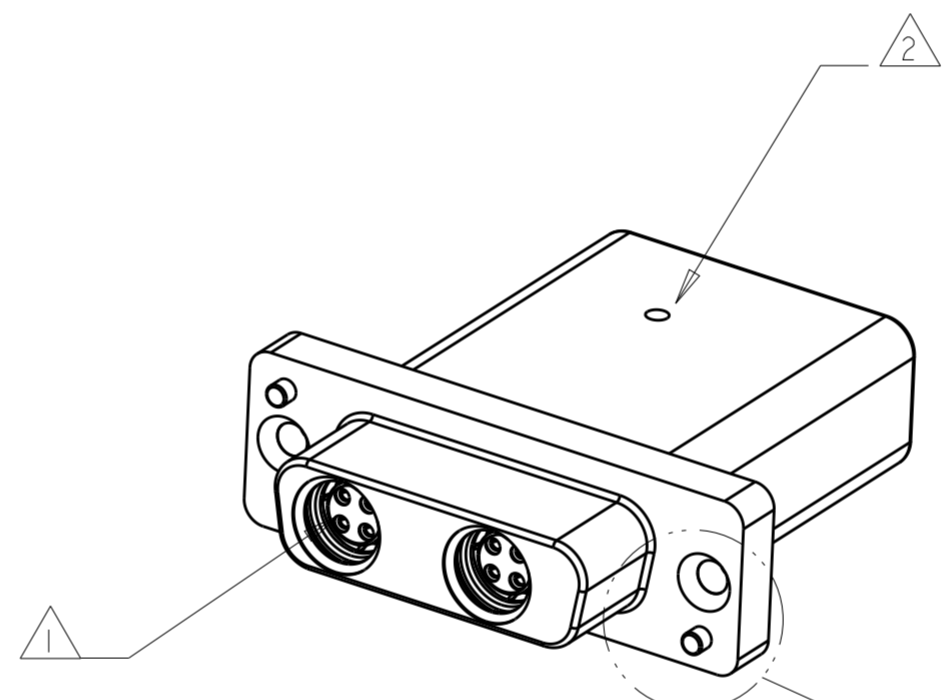
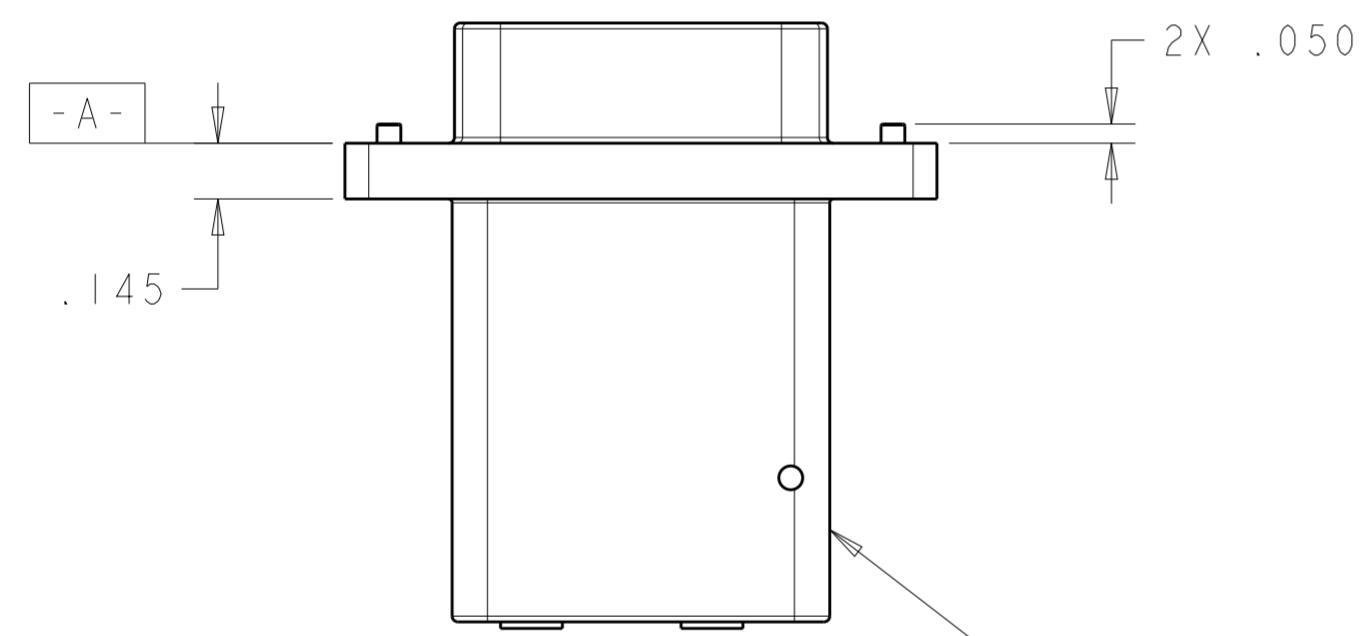

CONTACT TE CONNECTIVITY FOR STANDARD HARDWARE FOR CONNECTOR ATTACHMENT

SHELL
 ELECTROLESS NICKEL PLATED PER AMS-C-26074 CLASS 1
 ALUMINUM ALLOY 6061-T6 PER ASTM B221
 CONTACT RETENTION CLIP QTY = 2 (ASSEMBLED INSIDE SHELL)
 STAINLESS STEEL PER UNS S30200 PER ASTM A666
 PLATED SILVER .000400 MIN THICK PER ASTM B700 OVER WOODS
 NICKEL STRIKE PER ASTM B254

2157449-1
 PART NUMBER

- 1 CONNECTOR KIT INCLUDES QUADRAx CONTACTS (TE CONNECTIVITY PART# 1445693-3, QTY 2) FOR 100Ω CABLE. NOT INSTALLED
- 2 CONNECTOR IS MARKED WITH TE, TE CONNECTIVITY PART NUMBER & DATE CODE.
- 3 RECESSED CIRCUIT IDENTIFICATION.

THIS DRAWING IS A CONTROLLED DOCUMENT.		DWN K. GLATFELTER 24FEB2011	TE Connectivity	
DIMENSIONS: INCHES		CHK D. MILLER 24FEB2011		
TOLERANCES UNLESS OTHERWISE SPECIFIED:		APVD D. MILLER 24FEB2011	NAME QUADRAx 202 ASSY, PLUG, D-SUB, SIZE 2	
0 PLC ± 1 PLC ± 2 PLC ±.01 3 PLC ±.005 4 PLC ± ANGLES ± FINISH		PRODUCT SPEC - APPLICATION SPEC -	SIZE A200779	CAGE CODE C-2157449
MATERIAL		WEIGHT -	DRAWING NO C-2157449	RESTRICTED TO -
		CUSTOMER DRAWING	SCALE 2:1	SHEET 1 OF 1