

Model TS318-1B0814 Thermopile Sensor



Thermopile IR-Sensor
For Contactless Temperature Measurement
Single Element
Small Package for Ear Thermometer
High Signal
Flat Filter
Accurate Reference Sensor

DESCRIPTION

Thermopiles are mainly used for contactless temperature measurement in many applications. Their function is to transfer the heat radiation emitted from the objects into a voltage output.

FEATURES

- High Signal
- Ni-RTD Reference Sensor
- Small TO-18 Package
- 8-14 μ m Band Pass Filter for measurement distances >0.5m

APPLICATIONS

- Pyrometers (general)
- Industrial Pyrometers

ABSOLUTE MAXIMUM RATINGS

Parameter	Symbol	Min	Typical	Max	Unit	Description
Storage Temperature	T _s	-20	+20	+85	°C	permanent
Storage Temperature	T _s	-20	+20	+100	°C	non permanent

Model TS318-1B0814 Thermopile Sensor

PERFORMANCE SPECS

Parameter	Symbol	Value	Unit	Condition
Operating Ambient Temperature	T_{Amb}	-20 to +85	°C	permanent
Operating Ambient Temperature	T_{Amb}	-20 to +100	°C	non permanent
Package		TO-18		
Absorber Area	A	0.8×0.8	mm ²	
Thermopile Resistance	R_{TP}	70 ± 30	k Ω	$T_{Amb} = +25\text{ }^{\circ}\text{C}$
Temperature Coefficient of Thermopile Resistance	TCR_{TP}	-0.06 ± 0.04	%/K	$T_{Amb} = +25\text{ }^{\circ}\text{C}$ to $+75\text{ }^{\circ}\text{C}$
Voltage Response	V_{TP}	5.0 ± 1.3	mV	$T_{Amb} = +25\text{ }^{\circ}\text{C}$, $T_{Obj} = +100\text{ }^{\circ}\text{C}$, DC, totally filled field of view
Temperature Coefficient of Voltage Response	TCV_{TP}	-0.45 ± 0.08	%/K	$T_{Amb} = +25\text{ }^{\circ}\text{C}$ to $+75\text{ }^{\circ}\text{C}$
Noise Equivalent Voltage	NEV	34	nV/Hz ^{1/2}	$T_{Amb} = +25\text{ }^{\circ}\text{C}$
Rise Time	τ_{63}	12 ± 5	ms	
Ambient Temperature Sensor		Ni-RTD		
Ambient Temperature Sensor Resistance	R_{Ni-RTD}	1000 ± 4	Ω	$T_{Amb} = 0\text{ }^{\circ}\text{C}$
Temperature Coefficient of Ni-RTD	TC_{Ni-RTD}	6178 ± 150	ppm/K	$T_{Amb} = 0\text{ }^{\circ}\text{C}$ to $+100\text{ }^{\circ}\text{C}$

TYPICAL PERFORMANCE CURVES

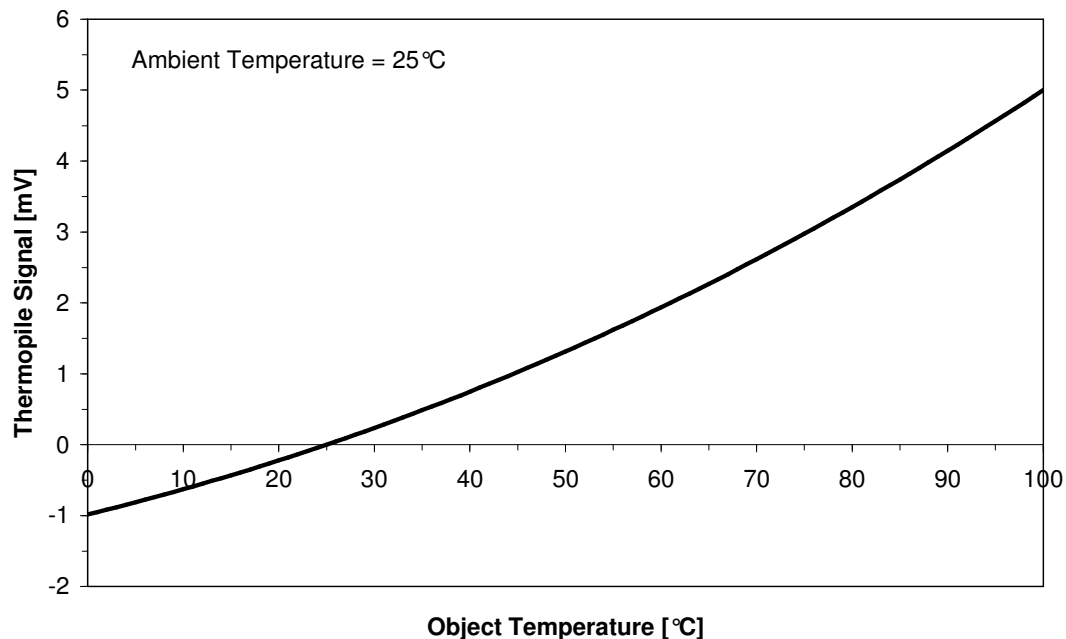

Figure 1: Thermopile signal versus object temperature at 25°C ambient temperature

Model TS318-1B0814 Thermopile Sensor

OPTICAL CHARACTERISTICS

Parameter	Symbol	Value	Unit	Description
Field of View	FOV	110	deg	at 50% of maximum signal

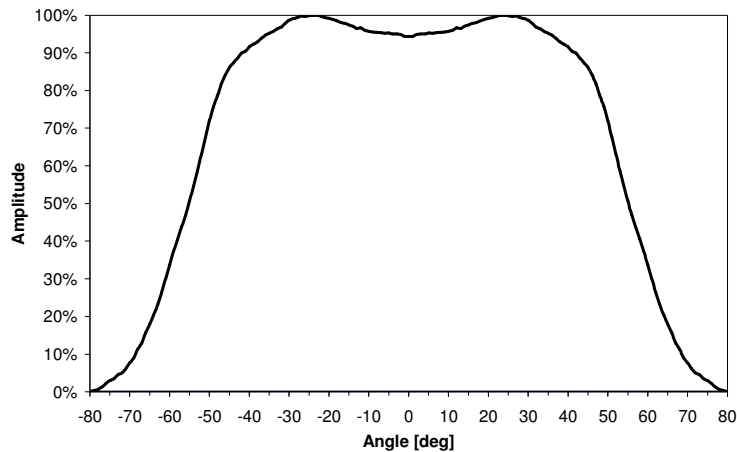

Figure 2: Field of View Curve

FILTER CHARACTERISTICS

Parameter	Symbol	Value	Unit	Description
Transmission Range	BBP	8-14	μm	Broad Band Pass
Transmission	$T_{9 \dots 13\mu\text{m}}$	≥ 75.0	%	at 9 ... 13 μm

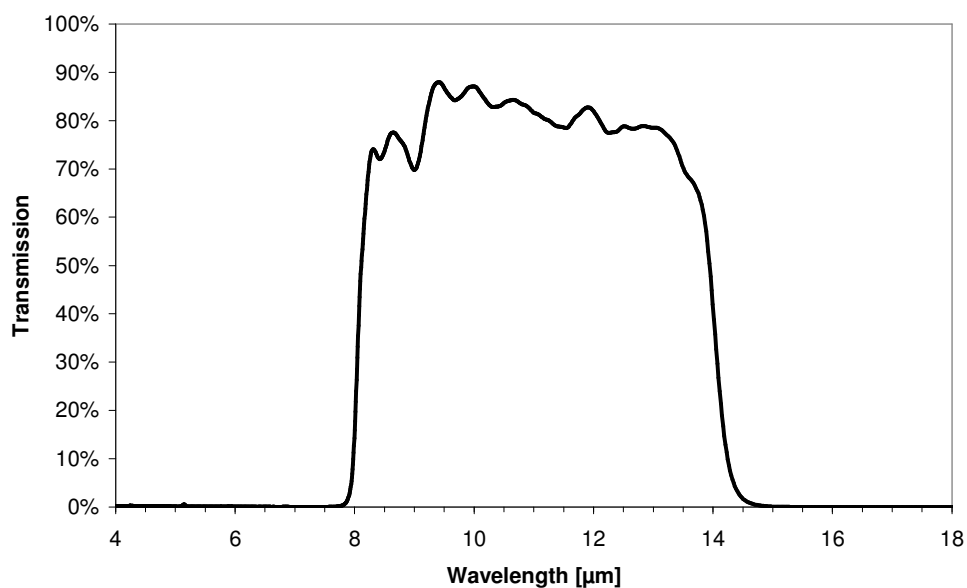

Figure 3: Filter transmission curve

Model TS318-1B0814 Thermopile Sensor

ELECTRICAL CONNECTIONS

Pin	Symbol
1	TP +
2	Ni-RTD
3	TP -
4	GND

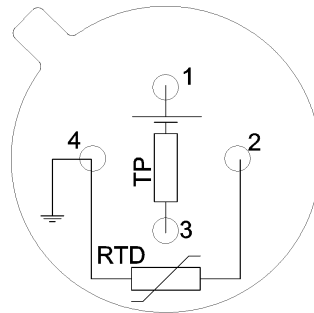
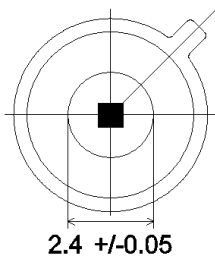

Figure 4: Electrical connections - bottom view of thermopile

MECHANICAL DIMENSIONS

TOP VIEW



SIDE VIEW

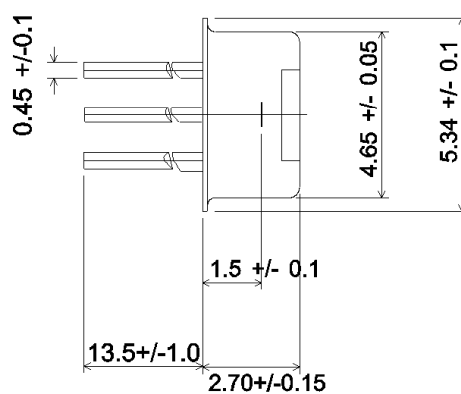

BOTTOM VIEW

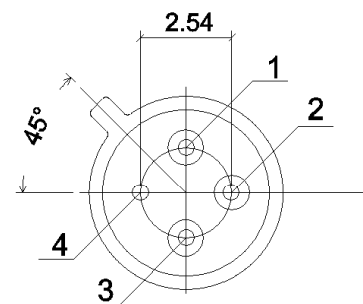

Figure 5: Mechanical dimensions of thermopile

Model TS318-1B0814 Thermopile Sensor

ORDERING INFORMATION

Part Description TS318-1B0814

Part No. G-TPCO-031

TECHNICAL CONTACT INFORMATION

NORTH AMERICA	EUROPE	ASIA
Measurement Specialties, Inc. 1000 Lucas Way Hampton, VA 23666 United States Phone: +1-800-745-8008 Fax: +1-757-766-4297 Email: sales@meas-spec.com Web: www.meas-spec.com	MEAS Deutschland GmbH Hauert 13 D-44227 Dortmund Germany Phone: +49-(0)231-9740-0 Fax: +49-(0)231-9740-20 Email: info.de@meas-spec.com Web: www.meas-spec.com	Measurement Specialties China Ltd. No. 26, Langshan Road High-tech Park (North) Nanshan District, Shenzhen 518057 China Phone: +86-755-33305088 Fax: +86-755-33305099 Email: info.cn@meas-spec.com Web: www.meas-spec.com

The information in this sheet has been carefully reviewed and is believed to be accurate; however, no responsibility is assumed for inaccuracies. Furthermore, this information does not convey to the purchaser of such devices any license under the patent rights to the manufacturer. Measurement Specialties, Inc. reserves the right to make changes without further notice to any product herein. Measurement Specialties, Inc. makes no warranty, representation or guarantee regarding the suitability of its product for any particular purpose, nor does Measurement Specialties, Inc. assume any liability arising out of the application or use of any product or circuit and specifically disclaims any and all liability, including without limitation consequential or incidental damages. Typical parameters can and do vary in different applications. All operating parameters must be validated for each customer application by customer's technical experts. Measurement Specialties, Inc. does not convey any license under its patent rights nor the rights of others.