



austriamicrosystems AG

is now

ams AG

The technical content of this austriamicrosystems application note is still valid.

Contact information:

Headquarters:

ams AG
Tobelbaderstrasse 30
8141 Unterpremstaetten, Austria
Tel: +43 (0) 3136 500 0
e-Mail: ams_sales@ams.com

Please visit our website at www.ams.com

AS5132

8 BIT PROGRAMMABLE HIGH SPEED MAGNETIC ROTARY ENCODER

AS5132-DB-1.0 Demoboard

OPERATION MANUAL

1 General Overview

The AS5132 is a contactless magnetic rotary encoder for accurate angular measurement over a full turn of 360°. It is a system-on-chip, combining integrated Hall elements, analog front end and digital signal processing in a single device.

To measure the angle, only a simple two-pole magnet, rotating over the center of the chip is required.

The absolute angle measurement provides instant indication of the magnet's angular position with a resolution of 8.5 bit = 360 positions per revolution. This digital data is available as a serial bit stream and as a PWM signal.

An additional U,V,W output can be used for a block commutation for a brushless DC motor. An incremental signal is available as an option.

In addition to the angle information, the strength of the magnetic field is also available as a 5-bit code.

A software programmable (OTP) zero position simplifies assembly as the zero position. The magnet does not need to be mechanically aligned.

To optimize the torque characteristic at a certain speed the AS5132 has the option to use a static or dynamic pre-commutation.

2 The AS5132 Demoboard

The AS5132 demoboard is a complete rotary encoder system with built-in microcontroller, USB interface, graphical LCD display, incremental indicators, commutation indicators and PWM output LED.

The board is USB powered or externally supplied with a 9V battery for standalone operation. For this Demoboard the AS5132 is configured with UVW Output.

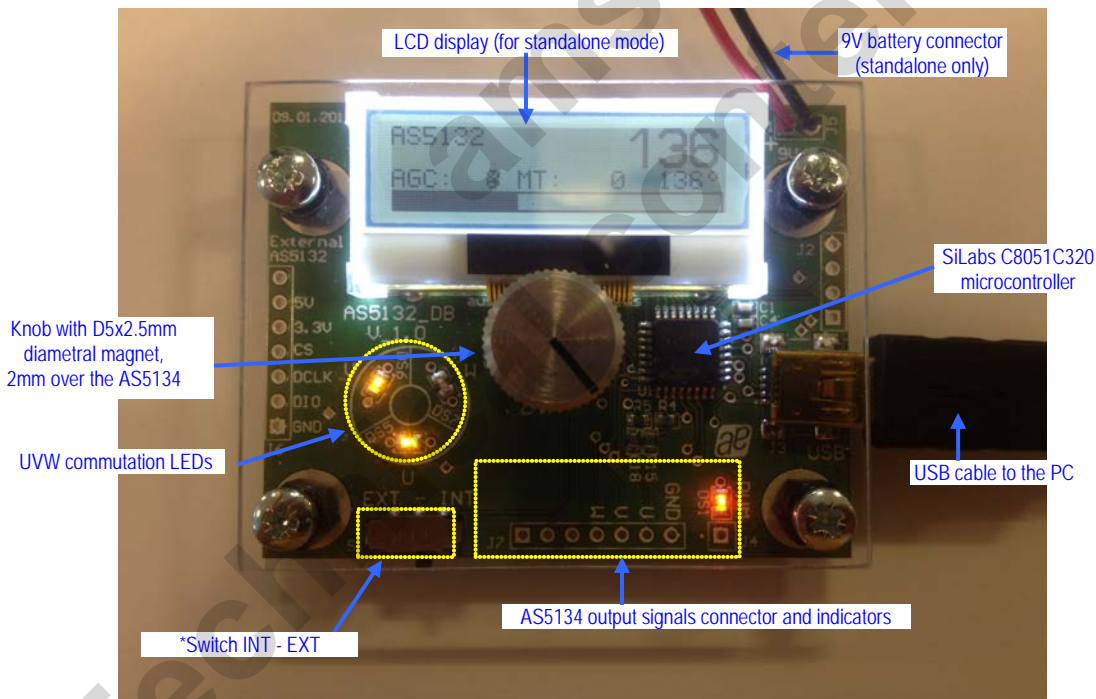

Figure 1: AS5132 Demoboard hardware with mounted magnet knob

3 Operating the AS5132 Demoboard

The AS5132 demoboard can be used in several ways:

- **As standalone unit supplied by a 9V battery**

Connect a 9V battery to the battery connector on the top right side of the board. No other connections are required.

- **As standalone unit supplied by an USB port**

Connect the demoboard to a PC using a USB/USB cable (included in demoboard shipment). The board is supplied by the 5V supply of the USB port. No other connections are required.

- **As input device for the AS5000 Programmer GUI software**

This configuration uses the same USB hardware connection as above, but additionally the AS5000 Programmer GUI software is running. The LCD display will be turned off and the Angle/Multiturn/AGC will be displayed on the PC screen. Some extra features as pole pair, zero position or AGC programming can be achieved. The parameters will not be permanently programmed. All the parameters will be lost when the demoboard is shut down Hardware Indicators

3.1.1 Graphic LCD display

The LCD display shows the realtime absolute angle position of the magnet as a 8.5bit digital word (0...360). Turning the knob clockwise will increase the angle value until 359, then 0.

The Multiturn counter register will increment at each $359^\circ \rightarrow 0^\circ$ transition, and will decrease at each $0^\circ \rightarrow 359^\circ$ transition (counter clockwise). The Multiturn (MTURN) value is continuously read from the AS5132 Multiturn register.

The AGC value is continuously updated as well.

The magnet status indicator depends on the AGC value. If $AGC = 0$, the magnet is too close to the encoder. If $AGC = 31$, the magnet is too far away from the encoder (maximum AGC value).



Figure 2: LCD display in standalone mode (9V battery or USB powered without GUI)

3.1.2 PWM LED

This LED is connected to the PWM output of the AS5132. The PWM output is a pulse width that is proportional to the angle of the magnet.

The pulse width varies from $16\mu\text{s}$ to $734\mu\text{s}$ with a repetition rate of 1.33 kHz. Viewing the PWM signal on the LED results in a brightness that is proportional to the angle of the magnet. When the angle of the magnet is at 0° , the LED is almost dark, as it is $16\mu\text{s}$ on and $734\mu\text{s}$ off. Turning the knob clockwise towards higher angles increases the brightness of the PWM LED, since the ON-pulse becomes longer and the OFF-pulse becomes shorter.

Likewise, the PWM output can be used as an analog output proportional to the angle, when the PWM signal is filtered by a RC (or active) lowpass filter.

The PWM signal (0-5V) can be directly taken from the connector J4.

3.1.3 UVW commutation LED

The UVW commutation signals are used to control the electrical angle information of a BLDC motor (see AS5134 Datasheet Figure 10).

The UVW LEDs are directly connected to the U V W outputs of the AS5134. These UVW signals (0-5V) are available on connector J7.

4 AS5000 Programmer GUI software

4.1 Installing the GUI on the PC

The preliminary software is developed for a Microsoft Windows 7. For Microsoft Windows XP the dotnet (.NET) framework version 2.0 or more must be installed on the PC. This package can be downloaded free of charge from the Microsoft webpage:
<http://www.microsoft.com/downloads/details.aspx?FamilyID=0856eacb-4362-4b0d-8edd-aab15c5e04f5&displaylang=en>

Following Procedure is recommended before starting the GUI:

1. check on your PC if Service Pack 2 is installed (Only for
2. install the mentioned .NET package to your computer
3. execute setup.exe
4. Finally start the GUI using the shortcut in the start menu or desktop.

4.2 The Home tab

Figure 3 shows the main window of the GUI. On the top left corner, board informations as firmware (FW) version and demoboard name declaration can be found.

By default the GUI is in the auto detection mode. Any connected austriamicrosystems demoboard and programming tool will be automatically detected and displayed in the right top corner. The GUI is divided into three main sections HOME, TWI and OTP.

By selecting the TWI (AS5132 bidirectional serial protocol) tab, the information of the angular position and the status bits appears. See figure 4.



Figure 3: AS5000 GUI detected the AS5132 Demoboard

4.3 The TWI tab

This mode displays in realtime the angle value, Multiturn register value, AGC value and the UVW signal status.

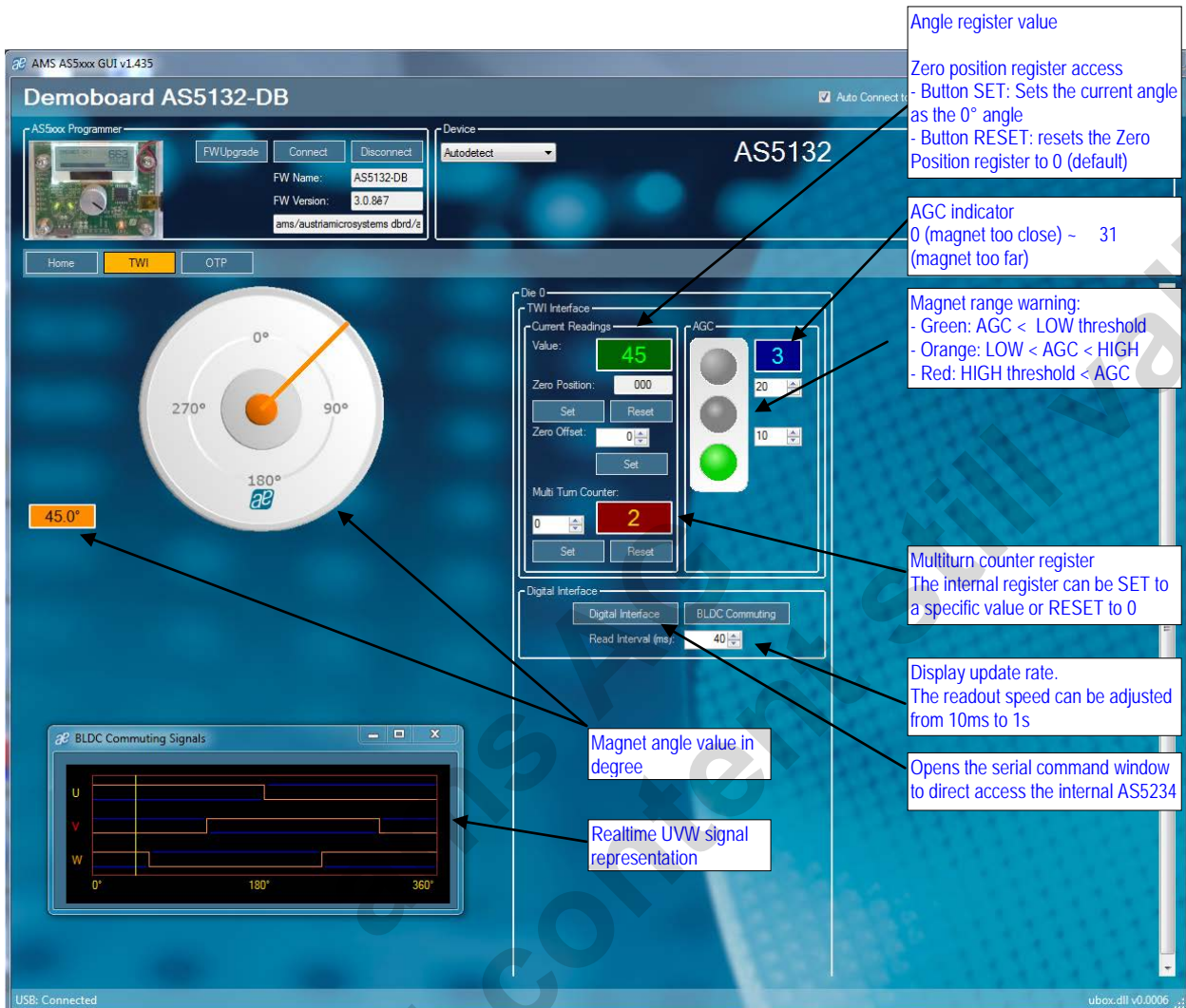

Figure 4: TWI tab, allows access to the AS5132 registers from the serial bus

Value is the Angle[8:0] from the RD_ANGLE (Read Angle) serial command. This value is continuously updated.

The **Zero Position** value represents the Zero Position register. By clicking on the **Set** button, the actual angle "Value" is written into the Zero Position register. Clicking on **Reset** writes the value 0 to the Zero Position register.

The **Multiturn Counter** field is the Multiturn-counter[8:0] register value from the READ_MT_COUNTER serial command. The Multiturn counter register can be set to a specific value by entering the turn number and clicking on **Set**. The counter can be reseted to 0 (default value) by clicking on **Reset**.

The **AGC** value is continuously read from the RD_ANGLE serial command.

The range lamp can be set by two thresholds (Green → Orange and Orange → Red) which are determined by the user. Those thresholds have no influence on the AS5132, it is a visual representation only.

The **Read Interval** can be modified from 10 ms (fastest) to 1 s (slowest).

The **BLDC Commuting Signals** sub-window is a realtime representation of the commutation signal status on the AS5132 UVW outputs. For changing the number of pole pairs, see chapter **Error! Reference source not found.**

By clicking on [Digital Interface](#), a new window opens, and allows the user to write directly into the AS5134 registers. See chapter 4.4.

ams AG
Technical content still valid

4.4 Digital Interface sub-window

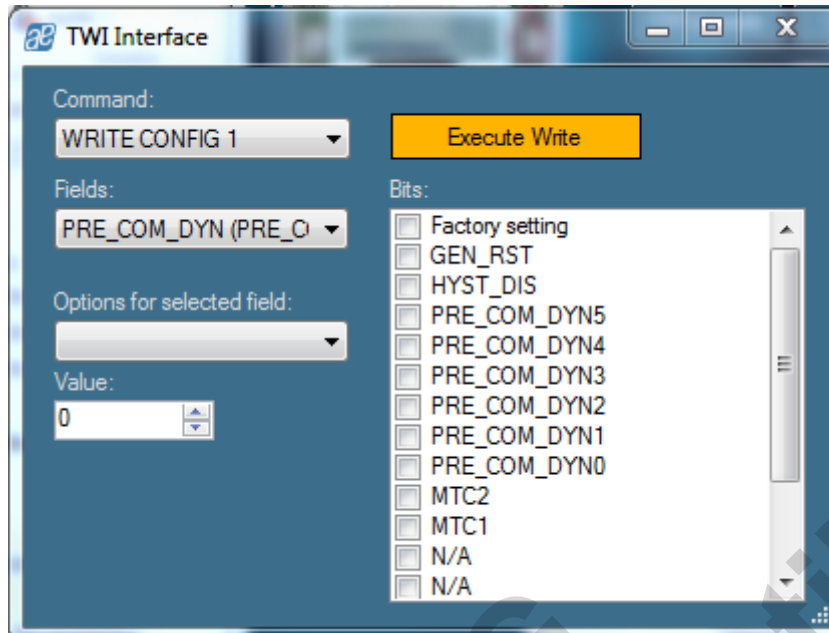

Figure 5: TWI interface sub-window

The Digital interface window allows accessing the internal registers of the AS5132:

Command Name	Command Data	Access Mode	MSB	15	14	13	12	11	10	9	8	7	6	5	4	3	2	1	0	LSB	
WRITE CONFIG	0001_0111	write			GEN RST	Hyst Dis	PRE_COM_DYN<5:0>					MTC2	MTC1								
SET MT COUNTER	0001_0100	write	MT - COUNTER <8:0>																		
EN PROG	1000_0100	write	0	1	1	0	0	1	0	1	0		1	1	1	0	0	0	0	0	
RD MT COUNTER	0000_0100	read	MT - COUNTER <8:0>																		
RD_ANGLE	0000_0000	read	ANGLE <8:0>										LOCK ADC	AGC <5:1>					P		

The parameters don't need to be checked manually in the "Bits" window on the right, but can be set by the "Fields" and "Options for the selected bits" values. The corresponding bits will be checked automatically.

PRE_COM_DYN: Absolute dynamic pre-commutation value. Depending on the setup of the pole pairs, a mechanical angle offset can be adjusted. The range is 0 to 63 mechanical degrees (LSBs)

To validate the command, the Execute Write button must be clicked.

4.5 OTP tab

The OTP tab is normally used for the AS5000 programmer, but the OTP bits can be changed on the AS5132 demoboard as well.

Options like sensitivity, incremental output mode, UVW output mode can be changed by selecting the function in "Fields", then changing the parameter in "Options for the selected field" or directly the decimal value of this parameter in "Value".

Each time a field's value has been changed, the corresponding OTP bits will be automatically checked in the right window. The button **Write** should be clicked to write the parameter into the AS5132.

The **Read** button reads back the OTP register, and updates the "Field" parameter as well as the OTP bits window.

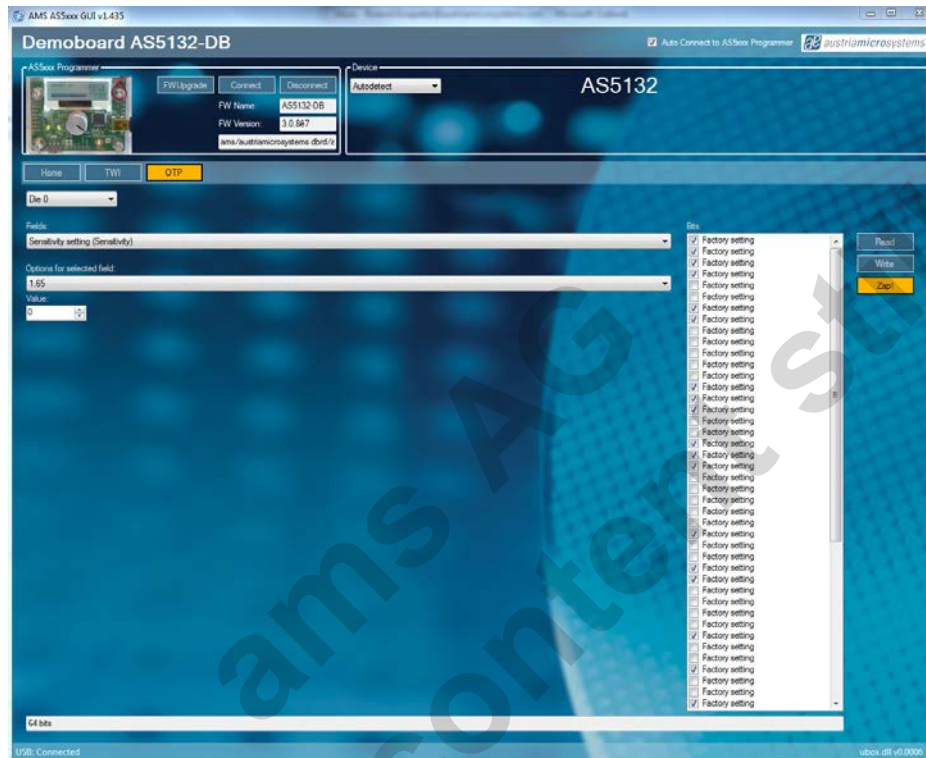

Figure 6: OTP tab

Field Sensitivity: Sets the gain of the internal signal path (typ).

- 0: Sensitivity = 1.65
- 1: Sensitivity = 1.88
- 2: Sensitivity = 2.11
- 3: Sensitivity = 2.35

PRE_COM_STAT: Set the static pre-commutation (mechanical Degrees)

- 0: 0°
- 1: 2°
- 2: 4°
- 3: 8°

Field UVW: To change the BLDC pole pairs. The result can be checked in realtime in the BLDC window. In the step mode configuration, the bit UVW<2> is used to invert the step mode output.

- 0: Sensitivity = 1 pole pair
- 1: Sensitivity = 2 pole pair
- 2: Sensitivity = 3 pole pair
- 3: Sensitivity = 4 pole pair
- 4: Sensitivity = 5 pole pair
- 5: Sensitivity = 6 pole pair
- 6: Sensitivity = 6 pole pair
- 7: Sensitivity = 6 pole pair

Field Zero Position: To zero position value, like on the TWI tab. The zero position value can be changed by checking the Z[0:8] bits, or changing the Value field with a decimal number.

Note that the **Zap!** button is used for the AS5000 Programmer only and has no effect on the AS5132 Demoboard.

ams AG
Technical content still valid

5 AS5132 Demoboard Schematics

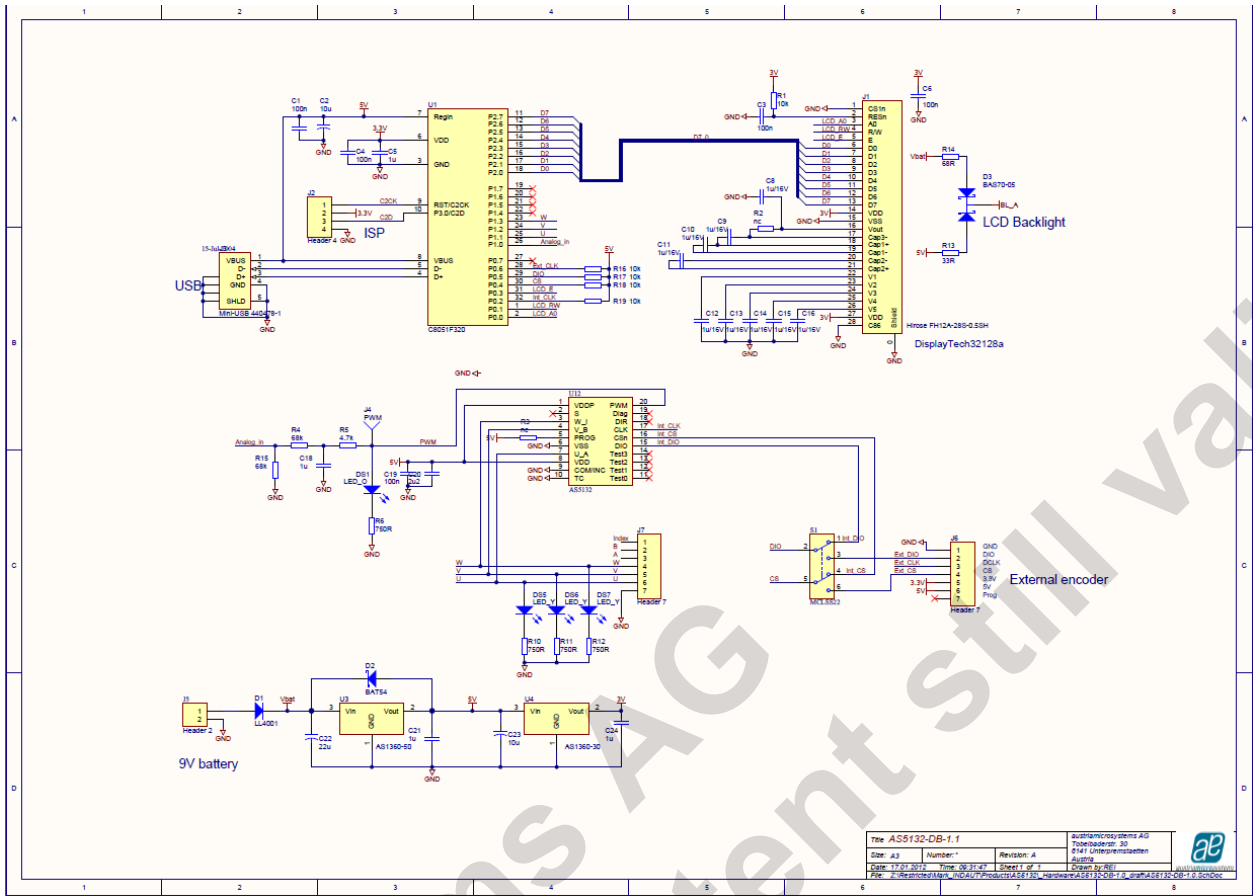

Figure 7: AS5132 Demoboard schematics

Index

1	General Overview	1
2	The AS5132 Demoboard	1
3	Operating the AS5132 Demoboard	2
3.1	Hardware Indicators	2
3.1.1	Graphic LCD display	2
3.1.2	PWM LED	2
3.1.3	UVW commutation LED	2
3.1.4	Incremental quadrature AB-Index LED	Error! Bookmark not defined.
4	AS5000 Programmer GUI software	3
4.1	Installing the GUI on the PC	3
4.2	The Home tab	3
4.3	The TWI tab	4
4.4	Digital Interface sub-window	6
4.5	OTP tab	7
5	AS5132 Demoboard Schematics	9
	Index	10
	Revision History	11
	Contact	12
	Copyright	13

Revision History

Revision	Date	Description
1.0	April 04, 2012	First version

ams AG
Technical content still valid

Contact

Headquarters

austriamicrosystems AG
 A 8141 Schloss Premstätten, **Austria**
 Phone: +43 3136 500 0
 Fax: +43 3136 525 01
industry.medical@austriamicrosystems.com
www.austriamicrosystems.com

Sales Offices

austriamicrosystems Germany GmbH
 Tegernseer Landstrasse 85
 D-81539 München, **Germany**
 Phone: +49 89 69 36 43 0
 Fax: +49 89 69 36 43 66

austriamicrosystems Italy S.r.l.
 Via A. Volta, 18
 I-20094 Corsico (MI), **Italy**
 Phone: +39 02 4586 4364
 Fax: +39 02 4585 773

austriamicrosystems France S.A.R.L.
 124, Avenue de Paris
 F-94300 Vincennes, **France**
 Phone: +33 1 43 74 00 90
 Fax: +33 1 43 74 20 98

austriamicrosystems Switzerland AG
 Rietstrasse 4
 CH 8640 Rapperswil, **Switzerland**
 Phone: +41 55 220 9008
 Fax: +41 55 220 9001

austriamicrosystems UK, Ltd.
 88, Barkham Ride,
 Finchampstead, Wokingham
 Berkshire RG40 4ET, **United Kingdom**
 Phone: +44 118 973 1797
 Fax: +44 118 973 5117

austriamicrosystems AG
 Klaavuntie 9 G 55
 FI 00910 Helsinki, **Finland**
 Phone: +358 9 72688 170
 Fax: +358 9 72688 171

austriamicrosystems AG
 Bivågen 3B
 S 19163 Sollentuna, **Sweden**
 Phone: +46 8 6231 710

austriamicrosystems USA, Inc.
 8601 Six Forks Road
 Suite 400
 Raleigh, NC 27615, **USA**
 Phone: +1 919 676 5292
 Fax: +1 509 696 2713

austriamicrosystems USA, Inc.
 4030 Moorpark Ave
 Suite 116
 San Jose, CA 95117, **USA**
 Phone: +1 408 345 1790
 Fax: +1 509 696 2713

austriamicrosystems AG
 Suite 811, Tsimshatsui Centre
 East Wing, 66 Mody Road
 Tsim Sha Tsui East, Kowloon, **Hong Kong**
 Phone: +852 2268 6899
 Fax: +852 2268 6799

austriamicrosystems AG
 AIOS Gotanda Annex 5th Fl., 1-7-11,
 Higashi-Gotanda, Shinagawa-ku
 Tokyo 141-0022, **Japan**
 Phone: +81 3 5792 4975
 Fax: +81 3 5792 4976

austriamicrosystems AG
 #805, Dong Kyung Bldg.,
 824-19, Yeok Sam Dong,
 Kang Nam Gu, Seoul
Korea 135-080
 Phone: +82 2 557 8776
 Fax: +82 2 569 9823

austriamicrosystems AG
 Singapore Representative Office
 83 Clemenceau Avenue, #02-01 UE Square
 239920, **Singapore**
 Phone: +65 68 30 83 05
 Fax: +65 62 34 31 20

Copyright

Devices sold by austriamicrosystems are covered by the warranty and patent indemnification provisions appearing in its Term of Sale. austriamicrosystems makes no warranty, express, statutory, implied, or by description regarding the information set forth herein or regarding the freedom of the described devices from patent infringement. austriamicrosystems reserves the right to change specifications and prices at any time and without notice. Therefore, prior to designing this product into a system, it is necessary to check with austriamicrosystems for current information. This product is intended for use in normal commercial applications.

Copyright © 2012 austriamicrosystems. Trademarks registered ®. All rights reserved. The material herein may not be reproduced, adapted, merged, translated, stored, or used without the prior written consent of the copyright owner. To the best of its knowledge, austriamicrosystems asserts that the information contained in this publication is accurate and correct. However, austriamicrosystems shall not be liable to recipient or any third party for any damages, including but not limited to personal injury, property damage, loss of profits, loss of use, interruption of business or indirect, special, incidental or consequential damages, of any kind, in connection with or arising out of the furnishing, performance or use of the technical data herein. No obligation or liability to recipient or any third party shall arise or flow out of austriamicrosystems rendering of technical or other services.