

Dimensions: mm (in.)

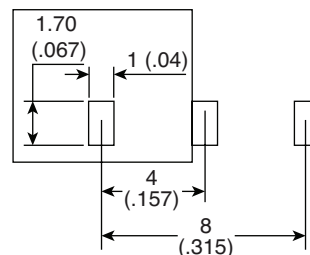

PCB Layout

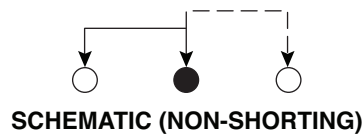
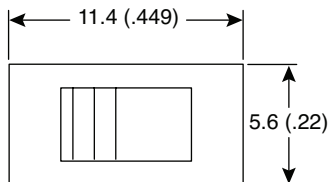
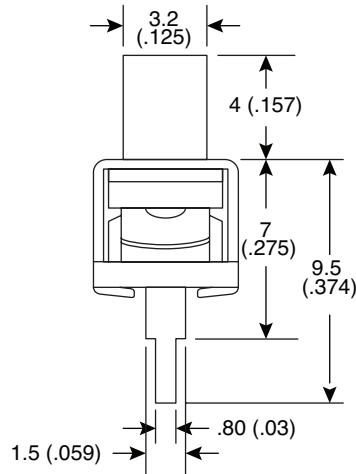
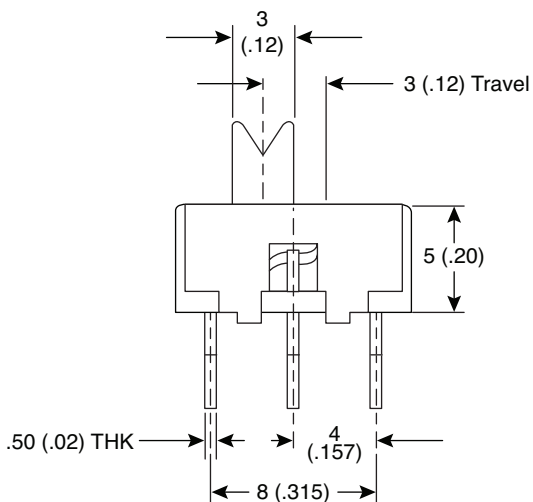

Electrical Specifications:

- Rating: 0.5A/50V DC
- Contact Resistance: 30m max.
- Insulation Resistance: 100M min.
- Dielectric Stragth: 500VAC 1 minute

Mechanical Specifications:

- Timing: Non-shorting
- Operating Force: 200gf ± 100gf
- Life test: 10,000 cycles, 15-18 cycles/min
- Type: SPDT

Note:

- RoHS Compliant

Slide Switch
103-1211P-EV

