

REVISIONS				
REV	ECO	DESCRIPTION	DATE	BY APPR
A1	-	RELEASED DRAWING	Jul-16-18	Flan Tommy

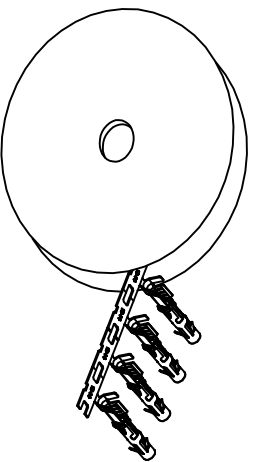

CONTACT ORIENTATION ON ROLL(3000PCS/COIL)

NOTES : (UNLESS OTHERWISE SPECIFIED)

1. MATERIAL :
 - 1.1. CONTACT BODY : COPPER ALLOY.
 - 1.2. OUTER SPRING : STAINLESS STEEL.
2. SPECIFICATIONS :
 - 2.1 CURRENT RATING : 13A MAX.
 - 2.2 TERMINATION TYPE : CRIMPING.
 - 2.3 WIRE RANGE : 14~16AWG.
 - 2.4 WIRE INSULATION DIA(MAX) : ϕ 3.2mm.
3. RoHS COMPLIANT.
4. ALL DIMENSIONS ARE FOR REFERENCE USE ONLY.
5. AVAILABLE TOOLS :
 - 5.1 HAND CRIMPER : MFX-3954.
 - 5.2 CRIMP APPLICATOR : MFX-3957.
 - 5.3 EXTRACTION TOOL : QXRT16.

P/N	CONTACT PLATING(MATING AREA)
SS14M2T	TIN PLATING OVER NICKEL.
SS14M2N	NICKEL PLATING OVER COPPERIZE.
SS14M2F	GOLD FLASH PLATING OVER NICKEL.
SS14M2G5	5 μ "GOLD PLATING OVER NICKEL.
SS14M2G10	10 μ "GOLD PLATING OVER NICKEL.
SS14M2G15	15 μ "GOLD PLATING OVER NICKEL.
SS14M2G30	30 μ "GOLD PLATING OVER NICKEL.

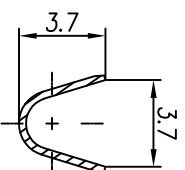

SECTION A-A

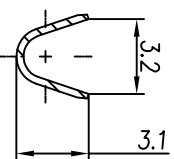

SECTION B-B

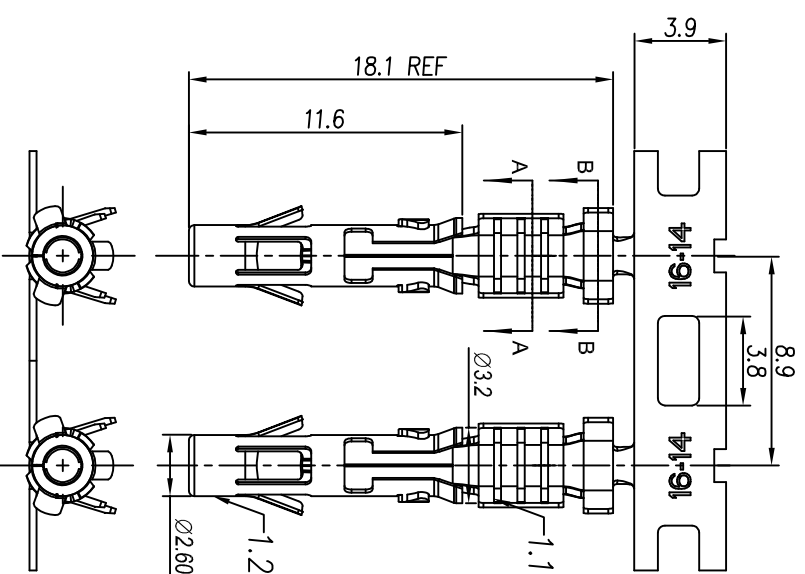

QUANTITY	PART NUMBER	DESCRIPTION	ITEM

MATERIALS LIST			
UNLESS OTHERWISE SPECIFIED 1) All dimensions are in millimeters. 2) Tolerances are as follows: 1 PL, DEC 240.30 Fractions, ±1/4 3 PL, DEC 240.08 Angles, ±1° 3) Note reference = Δ	SIGNATURES	DATE	
DRAWN: Flan	Jul-16-18		
CHECKED: Jod	Jul-16-18		
ENGINEER:			
APPROVAL: Tommy	Jul-16-18		
CUSTOMER:			

PROCESS SPECIFICATIONS			
FIRST DRAWING IS SUPERSEDES ALL PREVIOUS DRAWINGS. SPECIFICATIONS AND PERFORMANCE DATA ARE SUBJECT TO CHANGE WITHOUT NOTICE. THE MANUFACTURING CORPORATION NO RIGHTS OF REPRODUCTION ARE GRANTED. ALL MANUFACTURING VARIATIONS.			
SCALE: NONE	SIZE: B	TYPE: C-	DWG NO: SS14M2XX
SHEET: 1	OF: 1	REVISION: A1	

Amphenol

Sine Systems - www.amphenol-sine.com
44724 Morley Drive
Clinton Township, MI 48036

ECO-MATE SOCKET CONTACT,
STAMPED, 14-16AWG, SIZE 16