

**SF2425E**

**868.6 MHz  
SAW Filter**

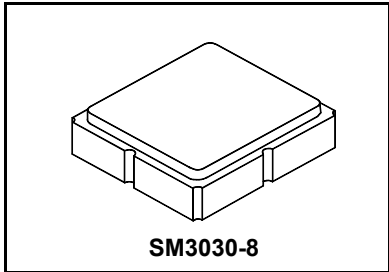

- 868.6 MHz Low-loss SAW Filter
- Surface Mount 3.0 x 3.0 mm Package
- Complies with Directive 2002/95/EC (RoHS)



**Absolute Maximum Ratings**

Rating	Value	Units
Input Power Level	15	dBm
DC Voltage on any Non-ground Terminal	5	V
Operable Temperature Range	-45 to +125	°C
Specification Temperature Range	-40 to +85	°C
Storage Temperature Range in Tape and Reel	-40 to +85	°C
Solder Reflow Temperature, 10 seconds, 5 cycles maximum	260	°C

**Electrical Characteristics**

Characteristic	Sym	Notes	Min	Typ	Max	Units
Center Frequency	$f_C$			868.6		MHz
Minimum Insertion Loss, incl. loss of matching elements	$IL_{MIN}$	1		2.65	3.50	dB
3dB BW			1.3	1.5		MHz
Attenuation (Relative to $IL_{min}$ )		1				dB
10.00 to 820.00 MHz			40	45		
820.00 to 859.00 MHz			28	33		
859.00 to 866.60 MHz			18	23		
866.60 to 867.20 MHz			10	14		
870.40 to 871.40 MHz			10	20		
871.40 to 875.00 MHz			15	19		
875.00 to 890.00 MHz			14	17		
890.00 to 950.00 MHz			32	36		
950.00 to 1500.00 MHz			50	55		
1500.00 to 2420.00 MHz			48	65		
2420.00 to 2500.00 MHz			-35	-40		
Case Style	SM3030-8 3.0 x 3.0 mm Nominal Footprint					
Lid Symbolization, Y=year, WW=week, S=shift, dot=pin 1 indicator	8J, YWWS					
INPUT $Z_{in} = R_{in}    C_{in}$				386  1.6		$\Omega    pF$
OUTPUT $Z_{out} = R_{out}    C_{out}$				371  1.8		



**CAUTION: Electrostatic Sensitive Device. Observe precautions for handling.**

**NOTES:**

1. The matching circuit is real by actual passive components.  
0805 Coilcraft CS series chip is used for inductor.  
0402 MuRata GRM series is used for capacitor.
2. Murata, stylized Murata logo, and Murata N.A., Inc. are registered trademarks of Murata Manufacturing Co., Ltd.

# Frequency Characteristics

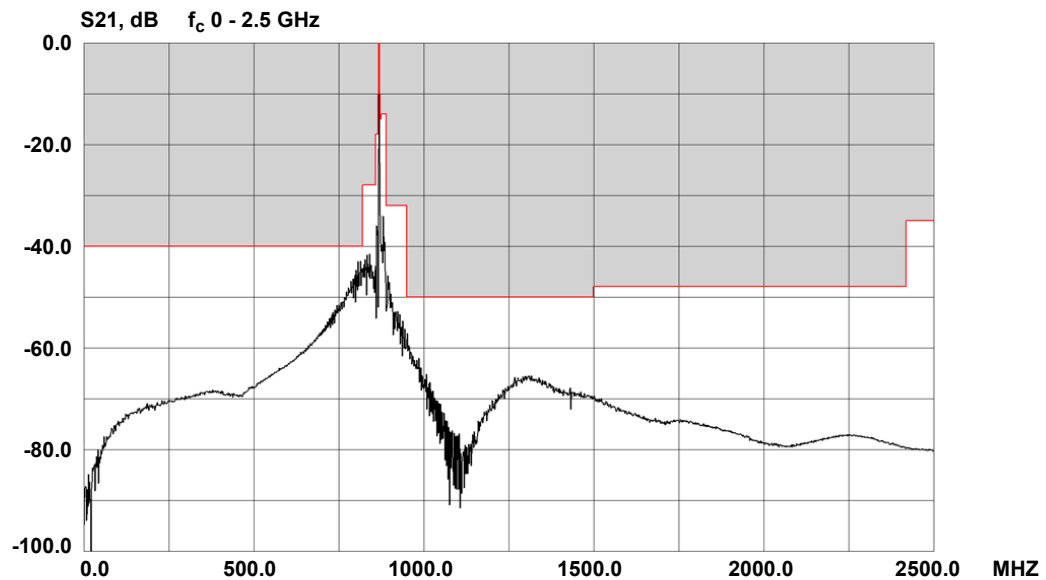
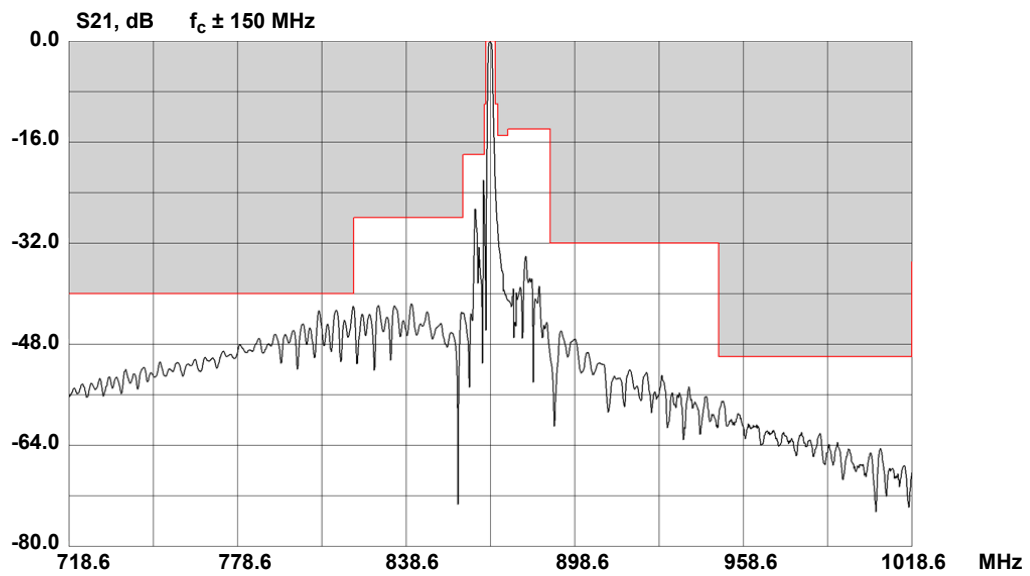
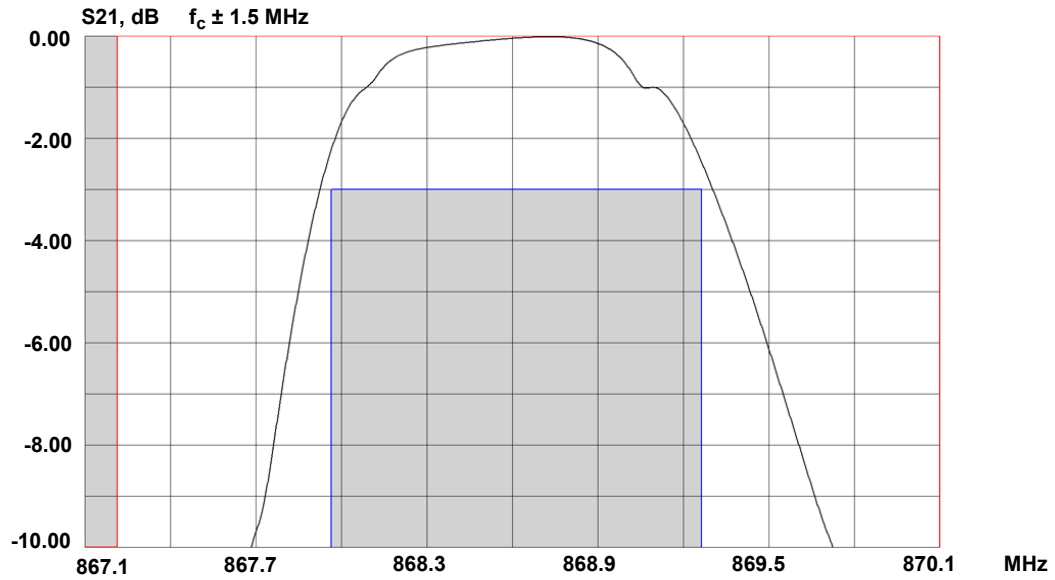

# SM3030-8 Case

## 8-Terminal Ceramic Surface-Mount Case 3.0 X 3.0 mm Nominal Footprint

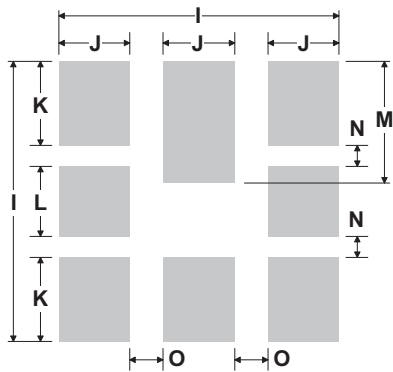
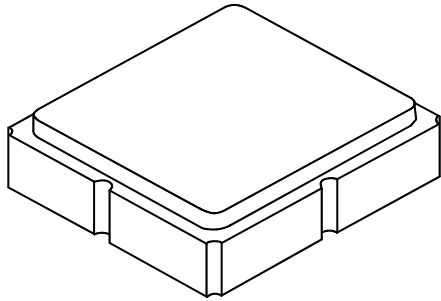

PCB Land Pattern  
Top View

### Electrical Connections

Connection	Terminals
Input Ground or Input	1
Input or Input Ground	2
Output Ground or Output	5
Output or Output Ground	6
Ground	3, 4, 7, 8

TOP VIEW

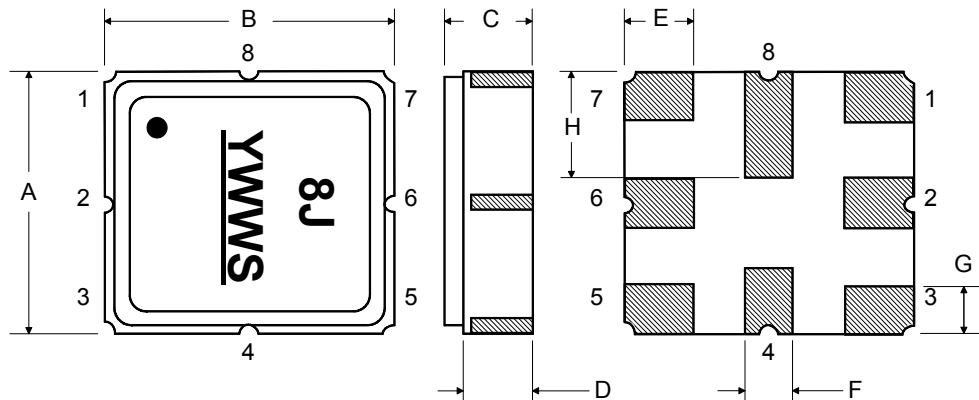

BOTTOM VIEW

### Case and PCB Footprint Dimensions

Dimension	mm			Inches		
	Min	Nom	Max	Min	Nom	Max
A	2.87	3.00	3.13	0.113	0.118	0.123
B	2.87	3.00	3.13	0.113	0.118	0.123
C	-	-	1.10	-	-	0.043
D	0.79	0.92	1.05	0.031	0.036	0.041
E	0.62	0.75	0.88	0.024	0.029	0.034
F	0.47	0.60	0.73	0.018	0.024	0.029
G	0.47	0.60	0.73	0.018	0.024	0.029
H	1.07	1.20	1.33	0.042	0.047	0.052
I		3.19			0.126	
J		0.81			0.032	
K		0.96			0.038	
L		0.81			0.032	
M		1.39			0.055	
N		0.23			0.009	
O		0.38			0.015	

### Case Materials

Materials	
Solder Pad Plating	0.3 to 1.0 $\mu\text{m}$ Gold over 1.27 to 8.89 $\mu\text{m}$ Nickel
Lid Plating	2.0 to 3.0 $\mu\text{m}$ Nickel
Body	$\text{Al}_2\text{O}_3$ Ceramic
Pb Free	

### Test Circuit

