

PART NUMBER	SSN-LX13049L-CD	REV.	D
DATE	E.C.N. NUMBER AND REVISION COMMENTS		REV.
07.19.95	REDRAWN.		A
03.02.99	E.C.N. #10BRDR. & REDRAWN (MODELED).		B
11.16.06	E.C.N. #11148.		C
09.14.11	E.C.N. #10BRDR. & REDRAWN.		D

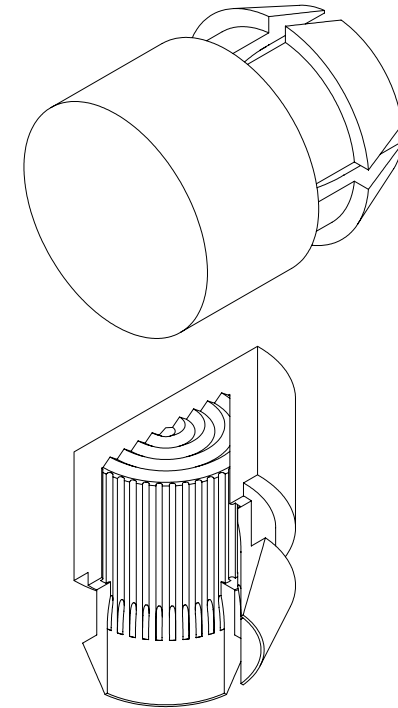
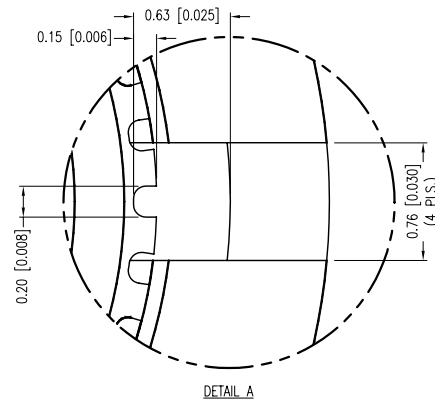
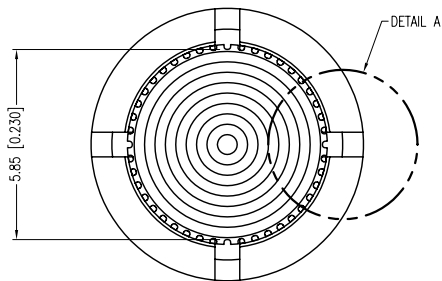
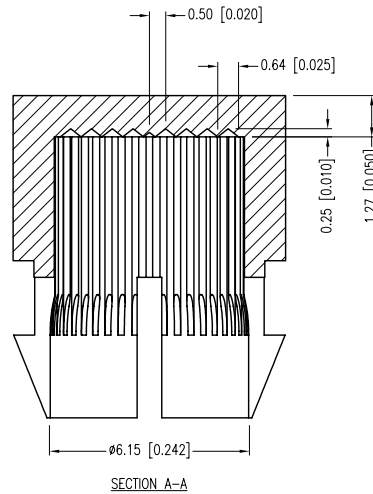
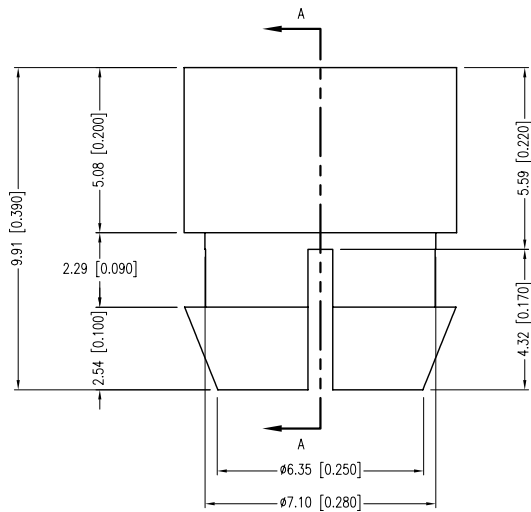
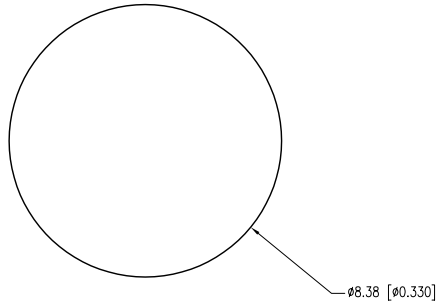

NOTES:

1. MATERIAL: POLYCARBONATE LEXAN 123 OR SIMILAR.
2. COLOR: CLEAR TRANSPARENT.
3. FINISH: OUTSIDE POLISHED, INSIDE AS MOLDED.
4. MOUNTING HOLE: 7.37 [0.290"] TO 7.95 [0.313"].

*UNLESS OTHERWISE SPECIFIED TOLERANCES PER DECIMAL PRECISION ARE: X=±1 (±0.039), X.X=±0.5 (±0.020), X.XX=±0.25 (±0.010), X.XXX=±0.127 (±0.005). LEAD SIZE=±0.05 (±0.002), LEAD LENGTH=±0.75 (±0.030). MIN.= +^{DECIMAL PRECISION} -0.00, MAX.= +0.00 -^{DECIMAL PRECISION}



290 E. HELEN ROAD
PALATINE, IL 60067-6976
PHONE: +1.847.359.2790
FAX: +1.847.359.6538
WEB: WWW.LUMEX.COM

LED PANEL LENS CLIP IN CLEAR POLYCARBONATE.

THE SPECIFICATIONS MAY CHANGE AT ANY TIME WITHOUT NOTICE DUE TO NEW MATERIALS OR PRODUCT IMPROVEMENT.

CONFIDENTIAL INFORMATION
THE INFORMATION CONTAINED IN THIS DOCUMENT IS THE PROPERTY OF LUMEX INC. EXCEPT AS SPECIFICALLY AUTHORIZED IN WRITING BY LUMEX INC., THE HOLDER OF THIS DOCUMENT SHALL KEEP ALL INFORMATION CONTAINED HEREIN CONFIDENTIAL AND SHALL PROTECT SAME IN WHOLE OR IN PART FROM DISCLOSURE AND DISSEMINATION TO ALL THIRD PARTIES.

DATE:	09.14.11	DRAWN BY:	AB
PAGE:	1 OF 1	CHKD BY:	KF
SCALE:	NTS	APRVD BY:	SS
UNIT:	mm [INCH]		Ⓟ