



Features

- Hybrid protection technology
- Extremely low leakage current
- EMI/RFI noise filtering
- Heavy duty surge protection with filtering
- LED indicators and audible alarm
- Compact form factor
- Indoor or outdoor installation
- UL1449 4th Edition
- RoHS compliant*

1252 Series Hardwired AC Hybrid Surge Protective Device (H-SPD)

General Information

The Bourns® Model 1252 Series is a Type 2 hardwired hybrid surge protective device targeted for AC infrastructure applications. The hybrid Model 1252 design combines fast responding MOV technology with low leakage GDT technology resulting in reliable and long term performance. The Model 1252 Series also includes filtering circuitry for additional noise mitigation.

Electrical Characteristics

Characteristic		Model No.		
		1252-120S	1252-208Y	1252-240S
Electrical Distribution System		120 VAC Single Ph	120 / 208 VAC 3 Ph Wye	120 / 240 VAC Single Ph
Nominal (Operating) Voltage		120 VAC	120 / 208 VAC	120 / 240 VAC
Maximum Operating Voltage	MCOV	150 VAC		
Temporary Overvoltage Withstand	U_T	150 VAC		
Nominal Discharge Current in 15 Applications of 8/20 μ s Impulse Waveform	I_n	20 kA		
Maximum Discharge Current 8/20 μ s Withstand Single Operation	I_{max}	50 kA		
Overvoltage Protection Rating (3 kA)	V_{pr}	700 VAC		
Protection Level at I_n	U_p-I_n	1200 VAC		
Short Circuit Current Rating	I_{scrr}	100 kA		

Disconnection Features / Options

Thermal Disconnect..... Internal
 Fuses or Circuit Breakers 40 A
 Ground Fault Breaker (if Installed) Type S or Delay

Mechanical Characteristics

Enclosure..... Aluminum
 Environmental Rating IP 66 / NEMA 4x
 Operating Temperature..... -40 °C to +85 °C
 Mounting..... Bulkhead (3/4)
 Weight 2.5 lbs.
 Disconnection Indicator LED off and audible alarm on
 Electrical Connection..... 12 AWG wiring leads, 20 inches max. length
 Mechanical Connection to Panel..... 12 gauge, straight nipple with conduit nut for mounting through 0.5 inch knockout (actual hole size 0.875 inch)

Standards Compliance

UL1449 4th Edition, Type 2 E313168
 CEI 61643-1, International..... Low Voltage SPD - Test Class II
 EN 61643-11, Europe Low Voltage SPD - Test Class II

How To Order

1252 - xxxx - xx

Series _____
 Nominal (Operating) Voltage _____
 120S = 120 VAC
 208Y = 120/208 VAC
 240S = 120/240 VAC
 Configuration _____
 N1= Wiring/Nipple Right Side Exit
 N2 =Wiring/Nipple Rear Exit

Packaging Specifications

1252 Series one unit per box

*RoHS Directive 2002/95/EC Jan. 27, 2003 including annex and RoHS Recast 2011/65/EU June 8, 2011. Specifications are subject to change without notice.

The device characteristics and parameters in this data sheet can and do vary in different applications and actual device performance may vary over time. Users should verify actual device performance in their specific applications.

Applications

- Service entrance, branch and OEM panels
- Electrical infrastructures
- Equipment and systems
- Protection from lightning
- Protection from AC power-induced problems

1252 Series Hardwired AC Hybrid Surge Protective Device (H-SPD) **BOURNS®**

Product Dimensions

N1 Configuration

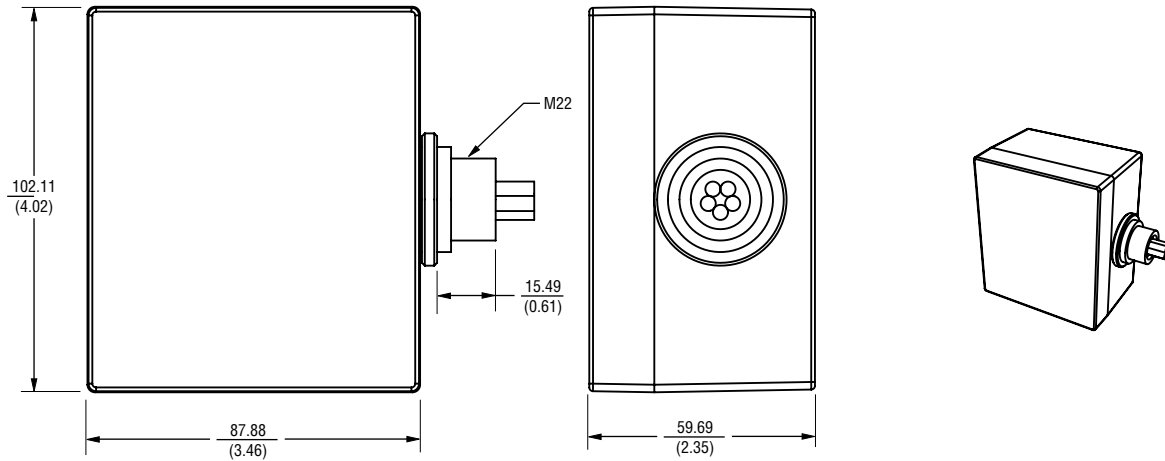

N2 Configuration

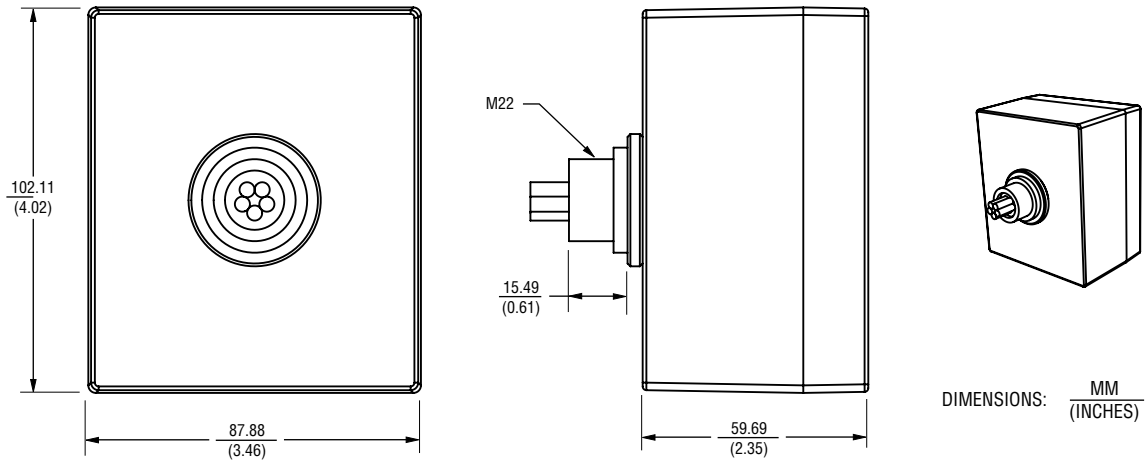

BOURNS®

Asia-Pacific: Tel: +886-2 2562-4117 • Email: asiacus@bourns.com

EMEA: Tel: +36 88 520 390 • Email: eurocus@bourns.com

The Americas: Tel: +1-951 781-5500 • Email: americus@bourns.com

www.bourns.com

REV. 07/16

Specifications are subject to change without notice.
The device characteristics and parameters in this data sheet can and do vary in different applications and actual device performance may vary over time.
Users should verify actual device performance in their specific applications.