

Features and Benefits

- Absolute Rotary Position Sensor IC
- Simple & Robust Magnetic Design
- Triaxis® Hall Technology
- Programmable Angular Range up to 360 Degrees
- Programmable Linear Transfer Characteristic (up to 16 points)
- Selectable SENT (SAE-J2716) Protocol, Analog (Ratiometric), PWM
- 12 bit Angular Resolution - 10 bit Angular Thermal Accuracy
- 48 bit ID Number
- Single Die – SO8 Package RoHS Compliant
- Dual Die (Full Redundant) – TSSOP16 Package RoHS Compliant



Applications

- Absolute Rotary Position Sensor
- EMS Actuator (EGR, Manifold...)
- Throttle Position Sensor
- Non-Contacting Potentiometer

Ordering Code

| Product Code | Temperature Code | Package Code | Option Code | Packing Form Code |
|--------------|------------------|--------------|-------------|-------------------|
| MLX90324 | L | DC | DBO-000 | TU |
| MLX90324 | L | DC | DBO-000 | RE |
| MLX90324 | L | GO | DBO-000 | TU |
| MLX90324 | L | GO | DBO-000 | RE |

Legend:

Temperature Code: L for Temperature Range -40°C to 150°C
 Package Code: DC for SOIC-8, GO for TSSOP-16
 Option Code: xxx-000: Standard version
 Packing Form: RE for Reel
 TU for Tube

Ordering example: MLX90324LDC-DBO-000-RE

1. Functional Diagram



Figure 1 - Block Diagram (Analog, PWM & SENT)

2. Description

The MLX90324 is a monolithic sensor IC featuring the Triaxis® Hall technology. Conventional planar Hall technology is only sensitive to the flux density applied orthogonally to the IC surface. The Triaxis® Hall sensor is also sensitive to the flux density applied parallel to the IC surface. This is obtained through an Integrated Magneto-Concentrator (IMC®) which is deposited on the CMOS die (as an additional back-end step).

The MLX90324 is only sensitive to the flux density coplanar with the IC surface. This allows the MLX90324 with the correct magnetic circuit to decode the absolute rotary (angular) position from 0 to 360 Degrees. It enables the design of novel generation of non-contacting rotary position sensors that are frequently required for both automotive and industrial applications.

In combination with the appropriate signal processing, the magnetic flux density of a small magnet (diametral magnetization) rotating above the IC can be measured in a non-contacting way (Figure 2). The angular information is computed from both vectorial components of the flux density (i.e. B_x and B_y). MLX90324 produces an output signal proportional to the decoded angle. The output is selectable between Analog, PWM and SENT (SAE-J2716) Protocol.



Figure 2 - Typical application of MLX90324

The MLX90324 is similar to the MLX90316 in many ways but it is targeted for “Under-the-Hood” applications and the associated harsh hi-temperature environment. Amongst others, the hi-temperature performances and the SENT feature confirm this devotion.

TABLE of CONTENTS

| | |
|---|-----------|
| FEATURES AND BENEFITS | 1 |
| APPLICATIONS..... | 1 |
| 1. FUNCTIONAL DIAGRAM..... | 2 |
| 2. DESCRIPTION..... | 2 |
| 3. GLOSSARY OF TERMS – ABBREVIATIONS – ACRONYMS | 5 |
| 4. PINOUT | 5 |
| 5. ABSOLUTE MAXIMUM RATINGS | 6 |
| 6. DETAILED DESCRIPTION..... | 6 |
| 7. MLX90324 ELECTRICAL SPECIFICATION..... | 9 |
| 8. MLX90324 ISOLATION SPECIFICATION | 11 |
| 9. MLX90324 TIMING SPECIFICATION..... | 11 |
| 10. MLX90324 ACCURACY SPECIFICATION | 12 |
| 11. MLX90324 MAGNETIC SPECIFICATION | 13 |
| 12. MLX90324 CPU & MEMORY SPECIFICATION | 13 |
| 13. MLX90324 END-USER PROGRAMMABLE ITEMS..... | 14 |
| 14. DESCRIPTION OF END-USER PROGRAMMABLE ITEMS..... | 15 |
| 14.1. OUTPUT MODE..... | 15 |
| 14.1.1. <i>Analog Output Mode</i> | 15 |
| 14.1.2. <i>PWM Output Mode</i> | 15 |
| 14.1.3. <i>SENT Output Mode</i> | 16 |
| 14.1.4. <i>Switch Out</i> | 16 |
| 14.2. OUTPUT TRANSFER CHARACTERISTIC..... | 17 |
| 14.2.1. <i>CLOCKWISE</i> Parameter..... | 17 |
| 14.2.2. <i>Discontinuity Point (or Zero Degree Point)</i> | 18 |
| 14.2.3. <i>3-Point LNR Parameters</i> | 18 |
| 14.2.4. <i>16-Point LNR Parameters</i> | 19 |
| 14.2.5. <i>CLAMPING</i> Parameters | 19 |
| 14.2.6. <i>DEADZONE</i> Parameter..... | 19 |
| 14.3. IDENTIFICATION | 20 |
| 14.4. SENSOR FRONT-END | 20 |
| 14.4.1. <i>HIGHSPEED</i> Parameter..... | 20 |
| 14.4.2. <i>AGC and Virtual Gain</i> Parameters | 20 |
| 14.4.3. <i>GAINMIN and GAINMAX</i> Parameters | 21 |
| 14.5. FILTER | 21 |
| 14.5.1. <i>Hysteresis Filter</i> | 21 |
| 14.5.2. <i>FIR Filters</i> | 21 |
| 14.5.3. <i>IIR Filters</i> | 23 |
| 14.6. PROGRAMMABLE DIAGNOSTIC SETTINGS | 24 |
| 14.6.1. <i>RESONFAULT</i> Parameter | 24 |
| 14.6.2. <i>EEHAMHOLE</i> Parameter | 24 |
| 14.7. LOCK..... | 24 |
| 14.7.1. <i>MLXLOCK</i> Parameter | 24 |
| 14.7.2. <i>LOCK</i> Parameter | 24 |
| 15. MLX90324 SELF DIAGNOSTIC..... | 25 |

| | | |
|------------|---|-----------|
| 16. | SENT (SAE-J2716) PROTOCOL | 27 |
| 16.1. | INTRODUCTION | 27 |
| 16.2. | SENT PROTOCOL DEFINITION | 27 |
| 16.3. | SENT PROTOCOL IMPLEMENTATION | 30 |
| 16.4. | USE OF THE MLX90324 SENT FEATURE..... | 30 |
| 17. | RECOMMENDED APPLICATION DIAGRAMS..... | 31 |
| 17.1. | ANALOG OUTPUT WIRING WITH THE MLX90324 IN SOIC PACKAGE..... | 31 |
| 17.2. | ANALOG OUTPUT WIRING WITH THE MLX90324 IN TSSOP PACKAGE..... | 32 |
| 17.3. | PWM LOW SIDE OUTPUT WIRING | 32 |
| 17.4. | SENT OUTPUT WIRING WITH THE MLX90324 IN SOIC-8 PACKAGE..... | 33 |
| 17.5. | SENT OUTPUT WIRING WITH THE MLX90324 IN TSSOP-16 PACKAGE..... | 33 |
| 18. | STANDARD INFORMATION REGARDING MANUFACTURABILITY OF MELEXIS PRODUCTS | |
| | WITH DIFFERENT SOLDERING PROCESSES | 34 |
| 19. | ESD PRECAUTIONS..... | 34 |
| 20. | PACKAGE INFORMATION..... | 35 |
| 20.1. | SOIC8 - PACKAGE DIMENSIONS | 35 |
| 20.2. | SOIC8 - PINOUT AND MARKING | 35 |
| 20.3. | SOIC8 - IMC POSITIONNING..... | 35 |
| 20.4. | TSSOP16 - PACKAGE DIMENSIONS..... | 37 |
| 20.5. | TSSOP16 - PINOUT AND MARKING | 38 |
| 20.6. | TSSOP16 - IMC POSITIONNING..... | 39 |
| 21. | DISCLAIMER..... | 41 |

3. Glossary of Terms – Abbreviations – Acronyms

- Gauss (G), Tesla (T): Units for the magnetic flux density – 1 mT = 10 G
- TC: **T**emperature **C**oefficient (in ppm/Deg.C.)
- NC: **N**ot **C**onnected
- PWM: **P**ulse **W**idth **M**odulation
- SENT: **S**ingle **E**dge **N**ibble **T**ransmission (Protocol – SAE-J2716)
- Nibble: 4 bits
- Byte: 8 bits (= 2 nibbles)
- Word: 16 bits (= 2 bytes = 4 nibbles)
- %DC: **D**uty **C**ycle of the output signal i.e. $T_{ON} / (T_{ON} + T_{OFF})$
- ADC: **A**nalog-to-**D**igital **C**onverter
- DAC: **D**igital-to-**A**nalog **C**onverter
- LSB: **L**east **S**ignificant **B**it
- MSB: **M**ost **S**ignificant **B**it
- DNL: **D**ifferential **N**on-**L**inearity
- INL: **I**ntegral **N**on-**L**inearity
- ASP: **A**nalog **S**ignal **P**rocessing
- DSP: **D**igital **S**ignal **P**rocessing
- ATAN: trigonometric function: arctangent (or inverse tangent)
- IMC: **I**ntegrated **M**agneto-**C**oncentrator (IMC®)

4. Pinout

| Pin # | SOIC-8 | TSSOP-16 |
|-------|---------------------|---|
| | Analog / PWM / SENT | Analog / PWM / SENT |
| 1 | VDD | VDIG ₁ |
| 2 | Test 0 | VSS ₁ (Ground ₁) |
| 3 | Switch Out | VDD ₁ |
| 4 | Not Used | Test 0 ₁ |
| 5 | Out | Switch Out ₂ |
| 6 | Test 1 | Not Used ₂ |
| 7 | VDIG | Out ₂ |
| 8 | VSS (Ground) | Test 1 ₂ |
| 9 | | VDIG ₂ |
| 10 | | VSS ₂ (Ground ₂) |
| 11 | | VDD ₂ |
| 12 | | Test 0 ₂ |
| 13 | | Switch Out ₁ |
| 14 | | Not Used ₁ |
| 15 | | Out ₁ |
| 16 | | Test 1 ₁ |

For optimal EMC behavior, it is recommended to connect the unused pins (Not Used and Test) to the Ground (see section 16.1).

5. Absolute Maximum Ratings

| Parameter | Value |
|---|--|
| Supply Voltage, VDD (overvoltage) | + 20 V |
| Reverse Voltage Protection | - 10 V |
| Positive Output Voltage | + 10 V + 14 V (200 s max - T _A = + 25°C) |
| Positive Output Voltage (Switch Out) | + 10 V + 14 V (200 s max - T _A = + 25°C) |
| Output Current (I _{OUT}) | ± 30 mA |
| Reverse Output Voltage | - 0.3 V |
| Reverse Output Current | - 50 mA |
| Operating Ambient Temperature Range, T _A | - 40°C ... + 150°C |
| Storage Temperature Range, T _S | - 40°C ... + 150°C |
| Magnetic Flux Density | ± 700 mT |

Exceeding the absolute maximum ratings may cause permanent damage. Exposure to absolute-maximum-rated conditions for extended periods may affect device reliability.

6. Detailed Description

As described on the block diagram (Figure 1 and Figure 2), the magnetic flux density parallel to the IC surface is sensed through the Triaxis® sensor front-end. This front-end consists into two orthogonal pairs (for each of the two directions parallel with the IC surface i.e. X and Y) of conventional planar Hall plates (blue area on Figure 3) and an Integrated Magneto-Concentrator (IMC® yellow disk on Figure 3).



Figure 3 - Triaxis® sensor front-end (4 Hall plates + IMC® disk)

While a magnet (e.g. diametrically magnetized) rotates above the IC as described on Figure 2, the sensing stage provides two differential signals in quadrature (sine and cosine – Figure 4 and Figure 5)



Figure 4 – Magnetic Flux Density – $B_x \propto \cos(\alpha)$ & $B_y \propto \sin(\alpha)$



Figure 5 – Triaxis® sensor front-end – Output signals – $V_x \propto B_x \propto \cos(\alpha)$ & $V_y \propto B_y \propto \sin(\alpha)$

Those Hall signals are processed through a fully differential analog chain featuring the classic offset cancellation technique (Hall plate quadrature spinning and chopper-stabilized amplifier).

The conditioned analog signals are converted through an ADC (configurable – 14 or 15 bits) and provided to a DSP block for further processing. The DSP stage is based on a 16 bit RISC micro-controller whose primary function is the extraction of the angular position from the two raw signals (after so-called front-end compensation steps) through the following operation:

$$\alpha = ATAN\left(\frac{V_Y}{V_X}\right)$$

The DSP functionality is governed by the micro-code (firmware – F/W) of the micro-controller which is stored into the ROM (mask programmable). In addition to the “ATAN” function, the F/W controls the whole analog chain, the output transfer characteristic, the output protocol, the programming/calibration and also the self-diagnostic modes.

In the MLX90324, the “ATAN” function is computed via a look-up table (i.e. it is not obtained through a CoRDIC algorithm - **Coordinate Rotation Digital Computer** [i.e. iterative rectangular-to-polar transform]) Due to the fact that the “ATAN” operation is performed on the ratio “ V_Y/V_X ”, the angular information is intrinsically self-compensated vs. flux density variations (due to airgap change, thermal or ageing effects) affecting both signals. This feature allows therefore an improved thermal accuracy vs. rotary position sensor based on conventional linear Hall sensors.

In addition to the improved thermal accuracy, the realized rotary position sensor is capable of measuring a complete revolution (360 Degrees) and the linearity performances are excellent taking into account typical manufacturing tolerances (e.g. relative placement between the Hall IC and the magnet).

Once the angular information is computed (over 360 degrees), it is further conditioned (mapped) vs. the target transfer characteristic and it is provided at the output(s) as:

- an analog output level through a 12 bit DAC followed by a buffer
- a digital PWM signal with 12 bit depth (programmable frequency 100 Hz ... 1 kHz)
- a digital SENT Protocol Telegram

For instance, the analog output can be programmed for offset, gain and clamping to meet any rotary position sensor output transfer characteristic:

$$\begin{array}{ll} V_{out}(\alpha) = \text{ClampLo} & \text{for } \alpha \leq \alpha_{min} \\ V_{out}(\alpha) = V_{offset} + \text{Gain} \times \alpha & \text{for } \alpha_{min} \leq \alpha \leq \alpha_{max} \\ V_{out}(\alpha) = \text{ClampHi} & \text{for } \alpha \geq \alpha_{max} \end{array}$$

where V_{offset} , Gain, ClampLo and ClampHi are the main adjustable parameters for the end-user.

The linear part of the transfer curve can be adjusted through either a 2 point or a 3 point calibration depending on the linearity requirement.

A digital output is also available and used as a programmable angular switch.

The calibration parameters are stored in EEPROM featuring a Hamming Error Correction Coding (ECC).

The programming steps do not require any dedicated pins. The operation is done using the supply and output nodes of the IC. The programming of the MLX90324 is handled at both engineering lab and production line levels by the Melexis Programming Unit PTC-04 with the dedicated MLX90316/90324 daughterboard and software tools (DLL – User Interface).

7. MLX90324 Electrical Specification

DC Operating Parameters at VDD = 5V (unless otherwise specified) and for TA as specified by the Temperature suffix (L).

| Parameter | Symbol | Test Conditions | Min | Typ | Max | Units |
|---|----------|---|----------|------|------------------|-------|
| Nominal Supply Voltage | VDD | | 4.5 | 5 | 5.5 | V |
| Supply Current ⁽¹⁾ | Idd | Slow mode ⁽²⁾ | | 7 | 10 | mA |
| | | Medium mode ⁽²⁾ | | 10.5 | 13 | mA |
| | | Fast mode ⁽²⁾ | | 12.5 | 15 | mA |
| POR Level | VDD POR | Supply Under Voltage | 2 | 2.7 | 3 | V |
| Output Current | Iout | Analog Output mode | -8 | | 8 | mA |
| | | PWM, SENT Output mode | -20 | | 20 | mA |
| Output Short Circuit Current | Ishort | Vout = 0 V | | 12 | 15 | mA |
| | | Vout = 5 V | | 12 | 15 | mA |
| | | Vout = 14 V (TA = 25°C) | | 24 | 45 | mA |
| Output Load | RL | Pull-down to Ground | 1 | 10 | ∞ ⁽⁴⁾ | kΩ |
| | | Pull-up to 5V ⁽³⁾ | 1 | 10 | ∞ ⁽⁴⁾ | kΩ |
| Analog Saturation Output Level | Vsat_lo | Pull-up load RL ≥ 10 kΩ | | | 3 | %VDD |
| | Vsat_hi | Pull-down load RL ≥ 10 kΩ | 96 | | | %VDD |
| Digital Saturation Output Level | VsatD_lo | Pull-up Low Side RL ≥ 10 kΩ Push-Pull (IOUT = -20mV) | | | 1.5 | %VDD |
| | VsatD_hi | Push-Pull (IOUT = 20mV) | 97 | | | %VDD |
| Active Diagnostic Output Level | Diag_lo | Pull-down load RL ≥ 10 kΩ Pull-up load RL ≥ 10 kΩ | | | 1 1.5 | %VDD |
| | Diag_hi | Pull-down load RL ≥ 10 kΩ Pull-up load RL ≥ 10 kΩ | 97 98 | | | %VDD |
| Passive Diagnostic Output Level (Broken Track Diagnostic) ⁽⁵⁾ | BVSSPD | Broken VSS & Pull-down load RL ≤ 10 kΩ | | | 4 | %VDD |
| | BVSSPU | Broken VSS & Pull-up load RL ≥ 1kΩ | 99 | 100 | | %VDD |
| | BVDDPD | Broken VDD & Pull-down load RL ≥ 1kΩ | | 0 | 1 | %VDD |
| | BVDDPU | Broken VDD & Pull-up load RL ≤ 10kΩ to 5V | 96 | | | %VDD |
| <i>MLX 90324 Electrical Specification continues...</i> | | | | | | |
| <i>...MLX 90324 Electrical Specification</i> | | | | | | |

¹ For the dual version, the supply current is multiplied by 2

² See section 14.4.1 for details concerning Slow and Fast mode

³ Applicable for output in Analog, PWM and SENT (Open-Drain) modes

⁴ RL < ∞ for output in PWM mode

⁵ For detailed information, see also section 15

| | | | | | | |
|---------------------------|----------|-------------------------|------|--|------|---------------------|
| Clamped Output Level | Clamp_lo | Programmable | 0 | | 100 | %VDD ⁽⁶⁾ |
| | Clamp_hi | Programmable | 0 | | 100 | %VDD ⁽⁶⁾ |
| Switch Out ⁽⁷⁾ | Sw_lo | Pull-up Load 1.5k to 5V | 0.55 | | 1.1 | V |
| | Sw_hi | Pull-up Load 1.5k to 5V | 3.65 | | 4.35 | V |

As an illustration of the previous table, the MLX90324 fits the typical classification of the output span described on the Figure 6.

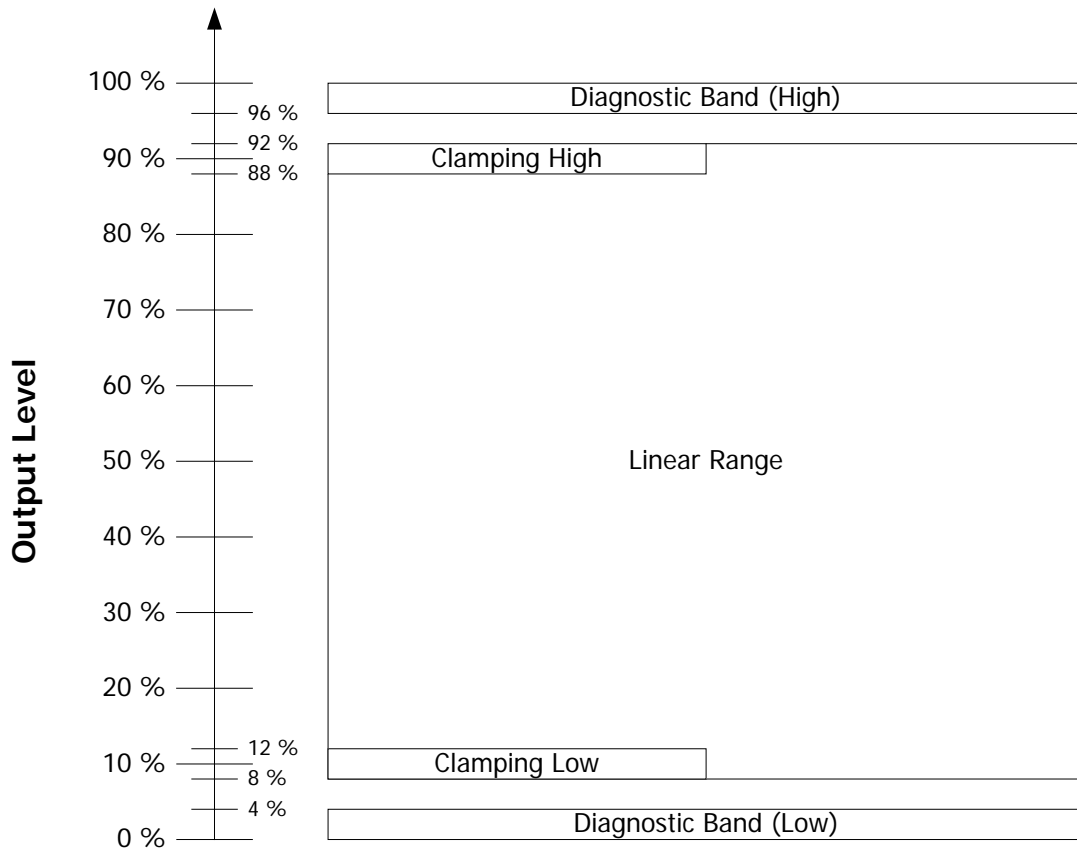

Figure 6 - Output Span Classification

⁶ Clamping levels need to be considered vs the saturation of the output stage (see Vsat_lo and Vsat_hi)

⁷ See section 14.1.4 for the application diagram

8. MLX90324 Isolation Specification

DC Operating Parameters at $V_{DD} = 5V$ (unless otherwise specified) and for T_A as specified by the Temperature suffix (L). Only valid for the package code GO i.e. dual die version.

| Parameter | Symbol | Test Conditions | Min | Typ | Max | Units |
|----------------------|--------|-----------------|-----|-----|-----|-------|
| Isolation Resistance | | Between 2 dies | 4 | | | MΩ |

9. MLX90324 Timing Specification

DC Operating Parameters at $V_{DD} = 5V$ (unless otherwise specified) and for T_A as specified by the Temperature suffix (L).

| Parameter | Symbol | Test Conditions | Min | Typ | Max | Units |
|--------------------------|------------------|--|-----|-----|------|-------|
| Main Clock Frequency | Ck | Slow mode ⁽⁸⁾ | | 5.5 | | MHz |
| | | Medium mode ⁽⁸⁾ | | 10 | | MHz |
| | | Fast mode ⁽⁸⁾ | | 16 | | MHz |
| Sampling Rate | | Slow mode ⁽⁸⁾ | | 600 | | μs |
| | | Medium mode ⁽⁸⁾ | | 400 | | μs |
| | | Fast mode ⁽⁸⁾ | | 330 | | μs |
| Step Response Time | Ts | Slow mode ⁽⁸⁾ , Filter=5 ⁽⁹⁾ | | | 4 | ms |
| | | Medium mode ⁽⁸⁾ , Filter=0 ⁽⁹⁾ | | | 1200 | μs |
| | | Fast mode ⁽⁸⁾ , Filter=0 ⁽⁹⁾ | 660 | | 1000 | μs |
| Watchdog | Wd | See Section 15 | | | 5 | ms |
| Start-up Cycle | Tsu | Slow, Medium and Fast mode ⁽⁸⁾ | | | 15 | ms |
| Analog Output Slew Rate | | $C_{OUT} = 40 - 100$ nF | | | | |
| | | Falling Edge | | 9 | | V/ms |
| | | Rising Edge | | 18 | | V/ms |
| PWM Frequency | F _{PWM} | PWM Output Enabled | 100 | | 1000 | Hz |
| Digital Output Rise Time | | Mode 5 – 10nF, R _L = 5.6 kΩ | | 120 | | μs |
| | | Mode 6 – 10nF, R _L = 5.6 kΩ | | 2.6 | | μs |
| | | Mode 7 – 10nF, R _L = 5.6 kΩ | | 2.6 | | μs |
| Digital Output Fall Time | | Mode 5 – 10nF, R _L = 5.6 kΩ | | 800 | | ns |
| | | Mode 6 – 10nF, R _L = 5.6 kΩ | | 120 | | μs |
| | | Mode 7 – 10nF, R _L = 5.6 kΩ | | 820 | | ns |

⁸ See section 14.4.1 for details concerning Slow, Medium and Fast mode

⁹ See section 14.5 for details concerning Filter parameter

10. MLX90324 Accuracy Specification

DC Operating Parameters at VDD = 5V (unless otherwise specified) and for T_A as specified by the Temperature suffix (L).

| Parameter | Symbol | Test Conditions | Min | Typ | Max | Units |
|--|------------------|---|------------|----------------|-------------|------------------------|
| ADC Resolution on the raw signals sine and cosine | R _{ADC} | Slow Mode ⁽¹⁰⁾ Medium Mode ⁽¹⁰⁾ Fast Mode ⁽¹⁰⁾ | | 15 14 14 | | bits bits bits |
| Thermal Offset Drift #1 ⁽¹¹⁾ | | Thermal Offset Drift at the DSP input (excl. DAC and output stage) | -60 | | +60 | LSB ₁₅ |
| Thermal Offset Drift #2 (to be considered only for the analog output mode) | | Thermal Offset Drift of the DAC and Output Stage | -0.4 | | +0.4 | %VDD |
| Thermal Drift of Sensitivity Mismatch ⁽¹²⁾ | | | -0.5 | | +0.5 | % |
| Intrinsic Linearity Error ⁽¹³⁾ | Le | T _A = 25°C | -1 | | 1 | Deg |
| Analog Output Resolution | R _{DAC} | 12 bits DAC (Theoretical – Noise free) INL DNL | -4 0.05 | 0.025 1 | +4 2 | %VDD/LSB LSB LSB |
| Output stage Noise | | Clamped Output | | 0.05 | | %VDD |
| Noise pk-pk ⁽¹⁴⁾ | | VG = 9, Slow mode, Filter=5 VG = 9, Fast mode, Filter=0 | | 0.03 0.1 | 0.06 0.2 | Deg Deg |
| Ratiometry Error | | | -0.1 | 0 | 0.1 | %VDD |
| PWM Output Resolution | R _{PWM} | 12 bits (Theoretical – Jitter free) | | 0.025 | | %DC/LSB |
| PWM Jitter ⁽¹⁵⁾ | J _{PWM} | VG = 6, F _{PWM} = 250 Hz – 800Hz | | | 0.2 | %DC |

¹⁰ 15 bits corresponds to 14 bits + sign and 14 bits corresponds to 13 bits + sign. After angular calculation, this corresponds to 0.005Deg/LSB₁₅ in Low Speed Mode and 0.01Deg/LSB₁₄ in High Speed.

¹¹ For instance, Thermal Offset Drift #1 equal ± 60LSB₁₅ yields to max. ± 0.3 Deg. angular error for the computed angular information (output of the DSP). See Front End Application Note for more details. This is only valid if automatic gain is set (See Section 14.4.2)

¹² For instance, Thermal Drift of Sensitivity Mismatch equal ± 0.4% yields to max. ± 0.1 Deg. angular error for the computed angular information (output of the DSP). See Front End Application Note for more details.

¹³ The Intrinsic Linearity Error refers to the IC itself (offset, sensitivity mismatch, orthogonality) taking into account an ideal rotating field. Once associated to a practical magnetic construction and the associated mechanical and magnetic tolerances, the output linearity error increases. However, it can be improved with the multi point end-user calibration that is available on the MLX90324.

¹⁴ The application diagram used is described in the recommended wiring. For detailed information, refer to section Filter in application mode (Section 14.5).

¹⁵ Jitter is defined by ± 3 σ for 1000 successive acquisitions and the slope of the transfer curve is 100%DC/360 Deg.

11. MLX90324 Magnetic Specification

DC Operating Parameters at $V_{DD} = 5V$ (unless otherwise specified) and for T_A as specified by the Temperature suffix (L).

| Parameter | Symbol | Test Conditions | Min | Typ | Max | Units |
|--------------------------------|--------|-----------------|-------|-----|--------------------|--------|
| Magnetic Flux Density | B | | 20 | 50 | 70 ⁽¹⁶⁾ | mT |
| Magnet Temperature Coefficient | TCm | | -2400 | | 0 | ppm/°C |

12. MLX90324 CPU & Memory Specification

The DSP is based on a 16 bit RISC μ Controller. This CPU provides 2.5 Mips while running at 10 MHz.

| Parameter | Symbol | Test Conditions | Min | Typ | Max | Units |
|-----------|--------|-----------------|-----|-----|-----|-------|
| ROM | | | | 10 | | kB |
| RAM | | | | 256 | | B |
| EEPROM | | | | 128 | | B |

¹⁶ Above 70 mT, the IMC starts saturating yielding to an increase of the linearity error.

13. MLX90324 End-User Programmable Items

| Parameter | Comments | Default Values | |
|-------------|--|--------------------|-------|
| | | - | # bit |
| Output Mode | Define the output stage mode | 2 | 3 |
| PWMPOL1 | PWM Polarity | 0 | 1 |
| PWM_Freq | PWM Frequency | 1000h | 16 |
| CLOCKWISE | | 0 | 1 |
| DP | Discontinuity Point | 0h | 15 |
| 16POINTS | Selection of correction method 3 or 16 pts | 0 | 1 |
| LNR_S0 | Initial Slope | 0h | 16 |
| LNR_A_X | AX Coordinate | 8000h | 16 |
| LNR_A_Y | AY Coordinate | 0h | 16 |
| LNR_A_S | AS Coordinate | 0h | 16 |
| LNR_B_X | BX Coordinate | FFFFh | 16 |
| LNR_B_Y | BY Coordinate | 0h | 16 |
| LNR_B_S | BS Coordinate | 0h | 16 |
| LNR_C_X | CX Coordinate | FFFFh | 16 |
| LNR_C_Y | CY Coordinate | FFFFh | 16 |
| LNR_C_S | CS Coordinate | 0h | 16 |
| LNR_Y0 | 16pts – Y-coordinate point 0 | N/A | 16 |
| LNR_Y1 | 16pts – Y-coordinate point 1 | N/A | 16 |
| ... | ... | ... | ... |
| LNR_Y16 | 16pts – Y-coordinate point 16 | N/A | 16 |
| CLAMP_HIGH | Clamping High | 8% | 16 |
| CLAMP_LOW | Clamping Low | 8% | 16 |
| KD | Switch Out | FFFFh | 16 |
| KDHYST | Hysteresis on the Switch Out | 0 | 8 |
| DEADZONE | | 0 | 8 |
| FHYST | | 4 | 8 |
| MELEXISID1 | | MLX | 16 |
| MELEXISID2 | | MLX | 16 |
| MELEXISID3 | | MLX | 16 |
| CUSTOMERID1 | | 1 | 8 |
| CUSTOMERID2 | | 17h | 16 |
| CUSTOMERID3 | | MLX | 16 |
| HIGHSPEED | | 0 | 1 |
| MEDIUMSPEED | | 0 | 1 |
| ROLLCNT | Rolling Counter (SENT) | 0 | 1 |
| FSWAP | | 0 | 1 |
| FILTER | | 5 | 8 |
| AGC | Automatic Gain Selection | 0 | 1 |
| GAINMIN | | 11 | 4 |
| GAINMAX | | 41 ⁽¹⁷⁾ | 4 |
| EEHAMHOLE | | 3131h | 16 |
| RESONFAULT | | 0 | 2 |
| SENT | | 0 | 1 |
| MLXLOCK | | 19h | 1 |
| LOCK | | 0 | 1 |

¹⁷ CodeGAINMAX programmed to value F0h (240d), clamped to maximum gain value 41d by FW

14. Description of End-User Programmable Items

14.1. Output Mode

The MLX90324 output type is defined by the Output Mode parameter.

| Parameter | Value | Description |
|--------------------|-------|---------------------|
| Analog Output Mode | 2 | Analog Rail-to-Rail |
| PWM Output Mode | 5 | Low Side (NMOS) |
| | 6 | High Side (PMOS) |
| | 7 | Push-Pull |
| SENT Output Mode | N/A | Push-Pull |

14.1.1. Analog Output Mode

The Analog Output Mode is a rail-to-rail and ratiometric output with a push-pull output stage configuration allows the use of a pull-up or pull-down resistor.

14.1.2. PWM Output Mode

If one of the PWM Output modes is selected, the output signal is a digital signal with Pulse Width Modulation (PWM).

In mode 5, the output stage is an open drain NMOS transistor (low side), to be used with a pull-up resistor to VDD.

In mode 6, the output stage is an open drain PMOS transistor (high side), to be used with a pull-down resistor.

In mode 7, the output stage is a push-pull stage.

The PWM polarity is selected by the PWMPOL1 parameter:

- PWMPOL1 = 0 for a low level at 100%
- PWMPOL1 = 1 for a high level at 100%

The PWM frequency is selected by the PWM_Freq parameter.

| PWM Frequency Code | | | | |
|--------------------|---------------------------------------|-------|-------|------|
| Oscillator Mode | Pulse-Width Modulation Frequency (Hz) | | | |
| | 100 | 200 | 500 | 1000 |
| Low Speed | 27500 | 13750 | 6875 | 3435 |
| Medium Speed | 50000 | 25000 | 10000 | 5000 |
| High Speed | - | 40000 | 16000 | 8000 |

For instance, in Low Speed Mode, set PWM_Freq = 6875 (decimal) to set the PWM frequency at 500Hz.

14.1.3. SENT Output Mode

The MLX90324 features a digital SENT (SAE-J2716) Protocol Mode. The rolling counter can be enabled/disabled by the ROLLCNT bit:

- ROLLCNT = 0 to enable the rolling counter
- ROLLCNT = 1 to disable the rolling counter

See the dedicated SENT Protocol section for a full description (Section 16).

14.1.4. Switch Out

| Parameter | Value | Unit |
|-----------|--------------|------|
| KD | 0...359.9999 | deg |
| KDHYST | 0 ... 1.4 | deg |

The switch is activated (Sw_lo) when the digital angle is greater than the value stored in the KD parameter. This angle refers to the internal angular reference linked to the parameter DP and not to the absolute physical 0° angle.

The KDHYST defines the hysteresis amplitude around the Switch point. The switch is actually activated if the digital angle is greater than $KD+KDHYST$. It is deactivated if the digital angle is less than $KD-KDHYST$.

The mandatory application diagram to use this feature is depicted in the Figure 7. See section 7 for the electrical characteristic.

If the Switch feature is not used in the application, the output pin needs to be connected to the ground.

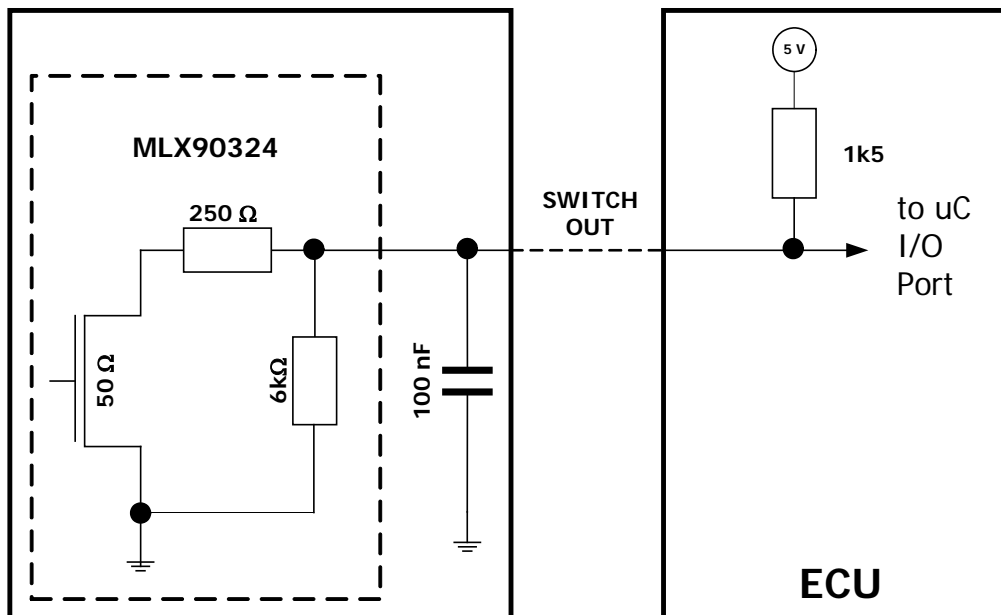

Figure 7 – Application Diagram for the Switch Out

14.2. Output Transfer Characteristic

There are 2 different possibilities to define the transfer function (LNR):

- With 3 points (defined on X and Y coordinates) and 4 slopes
- With 16 points equidistant where only Y coordinates are defined.

| Parameter | LNR type | Value | Unit |
|------------------------------------|-------------|-------------------|-------|
| CLOCKWISE | Both | 0 → CCW 1 → CW | |
| DP | Both | 0 ... 359.9999 | deg |
| LNR_A_X LNR_B_X LNR_C_X | Only 3 pts | 0 ... 359.9999 | deg |
| LNR_A_Y LNR_B_Y LNR_C_Y | Only 3 pts | 0 ... 100 | % |
| LNR_S0 | Only 3 pts | 0 ... 17 | %/deg |
| LNR_A_S LNR_B_S LNR_C_S | Only 3 pts | -17 ... 0 ... 17 | %/deg |
| LNR_Y0 LNR_Y1 ... LNR_Y16 | Only 16 pts | 0 ... 100 | % |
| CLAMP_LOW | Both | 0 ... 100 | % |
| CLAMP_HIGH | Both | 0 ... 100 | % |

14.2.1. CLOCKWISE Parameter

The CLOCKWISE parameter defines the magnet rotation direction.

- CCW is defined by the 1-4-5-8 pin order direction for the SOIC8 package and 1-8-9-16 pin order direction for the TSSOP16 package.
- CW is defined by the reverse direction: 8-5-4-1 pin order direction for the SOIC8 and 16-9-8-1 pin order direction for the TSSOP16 package.

Refer to the drawing in the IMC positioning sections (Section 20.3 and 20.6).

14.2.2. Discontinuity Point (or Zero Degree Point)

The Discontinuity Point defines the 0° point on the circle. The discontinuity point places the origin at any location of the trigonometric circle. The DP is used as reference for all the angular measurements.



Figure 8 - Discontinuity Point Positioning

14.2.3. 3-Point LNR Parameters

The LNR parameters, together with the clamping values, fully define the relation (the transfer function) between the digital angle and the output signal.

The shape of the MLX90324 transfer function from the digital angle value to the output voltage is described by the drawing below. Six segments can be programmed but the clamping levels are necessarily flat.

Two, three, or even five calibration points are then available, reducing the overall non-linearity of the IC by almost an order of magnitude each time. Three or five point calibration will be preferred by customers looking for excellent non-linearity figures. Two-point calibrations will be preferred by customers looking for a cheaper calibration set-up and shorter calibration time.



14.2.4. 16-Point LNR Parameters

The LNR parameters, together with the clamping values, fully define the relation (the transfer function) between the digital angle and the output signal. The shape of the MLX90324 transfer function from the digital angle value to the output voltage is described by the drawing below.

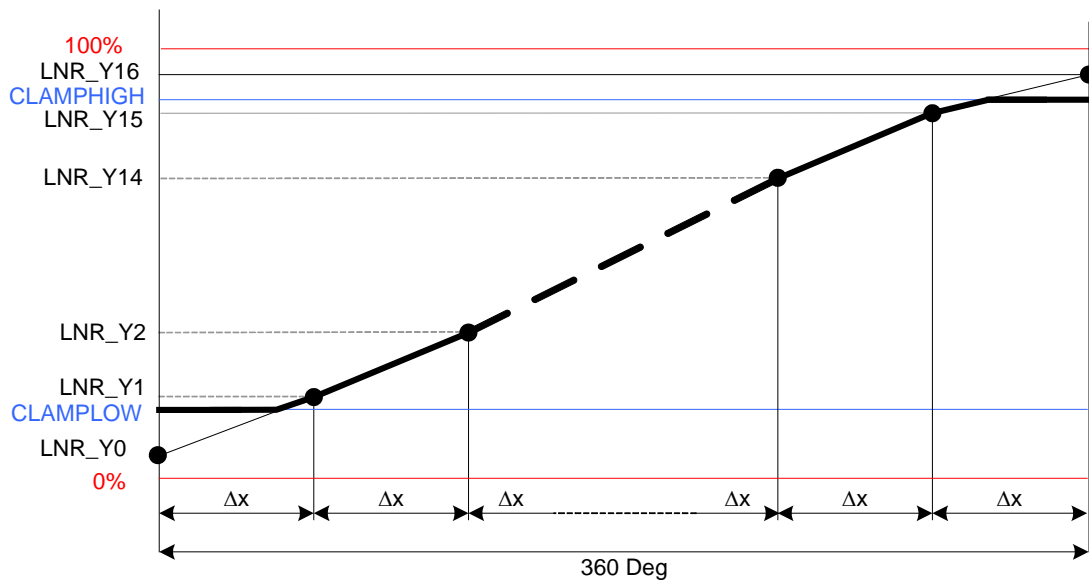

Figure 9 – 16-Point Calibration

14.2.5. CLAMPING Parameters

The clamping levels are two independent values to limit the output voltage range. The CLAMP_LOW parameter adjusts the minimum output voltage level. The CLAMP_HIGH parameter sets the maximum output voltage level. Both parameters have 16 bits of adjustment with a resolution of approximately 0.076 mV.

14.2.6. DEADZONE Parameter

The dead zone is defined as the angle window between 0 and 359.9999. When the digital angle lies in this zone, the IC is in fault mode (RESONFAULT must be set to “1” – See 14.6.1).

14.3. Identification

| Parameter | Value | Unit |
|-------------|-------------|------|
| MELEXSID1 | 0 ... 65535 | |
| MELEXSID2 | 0 ... 65535 | |
| MELEXSID3 | 0 ... 65535 | |
| CUSTOMERID1 | 0 ... 65535 | |
| CUSTOMERID2 | 0 ... 65535 | |
| CUSTOMERID3 | 0 ... 65535 | |

Identification number: 40 bits freely useable by Customer for traceability purpose.

14.4. Sensor Front-End

| Parameter | Value | Unit |
|-------------|----------------------------------|------|
| HIGHSPEED | 0 = Slow mode 1 = Fast mode | |
| MEDIUMSPEED | 0 = Slow mode 1 = Medium mode | |
| AGC | 0 = disable 1 = enable | |
| VirtualGain | 0 ... 41 | |
| GAINMIN | 0 ... 41 | |
| GAINMAX | 0 ... 41 | |

14.4.1. HIGHSPEED Parameter

The HIGHSPEED and MEDIUMSPEED parameters define the main frequency for the DSP.

- HIGHSPEED = 0, MEDIUMSPEED = 0 select the Slow mode with a 5.5 MHz master clock.
- HIGHSPEED = 0, MEDIUMSPEED = 1 select the Medium mode with a 10 MHz master clock.
- HIGHSPEED = 1, MEDIUMSPEED = 0 select the Fast mode with a 16 MHz master clock.

For better noise performance, the Slow Mode must be enabled.

14.4.2. AGC and Virtual Gain Parameters

The AGC parameter enables the automatic gain control of the analog chain. The AGC loop is based on $(V_x)^2 + (V_y)^2 = (\text{Amplitude})^2 = (\text{Radius})^2$

and it targets an amplitude of 90% of the ADC input span.

If AGC is “0”, the gain stored in the parameter GAINMIN is used.

Melexis strongly recommends to use AGC = 1.

Please note that the angular errors listed in the section 10 are only valid if the AGC is activated. AGC avoids also the saturation of the analog chain and the associated linearity error.

The current gain (VG) can be read out with the PTC-04 and gives a rough indication of the applied magnetic flux density (Amplitude).

14.4.3. GAINMIN and GAINMAX Parameters

GAINMIN & GAINMAX define the boundaries within the gain setting (Virtual Gain) is allowed to vary. Outside this range, the output is set in diagnostic low.

14.5. FILTER

| Parameter | Value | Unit |
|-----------|----------|------|
| FHYST | 0 ... 11 | deg |
| FILTER | 0... 6 | |
| FSWAP | 0 1 | |

The MLX90324 includes 3 types of filters:

- Hysteresis Filter: programmable by the FHYST parameter
- Low Pass FIR Filters controlled with the Filter parameter
- Low Pass IIR Filter

Note: if the parameter FSWAP is set to “1”, the filtering is active on the digital angle. If set to “0”, the filtering is active on the output transfer function.

14.5.1. Hysteresis Filter

The FHYST parameter is a hysteresis filter. The output value of the IC is not updated when the digital step is smaller than the programmed FHYST parameter value. The output value is modified when the increment is bigger than the hysteresis. The hysteresis filter reduces therefore the resolution to a level compatible with the internal noise of the IC. The hysteresis must be programmed to a value close to the noise level.

Please note that for the programmable version, the FHYST parameter is set to 4 by default. If you do not wish this feature, please set it to “0”.

14.5.2. FIR Filters

The MLX90324 features 6 FIR filter modes controlled with Filter = 0...5. The transfer function is described below:

$$y_n = \frac{1}{\sum_{i=0}^j a_i} \sum_{i=0}^j a_i x_{n-i}$$

The characteristics of the filters no 0 to 5 is given in the Table 1.

| Filter No (j) | 0 | 1 | 2 | 3 | 4 | 5 |
|------------------------------|-----------|-------------------------|--------|--------|--------|--------|
| Type | Disable | Finite Impulse Response | | | | |
| Coefficients $a_0 \dots a_5$ | N/A | 110000 | 121000 | 133100 | 111100 | 122210 |
| Title | No Filter | Extra Light | | Light | | |
| 90% Response Time | 1 | 2 | 3 | 4 | 4 | 5 |
| 99% Response Time | 1 | 2 | 3 | 4 | 4 | 5 |
| Efficiency RMS (dB) | 0 | 2.9 | 4.0 | 4.7 | 5.6 | 6.2 |
| Efficiency P2P (dB) | 0 | 2.9 | 3.6 | 5.0 | 6.1 | 7.0 |

Table 1 - FIR Filters Selection Table



Figure 10 - Step Response and Noise Response for FIR (No 3) and FHYST=10

14.5.3. IIR Filters

The IIR Filter is enabled with Filter = 6. The diagram of the IIR Filter implemented in the MLX90324 is given in Figure 11.



Figure 11 - IIR Diagram

| Filter No | 6 |
|---------------------|---|
| Type | 2 nd Order Infinite Impulse Response (IIR) |
| Title | Medium |
| 90% Response Time | 11 |
| Efficiency RMS (dB) | 9.9 |
| Efficiency P2P (dB) | 12.9 |
| Coefficient A1 | 26112 |
| Coefficient A2 | 10752 |

Table 2 - IIR Filter

The Figure 12 shows the response of the filter to a Gaussian noise.

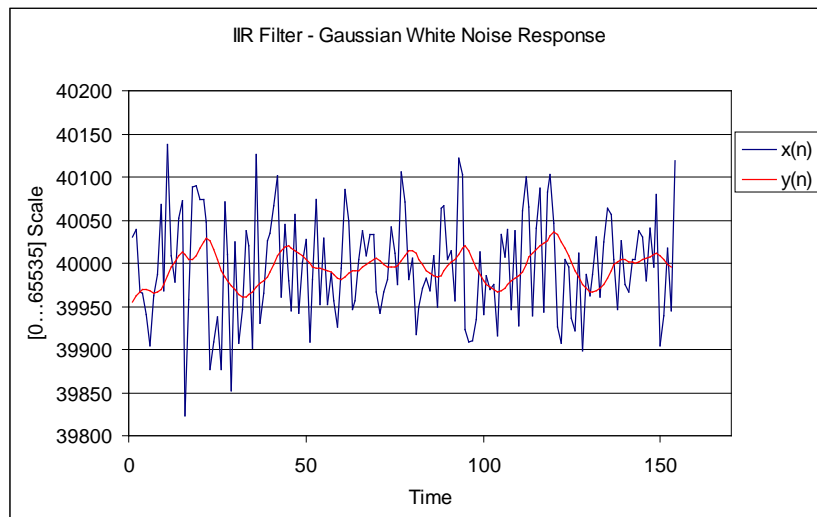

Figure 12 - Noise Response for the IIR Filter

14.6. Programmable Diagnostic Settings

| Parameter | Value | Unit |
|------------|-------|------|
| RESONFAULT | 0 | |
| | 1 | |
| EEHAMHOLE | 0 | |
| | 3131h | |

14.6.1. RESONFAULT Parameter

This RESONFAULT parameter enables the soft reset when a fault is detected by the CPU when the parameter is set to 1. By default, the parameter is set to “0” but it is recommended to set it to “1” to activate the self diagnostic modes (See section 15).

Note that in the User Interface (MLX90324UI), the RESONFAULT is split in two bits:

- DRESONFAULT: disable the reset in case of a fault.
- DOUTINFALT: disable output in diagnostic low in case of fault.

14.6.2. EEHAMHOLE Parameter

The EEHAMHOLE parameter disables the memory recovery (Hamming code) check when a fault is detected by the CRC when it is equal to 3131h. By default the parameter is set to 0 (enable memory recovery).

14.7. Lock

| Parameter | Value | Unit |
|-----------|-------|------|
| MLXLOCK | 0 | |
| | 1 | |
| LOCK | 0 | |
| | 1 | |

14.7.1. MLXLOCK Parameter

MLXLOCK locks all the parameters set by Melexis.

14.7.2. LOCK Parameter

LOCK locks all the parameters set by the user. Once the lock is enabled, it is not possible to change the EEPROM values anymore.

Note that the lock bit should be set by the solver function “MemLock”.

15. MLX90324 Self Diagnostic

The MLX90324 provides numerous self-diagnostic features. Those features increase the robustness of the IC functionality as it will prevent the IC to provide erroneous output signal in case of internal or external failure modes (“fail-safe”).

| | Action | Effect on Outputs | Remark |
|--|---|--------------------------------|---|
| ROM CRC Error at start up (64 words including Intelligent Watch Dog - IWD) | CPU Reset ⁽¹⁸⁾ | Diagnostic low ⁽¹⁹⁾ | All the outputs are already in Diagnostic low - (start-up) |
| ROM CRC Error (Operation - Background task) | Enter Endless Loop: - Progress (watchdog Acknowledge) - Set Outputs in Diagnostic low | Immediate Diagnostic low | |
| RAM Test Fail (Start up) | CPU Reset | Diagnostic low | All the outputs are already in Diagnostic low (start-up) |
| Calibration Data CRC Error (Start-Up) | Hamming Code Recovery | | Start-Up Time is increased by 3 ms if successful recovery |
| Hamming Code Recovery Error (Start-Up) | CPU Reset | Immediate Diagnostic low | See 14.6.2 |
| Calibration Data CRC Error (Operation - Background) | CPU Reset | Immediate Diagnostic low | |
| Dead Zone | Set Outputs in Diagnostic low. Normal Operation until the “dead zone” is left. | Immediate Diagnostic low | Immediate recovery if the “dead zone” is left |
| ADC Clipping (ADC Output is 0000h or 7FFFh) | Set Outputs in Diagnostic low Normal mode and CPU Reset If recovery | Immediate Diagnostic low | |
| Radius Overflow (> 100%) or Radius Underflow (< 40 %) | Set Outputs in Diagnostic low Normal mode and CPU Reset If recovery | Immediate Diagnostic low | (40 % - 100 %) No magnet / field too high See also 14.4.2 |
| Gain Too Low (The current gain code is strictly less than GAINMIN) | Set Outputs in Diagnostic low Normal mode, and CPU Reset If recovery | Immediate Diagnostic low | |
| Gain Too High (The current gain code is strictly greater than GAINMAX) | Set Outputs in Diagnostic low Normal mode, and CPU Reset If recovery | Immediate Diagnostic low | |
| Redundant Temperature Sensor Mismatch | Set Outputs in Diagnostic low Normal mode, and CPU Reset If recovery | Immediate Diagnostic low | |
| DAC Monitor (Digital to Analog converter) | Set Outputs in Diagnostic low. Normal Mode with immediate recovery without CPU Reset | Immediate Diagnostic low | |

MLX90324 Fault Mode continues...

¹⁸ CPU reset means

1. Core Reset (same as Power-On-Reset). It induces a typical start up time.
2. Periphery Reset (same as Power-On-Reset)
3. Fault Flag/Status Lost
4. The reset can be disabled by clearing the RESONFAULT bit (See 14.6.1)

¹⁹ Refer to section 7 for the Diagnostic Output Level specifications

| <i>...MLX90324 Fault Mode</i> | | | |
|---|--|--|--|
| Fault Mode | Action | Effect on Outputs | Remark |
| ADC Monitor (Analog to Digital Converter) | Set Outputs in Diagnostic low. Normal Mode with immediate recovery without CPU Reset | Immediate Diagnostic low | ADC Inputs are Shorted |
| Undervoltage Mode | At Start-Up, wait Until VDD > 3V. During operation, CPU Reset after 3 ms debouncing | - VDD < POR level => Outputs high impedance - POR level < VDD < 3 V => Outputs in Diagnostic low. | |
| Firmware Flow Error | CPU Reset | Immediate Diagnostic low | Intelligent Watchdog (Observer) |
| Read/Write Access out of physical memory | CPU Reset | Immediate Diagnostic low | 100% Hardware detection |
| Write Access to protected area (IO and RAM Words) | CPU Reset | Immediate Diagnostic low | 100% Hardware detection |
| Unauthorized entry in “SYSTEM” Mode | CPU Reset | Immediate Diagnostic low | 100% Hardware detection |
| VDD > 7 V | Set Output High Impedance (Analog) | Pull down resistive load => Diag. Low Pull up resistive load => Diag. High ⁽¹⁹⁾ | 100% Hardware detection |
| VDD > 9.4 V | IC is switched off (internal supply) CPU Reset on recovery | Pull down resistive load => Diag. Low Pull up resistive load => Diag. High | 100% Hardware detection |
| Broken VSS | CPU Reset on recovery | Pull down resistive load => Diag. Low Pull up resistive load => Diag. High | Pull down load ($\leq 10k\Omega$) to VSS to meet Diag Lo spec < 4% VDD. Trivial |
| Broken VDD | CPU Reset on recovery | Pull down resistive load => Diag. Low Pull up resistive load => Diag. High | Trivial Pull up load ($\leq 10k\Omega$) to VPULLUP \geq VDD to meet Diag Hi spec > 96% VDD. |

16. SENT (SAE-J2716) Protocol

16.1. Introduction

The MLX90324 features an output mode reporting the angular information and other diagnostic information (e.g. CRC) into a SENT telegram compliant with the approved SAE-J2716 Surface Vehicle Information Report.

SENT stands for Single Edge Nibble Transmission as the SENT telegram consists into the transmission of 8 Nibbles (1 nibble = 4 bits) in a row, each nibble being coded in a PWM (Pulse Width Modulation) way with reference to the falling edge.

The Single Edge Nibble Transmission encoding scheme is intended for use in applications where high resolution sensor data needs to be communicated from a sensor to an Electronic Control Unit (ECU). It is intended as a replacement for the lower resolution methods of 10 bit A/D's and PWM.

SENT is a point-to-point (i.e. it is not a data bus) unidirectional communications scheme from sensor (transmitting device) to controller (receiving device) which does not include a coordination signal from the controller/receiving device. The sensor signal is transmitted as a series of pulses with data measured as falling to falling edge times. Transmission occurs independently of any action of the receiver module, i.e. the transmission does not require a synchronization signal from the receiver module.

16.2. SENT Protocol Definition

The encoding scheme consists of a sequence of pulses which is repeatedly sent by the transmitting module.

The time granularity of the transmission is defined as the Clock Tick which is specified as follows:

$$3 \mu\text{s} \leq \text{Clock Tick} \leq 10 \mu\text{s}$$

Each nibble is defined in a PWM way:

- the output is first driven LOW (falling edge) for **5 Clock Ticks**,
- then driven HIGH for **7 Clock Ticks + n × Clock Ticks** where n is the decimal value of the nibble.

For a nibble value of 0 (minimum), the output is driven LOW for 5 Clock Ticks then driven HIGH for 7 Clock Ticks. Total period for the shortest nibble (n = 0) is therefore 12 Clock Ticks. See Figure 13.

For a nibble value of 15 (maximum), the output is driven LOW for 5 Clock Ticks then driven HIGH for 22 Clock Ticks. Total period for the longest nibble (n = 15) is therefore 27 Clock Ticks. See Figure 14.



Figure 13 – Timing Diagram for Nibble Value = 0d



Figure 14 – Timing Diagram for Nibble Value = 15d

| Nibble Value | | Output LOW (# Clock Ticks) | Output HIGH (# Clock Ticks) | Nibble Period (# Clock Ticks) |
|--------------|--------|-------------------------------|--------------------------------|----------------------------------|
| Decimal (n) | Binary | | | |
| 0d | 0000b | 5 | 7 | 12 |
| 1d | 0001b | 5 | 8 | 13 |
| 2d | 0010b | 5 | 9 | 14 |
| 3d | 0011b | 5 | 10 | 15 |
| 4d | 0100b | 5 | 11 | 16 |
| 5d | 0101b | 5 | 12 | 17 |
| 6d | 0110b | 5 | 13 | 18 |
| 7d | 0111b | 5 | 14 | 19 |
| 8d | 1000b | 5 | 15 | 20 |
| 9d | 1001b | 5 | 16 | 21 |
| 10d | 1010b | 5 | 17 | 22 |
| 11d | 1011b | 5 | 18 | 23 |
| 12d | 1100b | 5 | 19 | 24 |
| 13d | 1101b | 5 | 20 | 25 |
| 14d | 1110b | 5 | 21 | 26 |
| 15d | 1111b | 5 | 22 | 27 |

The transmission itself consists of the following sequence:

- “Calibration/Synchronization” pulse period 56 Clock Ticks
- One “Status and Communication” nibble pulse (Nibble #1)
- A sequence of six “Data” nibble pulses (Nibble #2 ... #7)
- One “Checksum” (CRC) nibble pulse (Nibble #8)

Figure 15 shows a single message transmission for which

- Nibble #1 = 0d
- Nibble #2 = 15d
- Nibble #3 = 0d
- Nibble #4 = 8d
- Nibble #5 = 15d
- Nibble #6 = 0d
- Nibble #7 = 8d
- Nibble #8 = 12d (for example purpose – please note that this nibble may not necessarily match the CRC definition)



Figure 15 – Single SENT Message Transmission

The transmission delay of one message depends on the content of the nibbles but the minimum and maximum boundaries are 152 Clock Ticks (456 μ s if Clock Tick = 3 μ s) and 272 Clock Ticks (816 μ s if Clock Tick = 3 μ s).

The “Calibration/Synchronization” pulse period is measured by the receiver in order to calculate the actual duration of the Clock Tick. In this way, the frequency variations of the main oscillator at the transmitter (i.e. the sensor) can be compensated. The allowable frequency variation is $\pm 20\%$.

The “Status and Communication” nibble is used to transmit internal status or diagnostic information. The content varies according to the SENT implementation (see Section 16.3 for the implemented SENT version of MLX90324).

The “Checksum” nibble contains a 4 bit CRC of the Data nibbles only. The “Status and Communication Nibble” is not included in the CRC calculation. The CRC is calculated using polynomial $x^4 + x^3 + x^2 + 1$ with seed value of 0101.

16.3. SENT Protocol Implementation

The MLX90324 implements the Single Secure Sensors format described in the Appendix (Section A.3) of SAE-J2716 definition.

The Clock Tick is specified at 3 μ s.

The angular information (12 bits) is spread over 3 data nibbles. A 8-bit rolling counter 0 to 255 with rollover back to 0 is included in 2 data nibbles. The last data nibble is derived from the 1st data nibble including the MSBs (Most Significant Bits) of the computed angle.

- Nibble #1 = “Status” Nibble
 - When the sensor is determined to be faulted, Bit 0 of the Status Nibble is set to 1 otherwise bit set to 0
 - Bit 1, Bit 2 and Bit 3 are set to 0.
- Nibble #2 = Angular Information – MSN (Most Significant Nibble)
- Nibble #3 = Angular Information – MidN (Middle Nibble)
- Nibble #4 = Angular Information – LSN (Least Significant Nibble)
- Nibble #5 = 8 bit rolling counter – MSN (Most Significant Nibble)
- Nibble #6 = 8 bit rolling counter – LSN (Least Significant Nibble)
- Nibble #7 = Inverted copy of Nibble #2 (15 – Nibble #2 value)
- Nibble #8 = “Checksum” Nibble

The rolling counter can be disabled (to match the “single sensor” format of the Appendix A.4 of the SAE-J2716): in this case, Nibble #5 and Nibble #6 are set to 0. See in the End-User programmable item to see how to disable it (Section 14.1.3)

16.4. Use of the MLX90324 SENT Feature

In order to enable the SENT output reporting mode, specific parameters (stored in EEPROM) of the MLX90324 needs to be programmed. While using the Melexis programming tools, the whole operation is actually controlled through a single item as described on Section 14.1.3.

The SAE-J2716 recommends a generic application diagram for both the transmitter and the receiver in order to pass the EMC norms, especially the emissions (e.g. radiated emission, conducted emission) requirements.

This recommended circuitry applied to the MLX90324LDC (single die – SOIC-8) is shown at the Section 17.4 and MLX90324LGO (dual die – TSSOP-16) is shown at the Section 17.5.

17. Recommended Application Diagrams

17.1. Analog Output Wiring with the MLX90324 in SOIC Package



Figure 16 – Recommended wiring for the MLX90324 in SOIC8 package⁽²⁰⁾.

²⁰ See section 14.1.4 if the Switch Output feature is used.

17.2. Analog Output Wiring with the MLX90324 in TSSOP Package



Figure 17 – Recommended wiring for the MLX90324 in TSSOP16 package (dual die).

17.3. PWM Low Side Output Wiring



Figure 18 – Recommended wiring for a PWM Low Side Output configuration⁽²¹⁾.

²¹ See section 14.1.4 if the Switch Output feature is used.

17.4. SENT Output Wiring with the MLX90324 in SOIC-8 package



Figure 19 – Recommended Application Diagram for the Transmitter & Receiver

17.5. SENT Output Wiring with the MLX90324 in TSSOP-16 package

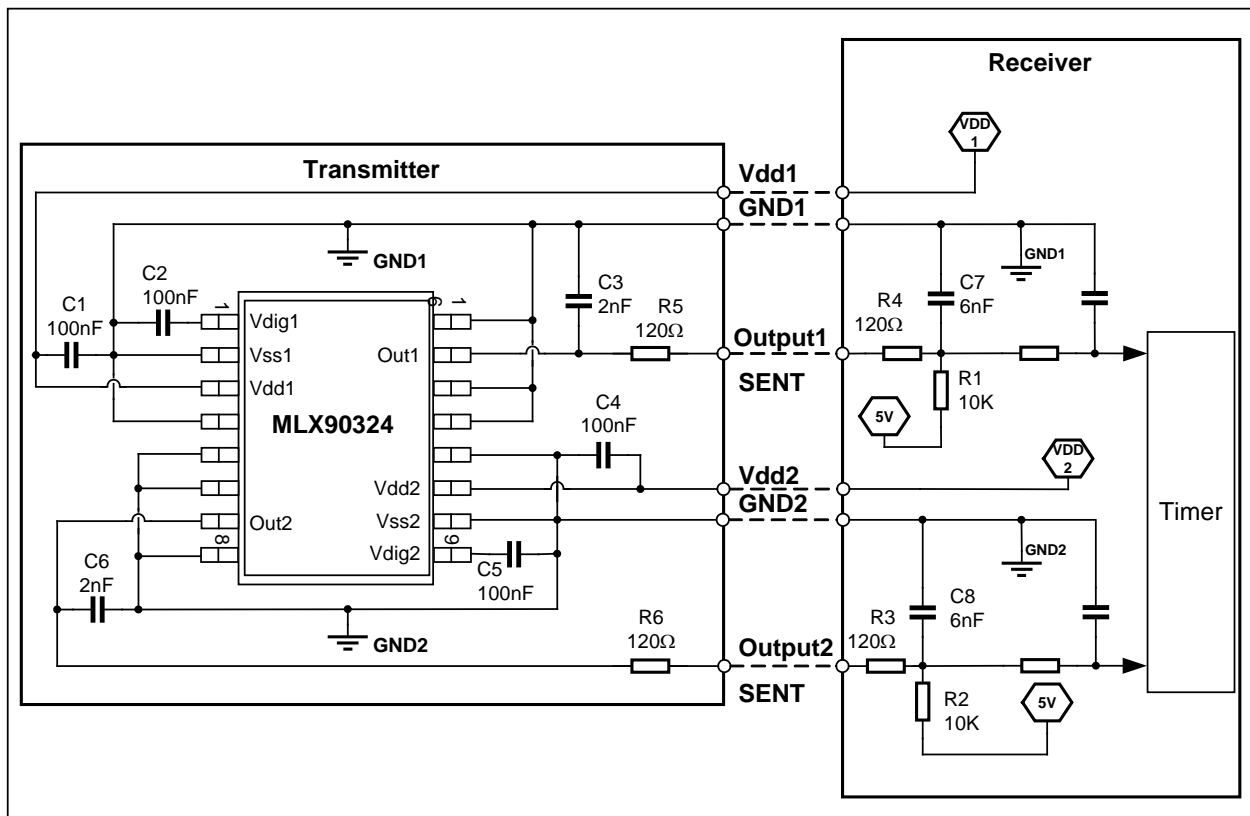

Figure 20 – Recommended Application Diagram for the Transmitter & Receiver in TSSOP package

18. Standard information regarding manufacturability of Melexis products with different soldering processes

Our products are classified and qualified regarding soldering technology, solderability and moisture sensitivity level according to following test methods:

Reflow Soldering SMD's (Surface Mount Devices)

- IPC/JEDEC J-STD-020
Moisture/Reflow Sensitivity Classification for Nonhermetic Solid State Surface Mount Devices (classification reflow profiles according to table 5-2)
- EIA/JEDEC JESD22-A113
Preconditioning of Nonhermetic Surface Mount Devices Prior to Reliability Testing (reflow profiles according to table 2)

Wave Soldering SMD's (Surface Mount Devices) and THD's (Through Hole Devices)

- EN60749-20
Resistance of plastic- encapsulated SMD's to combined effect of moisture and soldering heat
- EIA/JEDEC JESD22-B106 and EN60749-15
Resistance to soldering temperature for through-hole mounted devices

Iron Soldering THD's (Through Hole Devices)

- EN60749-15
Resistance to soldering temperature for through-hole mounted devices

Solderability SMD's (Surface Mount Devices) and THD's (Through Hole Devices)

- EIA/JEDEC JESD22-B102 and EN60749-21
Solderability

For all soldering technologies deviating from above mentioned standard conditions (regarding peak temperature, temperature gradient, temperature profile etc) additional classification and qualification tests have to be agreed upon with Melexis.

The application of Wave Soldering for SMD's is allowed only after consulting Melexis regarding assurance of adhesive strength between device and board.

Melexis recommends reviewing on our web site the General Guidelines [soldering recommendation](http://www.melexis.com/Quality_soldering.aspx) (http://www.melexis.com/Quality_soldering.aspx) as well as [trim&form recommendations](http://www.melexis.com/Assets/Trim-and-form-recommendations-5565.aspx) (<http://www.melexis.com/Assets/Trim-and-form-recommendations-5565.aspx>).

Melexis is contributing to global environmental conservation by promoting **lead free** solutions. For more information on qualifications of **RoHS** compliant products (RoHS = European directive on the Restriction Of the use of certain Hazardous Substances) please visit the quality page on our website: <http://www.melexis.com/quality.aspx>

19. ESD Precautions

Electronic semiconductor products are sensitive to Electro Static Discharge (ESD). Always observe Electro Static Discharge control procedures whenever handling semiconductor products.

20. Package Information

20.1. SOIC8 - Package Dimensions



20.2. SOIC8 - Pinout and Marking



20.3. SOIC8 - IMC Positioning



Angle detection MLX90324 SOIC8

~ 0 Deg.*



~ 90 Deg.*



~ 180 Deg.*



~ 270 Deg.*



* No absolute reference for the angular information.

The MLX90324 is an absolute angular position sensor but the linearity error (Le – See Section 10) does not include the error linked to the absolute reference 0 Deg (which can be fixed in the application through the discontinuity point – See 14.2.2).

20.4. TSSOP16 - Package Dimensions

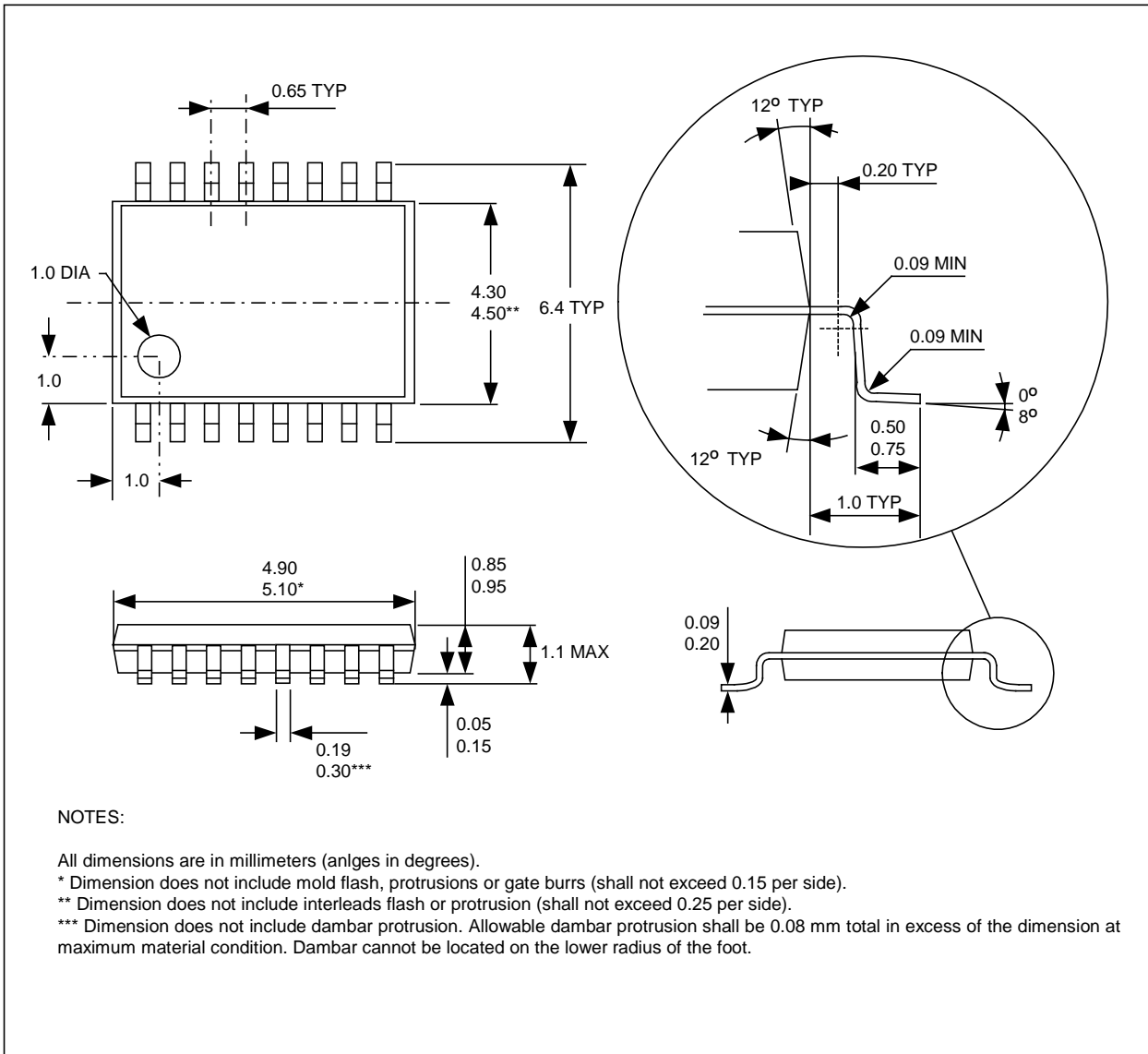

20.5. TSSOP16 - Pinout and Marking



20.6. TSSOP16 - IMC Positioning

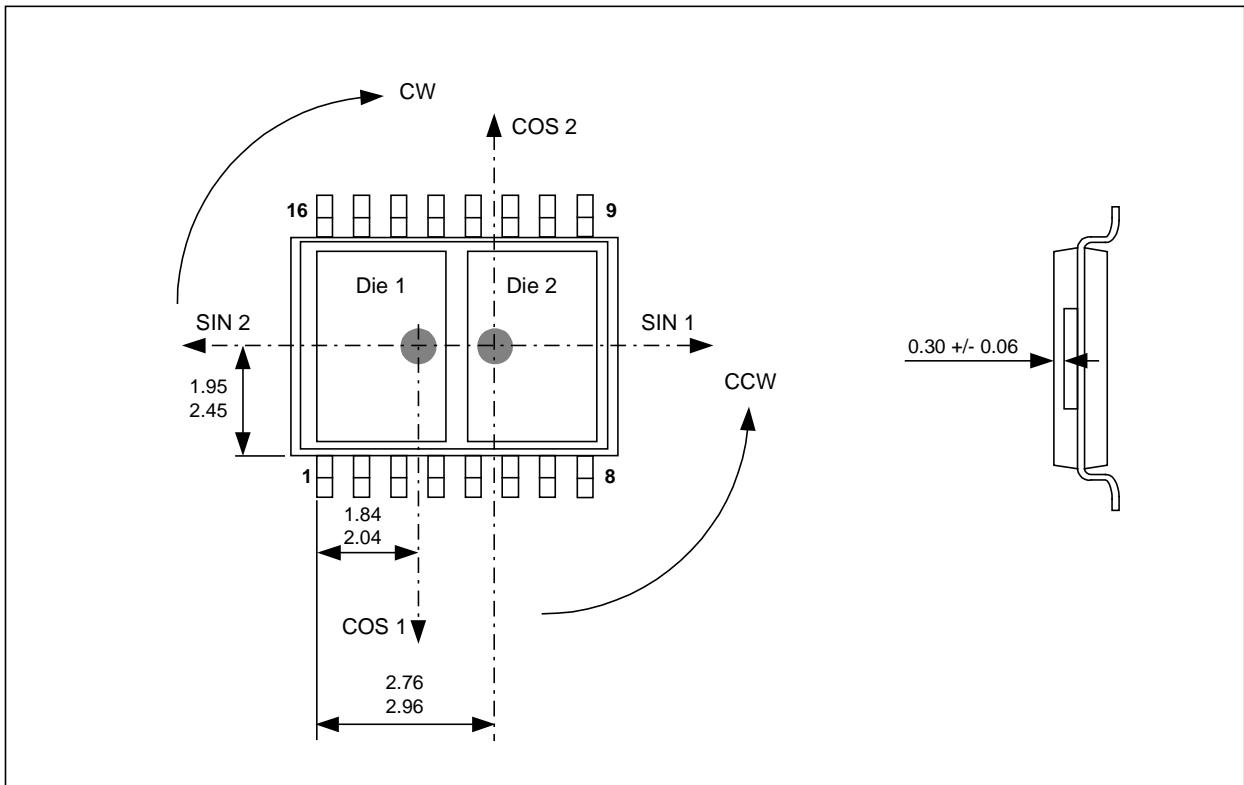



The MLX90324 is an absolute angular position sensor but the linearity error (Le – See Section 10) does not include the error linked to the absolute reference 0 Deg (which can be fixed in the application through the discontinuity point – See 14.2.2).

21. Disclaimer

The information furnished by Melexis herein (“Information”) is believed to be correct and accurate. Melexis disclaims (i) any and all liability in connection with or arising out of the furnishing, performance or use of the technical data or use of the product(s) as described herein (“Product”) (ii) any and all liability, including without limitation, special, consequential or incidental damages, and (iii) any and all warranties, express, statutory, implied, or by description, including warranties of fitness for particular purpose, non-infringement and merchantability. No obligation or liability shall arise or flow out of Melexis’ rendering of technical or other services.

The Information is provided “as is” and Melexis reserves the right to change the Information at any time and without notice. Therefore, before placing orders and/or prior to designing the Product into a system, users or any third party should obtain the latest version of the relevant information to verify that the information being relied upon is current.

Users or any third party must further determine the suitability of the Product for its application, including the level of reliability required and determine whether it is fit for a particular purpose.

The Information is proprietary and/or confidential information of Melexis and the use thereof or anything described by the Information does not grant, explicitly or implicitly, to any party any patent rights, licenses, or any other intellectual property rights.

This document as well as the Product(s) may be subject to export control regulations. Please be aware that export might require a prior authorization from competent authorities.

The Product(s) are intended for use in normal commercial applications. Unless otherwise agreed upon in writing, the Product(s) are not designed, authorized or warranted to be suitable in applications requiring extended temperature range and/or unusual environmental requirements. High reliability applications, such as medical life-support or life-sustaining equipment are specifically not recommended by Melexis. The Product(s) may not be used for the following applications subject to export control regulations: the development, production, processing, operation, maintenance, storage, recognition or proliferation of 1) chemical, biological or nuclear weapons, or for the development, production, maintenance or storage of missiles for such weapons; 2) civil firearms, including spare parts or ammunition for such arms; 3) defense related products, or other material for military use or for law enforcement; 4) any applications that, alone or in combination with other goods, substances or organisms could cause serious harm to persons or goods and that can be used as a means of violence in an armed conflict or any similar violent situation.

The Products sold by Melexis are subject to the terms and conditions as specified in the Terms of Sale, which can be found at <https://www.melexis.com/en/legal/terms-and-conditions>.

This document supersedes and replaces all prior information regarding the Product(s) and/or previous versions of this document.

Melexis NV © - No part of this document may be reproduced without the prior written consent of Melexis. (2017)

ISO/TS 16949 and ISO14001 Certified

For the latest version of this document, go to our website at
www.melexis.com

Or for additional information contact Melexis Direct:

| | |
|--|--|
| Europe, Africa, Asia: | America: |
| Phone: +32 1367 0495 | Phone: +1 248 306 5400 |
| E-mail: sales_europe@melexis.com | E-mail: sales_usa@melexis.com |

ISO/TS 16949 and ISO14001 Certified