

THIS DOCUMENT IS THE PROPERTY OF  
KEYSTONE ELECTRONICS CORP. AND  
SHALL NOT BE REPRODUCED, DISTRIBUTED  
OR USED AS A BASIS FOR MANUFACTURE  
WITHOUT PRIOR WRITTEN PERMISSION  
FROM KEYSTONE ELECTRONICS CORP.

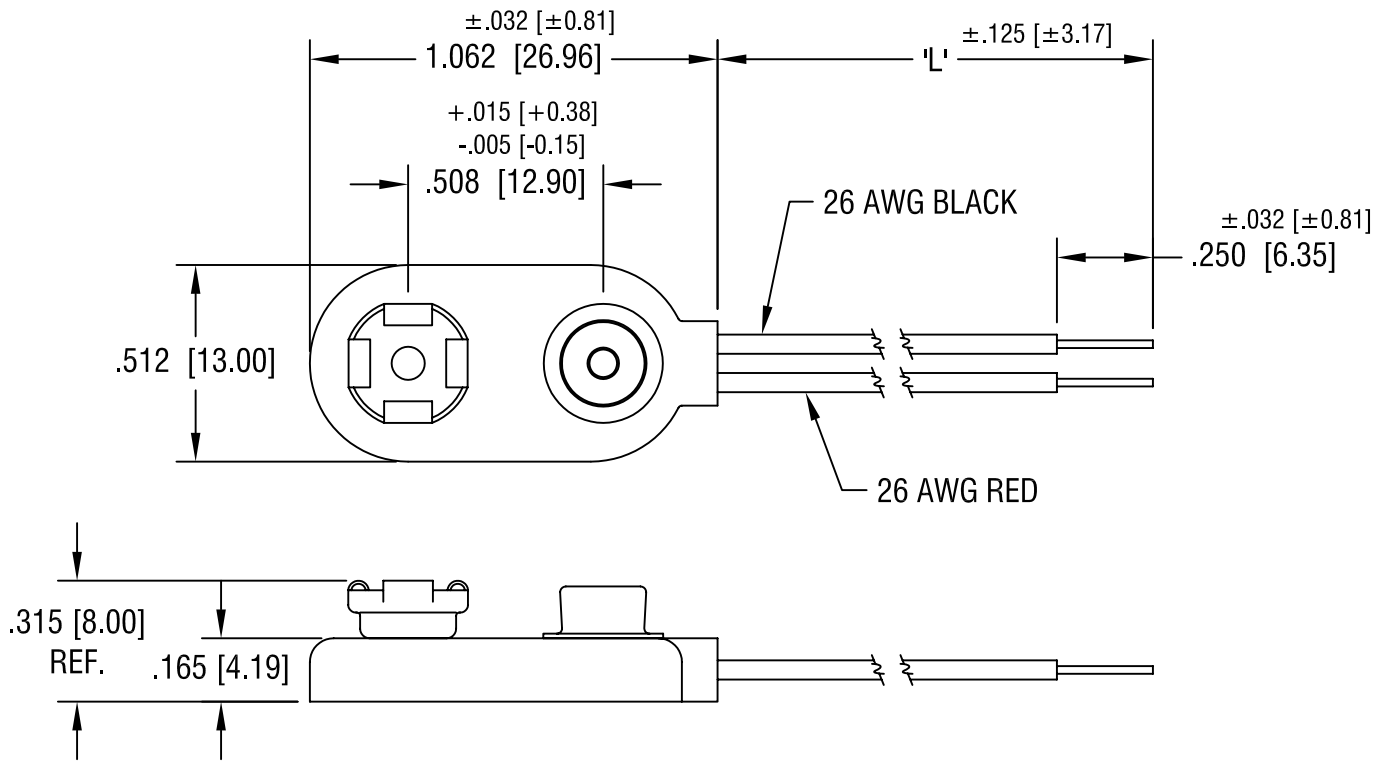

**NOTE:**

- 1. MAT'L - WIRE: 26 AWG, 1007 UL/CSA APPROVED
- CONTACTS: PHOSPHOR BRONZE, NICKEL PLATE
- BODY: MOLDED POLYETHYLENE
- RED WIRE CONNECTED TO FEMALE CONTACT;
- BLACK WIRE CONNECTED TO MALE CONTACT.

PART NO.	'L' DIM.
2238	4.000 [101.60]
2239	6.000 [152.40]
2240	8.000 [203.20]

3.10.05	CHANGE AS PER ECN 05-016	A
DATE	DESCRIPTION	REV.

**KEYSTONE ELECTRONICS CORP.**  
ASTORIA, N.Y. 11105-2017

PART NAME PREMIUM '9' VOLT 'I' STYLE BATTERY STRAP	
MATERIAL AS NOTED	
FINISH AS NOTED	DRN BY BOONE
	DATE 8.8.95
	APP'D LN
	SCALE 2X
TOLERANCES INCH [MM] DECIMAL ±.020 [±0.50] ANGULAR ± 1° UNLESS OTHERWISE SPECIFIED	CODE C/M
DWG NO. <b>2238-2240</b>	