

BLuAC5

Hardware Manual



BLuAC5-S
BLuAC5-SE
BLuAC5-Q
BLuAC5-QE



920-0049 Rev. C
12/8/2014

Contents

Introduction.....	4
Block Diagram	5
Getting Started	6
Status & Error Display LEDs	7
Serial Comm Tx & Rx LED	7
Bus voltage indication LED.....	7
Seven Segment Display Error codes.....	8
Seven Segment Display Status codes.....	9
Connecting to the PC using RS-232.....	10
Regeneration LED.....	10
Connecting to a host using RS-485.....	11
A Short tutorial on RS-485 & RS-422.....	11
Getting and Connecting a RS485 4-wire adaptor to your PC.....	12
Getting and Connecting a RS485 2-wire adaptor to your PC.....	13
Before you connect the servo drive to your system	13
Connecting the AC Power Input.....	14
24 Volt Controller Input (Keep Alive).....	14
Connecting Single Phase AC input (90-260VAC).....	15
Connecting 3-Phase AC input (90-260VAC).....	15
Connecting the Motor	16
Recommended Ferrite Core Instructions.....	17
Fuses - External and Internal	17
Line Filters	17
Connecting the Encoder & Hall Sensors	18
Encoder Pinout.....	18
Connecting a Single-Ended Encoder	19
Connecting Single-Ended Hall Sensors	19
IN/OUT 1 Connector.....	20
Summary of Input Signals	20
IN/OUT 1 Connector Pin Diagram	20
High Speed Digital Inputs.....	21
Using High Speed Inputs with 12-24 Volt Signals.....	22
Connecting to PLC with Sourcing (PNP) Outputs	23
Connecting to PLC with Sinking (NPN) Outputs.....	23
Using Mechanical Switches at 24 Volts.....	23
Standard Digital Inputs	24
What is COM?	24
User Out 24V supply	24
Digital Input Connection Examples.....	25

Connecting Limit Switches to the BLUAC5 Drives.....	26
BLuAC5 Limit Input diagram	26
Wiring a Mechanical Limit Switch	27
Wiring a Limit Sensor	27
Analog Inputs.....	28
Three dedicated purposes:.....	28
Basic Specifications:.....	28
Wiring a controller with differential output as a singled ended input.....	29
Wiring a controller with differential output to differential input	29
Wiring a potentiometer to a singled ended input	29
Programmable Outputs.....	30
Encoder Outputs.....	31
IN/OUT2 Connector (-SE and -QE only)	32
Single Ended Inputs	32
Differential Inputs.....	32
Connecting to the Analog Input on the IN/OUT 2 Connector	33
Programmable Outputs on the IN/OUT 2 Connector.....	34
Recommended AMP Motors	36
Alpha A Series.....	36
M Series	36
N Series.....	36
J Series.....	36
Other Supplier's Motors	37
Setting Drive Current Limits.....	38
What is "Peak Current Limit"?	38
Using DC Brushed Motors.....	39
Servo Drive Regeneration	40
Wiring Integral Holding Brakes	41
Mounting the Drive	43
Mechanical Outline	43
Technical Specifications	44
Mating Connectors and Accessories	44

Introduction

Thank you for selecting an Applied Motion Products motor control. We hope our dedication to performance, quality and economy will make your motion control project successful.

If there's anything we can do to improve our products or help you use them better, please call or fax. We'd like to hear from you. Our phone number is (800) 525-1609 or you can reach us by fax at (831) 761-6544. You can also email support@applied-motion.com.

Features

- Digital servo motor driver in complete fully featured package
- Operates directly from a 90 to 260Volt AC input
- Operates in torque, velocity or position mode
- Accepts analog signals, digital signals and RS-232/485 serial commands
- Motor current to 15 amps peak, 5 amps continuous
- Seven optically isolated digital inputs (15 inputs with expanded I/O board)
- Three optically isolated digital outputs (7 outputs with expanded I/O board)
- One differential or two single ended ± 10 volt analog inputs for position, speed and torque control. In the SCL and Q languages the analog inputs can be read and used to set other parameters.
- 0-5V aux analog input

Block Diagram

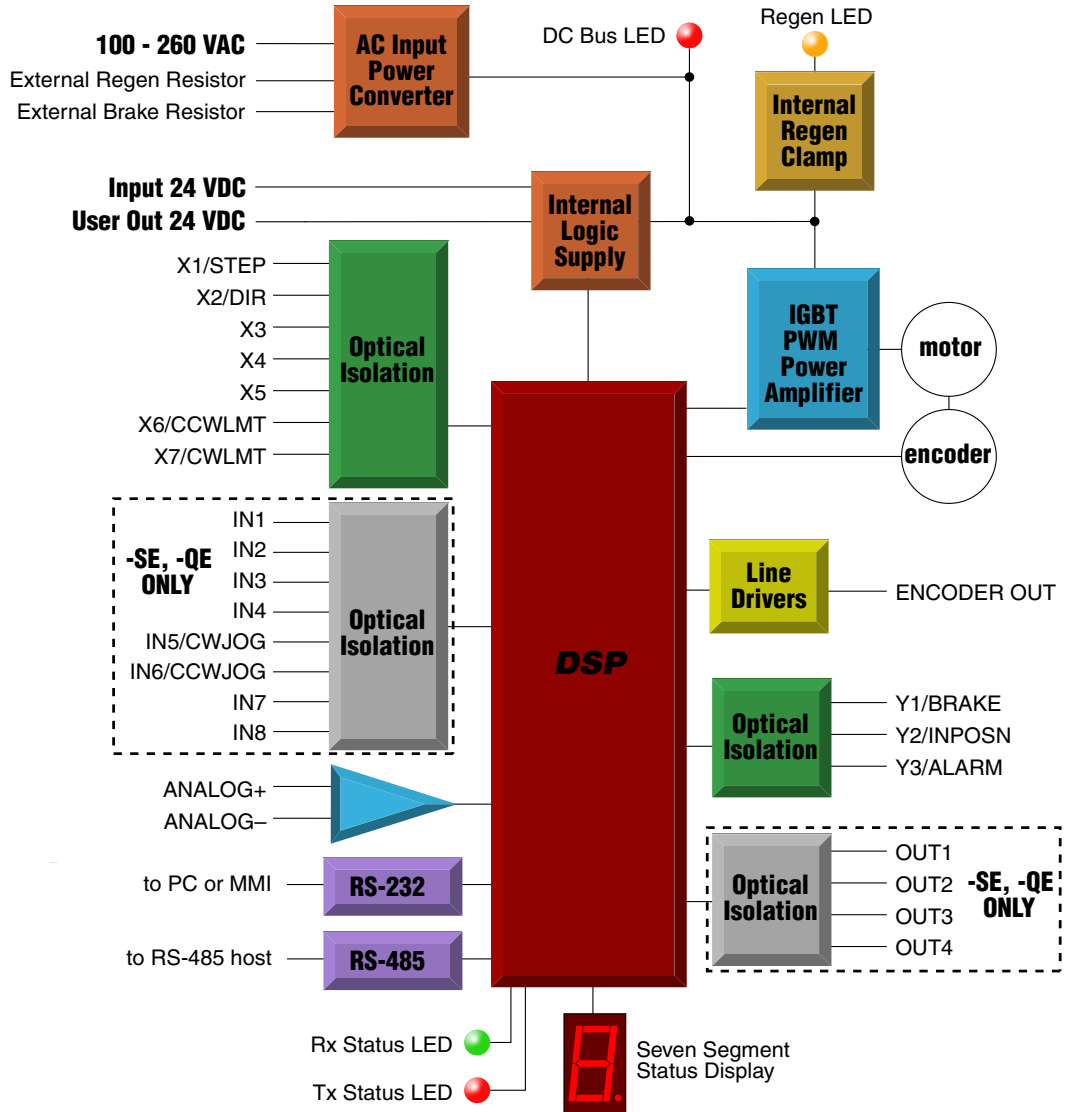

Getting Started

To use your BLuAC5 servo drive you must have the following:

- a compatible servo motor
- cables to connect the motor to the drive. If you are using an Applied Motion A, N or M motor, use BLUENC and BLUMTR-FA cables (one of each).
You must use an “FA” (filtered) motor cable for proper operation of the BLUAC.
J motor, use 3004-301-3M and 3004-307-3M cables (one of each).
- a small flat blade screwdriver for tightening the connectors (included).
- a personal computer running Microsoft Windows 98, NT, Me, 2000, XP or Vista.
- The Applied Motion CD that came with your drive.
- An Applied Motion programming cable (included)

If you’ve never used a BLU servo before, you’ll need to get familiar with the drive and the set up software before you try to deploy the system in your application. We strongly recommend the following:

1. Install the *Quick Tuner* software from the CD.
2. Launch the software by clicking Start...Programs...Applied Motion Products...Quick Tuner.
3. Connect the drive to your PC using the programming cable supplied.
4. Connect the drive to the AC power source (may be switched).
5. Connect the drive to the motor.
6. Apply power to the drive.
7. Follow the instructions in the *Quick Tuner* manual.

The connectors and other points of interest are illustrated on the next page. Depending on your drive model and application, you’ll need to make connections to various parts of the drive. These are detailed later in the manual.

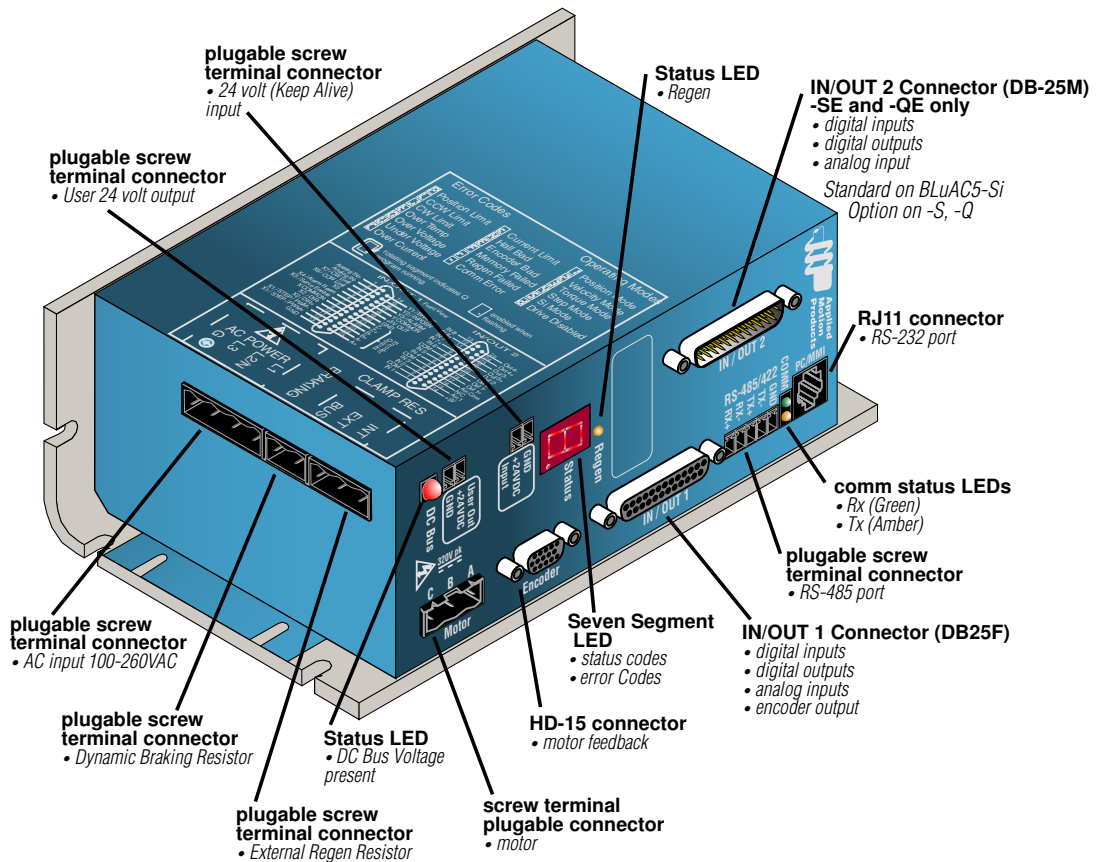

Always use the blue & white Applied Motion screwdriver to tighten the screw terminal connectors. Larger screwdrivers may remove the plastic dimples that prevent the screws from falling out.

Status & Error Display LEDs

Serial Comm Tx & Rx LED

Indicates that data is being received or transmitted through the RS-232 or RS-485 serial ports. Green indicates "Receiving". Red indicates "Transmitting"

Bus voltage indication LED

Indicates when there is DC Bus voltage present on the drive. Servo drive cover should not be removed when this LED is illuminated.

Seven Segment Display Error codes

Note: codes with a "*" indicate drive has faulted and flash at a 0.5 second rate.



***Position Limit Error:** Indicates the Servomotor has exceeded the "Position Limit" value.



CCW Limit: The Counter Clockwise limit has been triggered. This will depend on the CCW/CW Input settings. Use "DL" command to enable usage



CW Limit: The Clockwise limit has been triggered. This will depend on the CCW/CW Input settings. Use "DL" command to enable usage



***Over Temperature:** The Drive PCB temperature has exceeded 75° C. This will cause the drive to fault and cannot be cleared until the temperature drops below the



***Regeneration Error:** While attempting to "dump" power into the regeneration shunt resistor the device limits were reached or, there is no regeneration shunt resistor



***Over Voltage:** The DC Bus voltage exceeded 400 Volts. The drive will be faulted after this error.



Under Voltage: The DC Bus voltage has gone below 100 Volts. This does NOT fault the drive.



***Over Current:** The Motor phase current has exceeded the 20 amps (RMS). The drive will be faulted.



Current Limit: The Motor phase current has exceeded the "Peak" current time limit (As set by the CP command).



***Hall Pattern Bad:** Indicates that the Hall sensor (commutation track) inputs are incorrect. Drive only accepts 120° Hall sensor patterns. Could also indicate a failed



Cannot execute move: the most common cause of this alarm is when a move is commanded while the motor is disabled.



***Encoder Failure:** Indicates that the Encoder inputs are not providing the correct states. This feature can be enabled or disabled using the QuickTuner® Setup utility.



Memory Fault: When reading or writing to “Flash” memory an error occurred. This is an indicator of memory problems that are typically induced with too many write cycles (>100,000).



Memory Fault: Q segment could not be executed because it was blank.



Serial Comm Error: Indicates a Serial Communication error. This error is also indicated by the Comm Tx and Rx LEDs flashing an alternating pattern.



Serial Comm Timeout: A complete command packet was not received in the normal amount of time. This can happen if you try to type SCL or Q commands into *Hyper-terminal* instead of using the *SCL Utility*. It will also occur if your host application does not end each command with a carriage return (ASCII 13)

Seven Segment Display Status codes



Positioning Mode: The drive is in Positioning Mode. This is the mode used when performing “point to point” moves.



Velocity Mode: The drive is in Velocity Mode. This is the mode used when “Jogging” or Analog commanded Velocity.



Torque Mode: The drive is in Torque Control Mode. This is the mode used for Analog commanded Torque operation.



Step & Direction Mode: The drive is in Step and Direction Control Mode. This is the mode used for “Encoder Following” or Positioning using Step and Direction input.



Si Positioning: You should not see this code on a -S or -Q drive.



Drive Disabled: The drive output is disabled.



Q Program Running: An outside segment will be rotating around the display. The rotate rate is about 0.2 seconds per segment.



Drive Start-up test pattern: This pattern is displayed for a short period of time at drive start-up.

Regeneration LED

This LED indicates when the drive is actively applying the regeneration clamp. The clamp is the internal circuitry that shunts the DC bus to a power resistor. The power resistor can be either internal or external. (See “[Servo Drive Regeneration](#)” in this manual for more details)

Connecting to the PC using RS-232

- Locate your computer within 6 feet of the BLU servo drive.
- Your drive was shipped with a communication cable. Plug the large end into the serial port of your PC and the small end into the RS-232 jack on your drive. Secure the adapter to the PC with the screws on the sides.

Never connect a BLU servo drive to a telephone circuit. It uses the same connectors and cords as telephones and modems, but the voltages are not compatible.

If your PC does not have a serial port, you should purchase a “USB Serial Converter”. We have had good results with the Port Authority “USB Serial DB9” Adapter from CablesToGo.com and with the SW1301 from SewellDirect.com.

For laptops, a PCMCIA converter card is a good choice. Our applications engineers use the [SSP-100](#) from Sewell Direct.

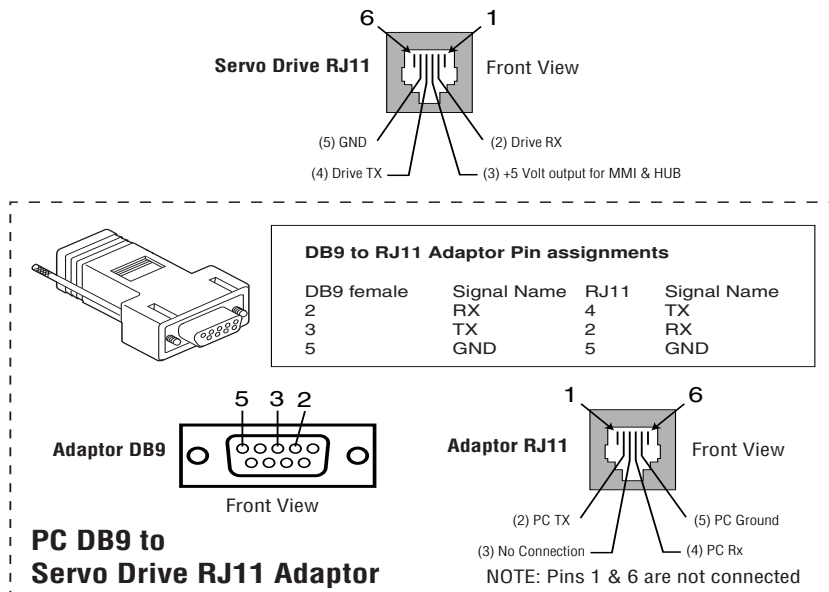

Connecting to a host using RS-485

RS-485/422 allows you to connect more than one drive to a single host PC, PLC or other computer. It also allows the communication cable to be long (more than 1000 feet). But the device to which you connect must have an RS-485/422 port.

A Short tutorial on RS-485 & RS-422

There is a bit of confusion on the implementation of these two serial interface specifications. RS-485 in the strictest definition is a “2-wire” interface that allows multi-node connections limited to “Half-duplex” serial communications. Up to 32 nodes that both transmit and receive can be connected to the network. RS-422 also in the strictest definition is a “4-wire” point to point connection that allows “Full-duplex” serial communications when connected to a single node. RS-422 has one node that is the driver or transmitter and up to 10 nodes that are receivers. RS-422 was not designed for a true multi-node network.

2-wire interfaces require one more significant feature. A network node, master or slave, must be able to tristate its transmitter to allow other nodes to use the network when required. For high speed baud rates this must be done very quickly to avoid communications collisions.

4-wire interfaces can go beyond the simple point to point and do multi-node networks if the slave nodes are capable of tri-stating their transmitters as required in the 2-wire networks. Some RS-485 devices are setup to do this and can be used in a 4-wire configuration.

On the AMP Servo drives the RS-485 can be implemented with either “2-wire” or “4-wire”. In both cases communications is still limited to “Half-duplex” because of the nature of the serial communications protocols used. 4-wire implementations can sometimes be easier due to the greater number of Host RS-232 to RS-485 adaptors that support the 4-wire interface. 2-wire implementations may require special Host adaptors that support “Auto enable” of the adaptor transmitter. This is because PC software typically doesn’t support tri-stating the output of the serial adaptors.

In both 2-wire and 4-wire systems one extra wire is always required to connect the “Grounds” of all the nodes on the network. Even though in both cases the signals are sent differentially, a common ground connection is absolutely required.

One more consideration must not be neglected. Proper cable shielding is a must. High voltage, high frequency, high current signals that are present on the servo motor cables can emit a significant amount of electrical interference. Without proper shielding these signals can disrupt even “noise tolerant” differential line drivers.

Our RS-485 implementation is a 4-wire multi-drop network with separate transmit and receive wires. One pair of wires connects from the host computer's TX+ and TX- signals to each drive's RX+ and RX- terminals. Another pair connects the TX+ and TX- drive terminals to the host computer's RX+ and RX- signals. A common ground terminal is provided on each drive and should be used to keep all drives at the same ground potential. Connect one drive's GND terminal to the host computer ground.

Before wiring the entire system, you'll need to connect each drive individually to the host computer so that a unique address can be assigned to each drive. Proceed as follows: (Also see figure #1 below)

1. Connect the drive TX+ to the PC's RX+ terminal.
2. Connect the drive TX- to PC RX-.
3. Connect RX+ to TX+.
4. Connect RX- to TX-.
5. Connect GND to GND.

Getting and Connecting a RS485 4-wire adaptor to your PC

Model 117701 from [Jameco Electronics](#) (800-831-4242) works well. This adaptor is for a 25 pin serial port. If you are like most people and have a 9 pin serial port on your PC, you will also need to purchase Jameco cable 31721. Connect as follows:

adaptor drive	
1	RX+
2	RX-
3	TX-
4	TX+

Set the switches for DCE and TxON,RxON. Don't forget to plug in the DC power adaptor that comes with the unit.

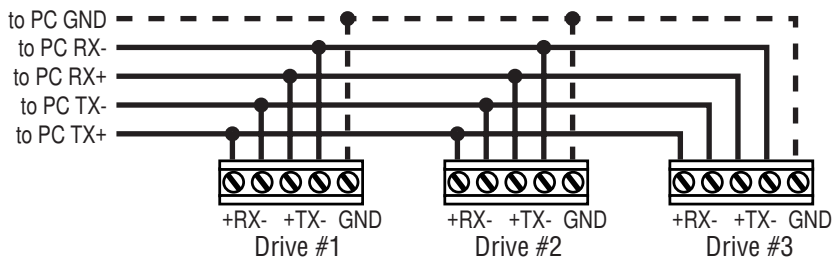

4-Wire RS-485 Figure #1

You can also connect the drive to the Host computer using only a 2-wire interface. In this case you must first connect the TX+ to the RX+ and the TX- to the RX- on the servo drives before connecting to the Host adaptor. Usually RS-485 2-wire interfaces are labeled "A" & "B".

Getting and Connecting a RS485 2-wire adaptor to your PC

Model 485-25E from [Integrity Instruments](#) (800-450-2001) works well. It comes with everything you need. Connect as follows:

adaptor drive	
B	TX+/RX+
A	TX-/RX-

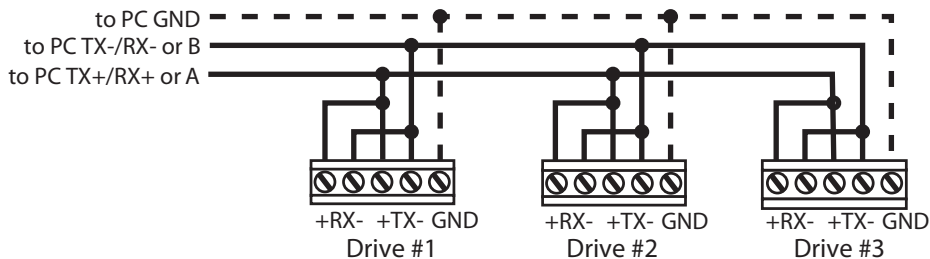

Before you connect the servo drive to your system

With the RS-232 cable connected between your PC and the Servo drive, on your PC, start the *SCL Setup Utility* software. Select the proper comm port (1,2,3 or 4) then apply power to the drive. Press the Caps Lock key. The drives only accept commands in uppercase. Type RV then press ENTER. If the drive has power and is properly wired, it will respond with "RV=x". Where x is the firmware version of your drive. If the drive responds, you're home free: the RS485 network is functioning.

Next, you must choose an address for this drive. Any of the "low ASCII" characters (many of which appear above the number keys on a PC keyboard) is acceptable: ! " # \$ % & ' () * + , - . / 0 1 2 3 4 5 6 7 8 9 ; : < > ? @

To find out what address is in the drive now, type DA then press enter. The drive will respond with DA=x, where x is the address that was last stored. (For example, the response might be DA=@ or DA=!). To change the address, type DAy, where y is the new address character, then press ENTER.

To test the new address, type yRV, then press ENTER. For example, if you set the address to % and want to test that, type %RV. The drive should respond just as it does to RV, the global revision level request.

Once all the drives have been assigned unique addresses, you can proceed to wire the whole system together.

Connecting the AC Power Input

The AC supply to the drive can range for 90VAC RMS to 260VAC RMS, 50 to 60 Hz, single or three phase.

The AC input voltage is the most significant attribute of the AC input to affect the power that is available from the drive. At lower AC inputs the DC bus voltage is reduced and therefore will limit performance of higher voltage AC servo motors. As a general rule AC inputs of 120VAC will permit continuous operation of 500 Watt servo motors while AC inputs of 240VAC will operate 1K Watt servo motors. It is wise to match as closely as possible the AC input and the Servo Motor voltage rating.

AMP has a number of servo motors designed to operate at both 120 and 240VAC input (See [Recommended Motors](#) later in this manual.)

When available three phase input is recommended for its lower ripple on the DC bus voltage. This saves wear and tear on the DC bus capacitors and spreads out the current on the AC input rectifiers.

WARNING: Exceeding the DC Bus voltage of 367VDC may cause the internal regeneration circuitry to activate. This may result in a drive fault or some cases can result in drive failure.

24 Volt Controller Input (Keep Alive)

The BLUAC5 servo drives offer a 24 volt input that will supply “Keep Alive” power to the controller section of the drive. AC power can be removed without shutting down the servo controller. This function can be used to maintain motor position information. When AC power is restored to the drive the servo motor can be re-enable and the original position reestablished.

When 24 volt input is present and the AC input is removed the drive will display a “U” error code.

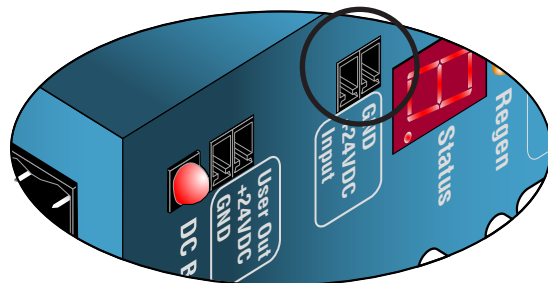

Connecting Single Phase AC input (90-260VAC)

Connect Earth (Green) to "G"
"Hot" (Black) to "L1"
"Neutral" (White) to "L2/N"

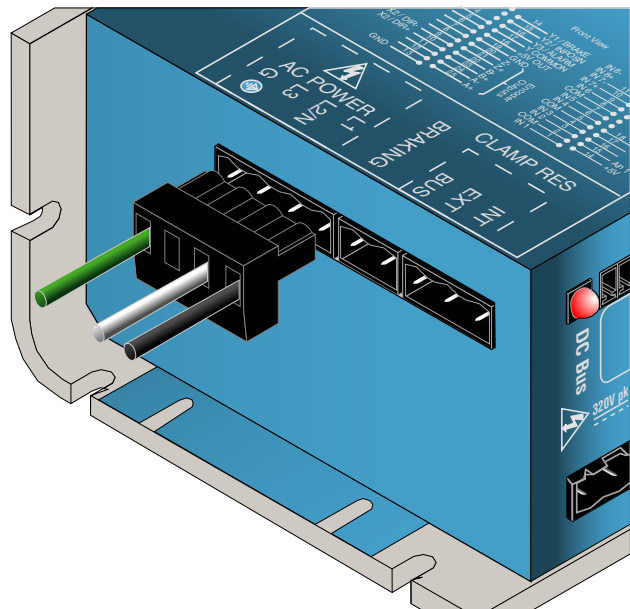

Connecting 3-Phase AC input (90-260VAC)

Connect Earth (Green) to "G"
"Phase 1" (Black) to "L1"
"Phase 2" (White) to "L2"
"Phase 3" (Red) to "L3"

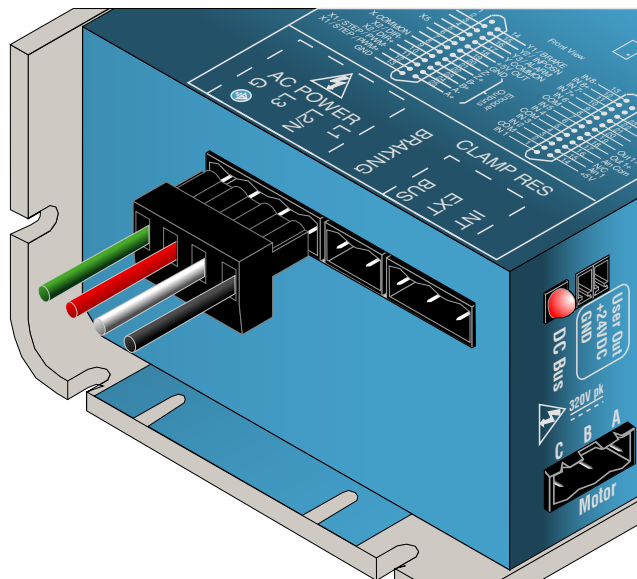

Connecting the Motor

WARNING: Never connect or disconnect the motor while the power is on.

Applied Motion Products motor:

To connect an Applied Motion servo motor to your BLU Servo, you'll need a set of mating cables called the BLUENC and the BLUMTR-FA.

You must use the "FA" (filtered) motor cable for proper operation of the drive. The green wire of the cable must be connected to the chassis ground screw of the BLuAC5.

Connect the small motor connector to one end of the motor cable. The other end of the BLUMTR-FA has lead wires that connect to the drive's screw terminal connector as follows:

A = red wire

B = white wire

C = black wire

Connect the green wire and the bare "drain" wire to the chassis ground screw.

Connect the large motor connector to one end of the BLUENC cable. The other end of the BLUENC plugs into the BLU servo.

For J-Series motors, use 3004-301-3M and 3004-307-3M cables (one of each).

Non-Applied Motion motor:

Connect the motor leads to the screw terminal connector as follows:

A = motor phase A, R or U

B = motor phase B, S or V

C = motor phase C, T or W

Connect the ground wire to the chassis ground screw.

For proper drive operation, you must use a well shielded, properly grounded cable. Ferrite filtering is highly recommended and is essential if your application is intended to comply with EMC directives such as the CE Mark. Please contact Applied Motion Products for technical advice before connecting a non-Applied Motion motor.

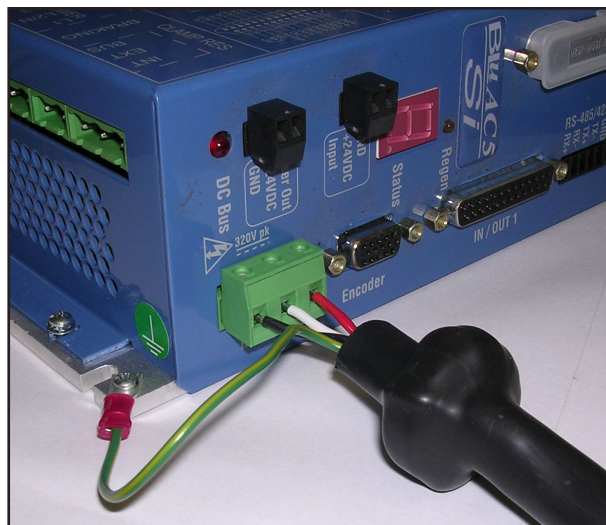

Recommended Ferrite Core Instructions

At the drive end of the leads, you must twist the power wires, and wrap those wires through ferrite cores. 4 foot cables require one ferrite with the twisted power wires running through the core 5 wraps. Longer cables require less turns through the cores, but more cores stacked together as one. In the case of a 10 foot cable, use two ferrite cores stacked as one, and three wraps. For a 20 foot cable - 3 ferrite cores stacked as one, with three turns through the cores. You may contact Applied Motion Products for technical advice if needed.

Fuses - External and Internal

External Recommended Fuses:

- recommend Time Lag 6.3A
- Littelfuse 21506.3P (cartridge type, RoHS)
- Littelfuse 21506.3XEP (axial lead type)

Internal Fuses:

Our internal fuses are 6.3 Amp, slo-blow, use same or smaller for installation ahead of the drive.

If you choose to use a circuit breaker ahead of the drive instead of using slo-blow fuses, we recommend a surge rated 7.5 to 8.0 Amp circuit breaker.

Line Filters

We recommend Leviton 51000 series surge protection modules, which provide maximum protection under all conditions. The Leviton modules are required for CE compliance. Corcom 10VR1 filters may be considered for non-CE compliant applications.

Surge Protector with Line Filter:

For 120VAC: Leviton 51010-WM

For 220VAC: Leviton 51240-WM

Connecting the Encoder & Hall Sensors

Encoder Pinout

The encoder connections use an HD-15 connector. For an Applied Motion A, N or M series motor, you'll want to use one of our BLUENC cables. For J-Series motors, use 3004-301-3M and 3004-307-3M cables (one of each).

If you are using another supplier's motor, you'll have to make your own cable according to the pinout below. See the [Mating Connectors](#) section for mating connector information. When connecting the Encoder and Hall sensors use high quality shielded cables. Connect cable shield to HD-15 connector housing.

The BLuAC5 servo drive is designed for "Differential" inputs on both the encoder signals and hall sensors. It is highly recommended that encoders with "Differential Line Drivers" be used to provide maximum noise immunity. Using the BLUENC cable with AMP servo motors provides the best opportunity for minimizing connection problems.

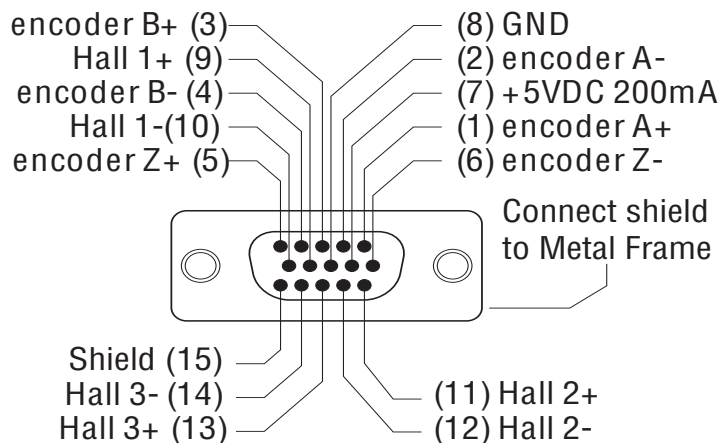

Connecting a Single-Ended Encoder

Single-ended encoders may be connected to the servo drive as shown below. In some cases this may cause loss of encoder data. Typically single ended encoders source impedance is high and cannot drive a terminated transmission line. Because of this single-ended signals may be more susceptible to “Ground” and induced noise.

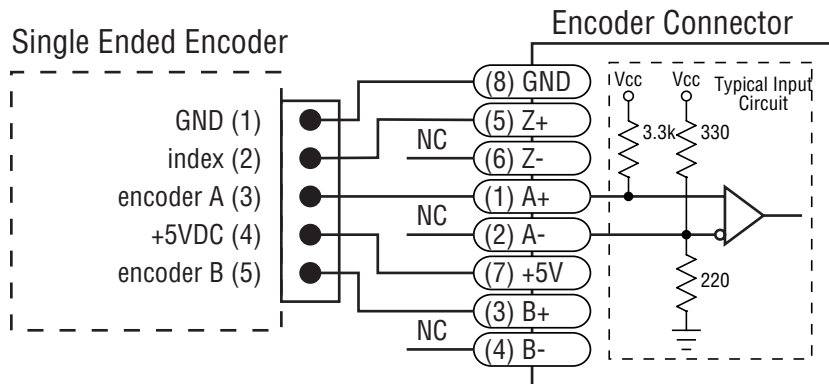

NOTE: Not recommend in “High Noise” environ-

Connecting Single-Ended Hall Sensors

Single-ended Hall sensors may be connected to the servo drive as shown below. The output of the Hall sensors must be able to “sink” 10ma of current in order to properly drive the hall sensor inputs. Typically “Open Collector outputs are best suited to driving the hall sensor inputs.

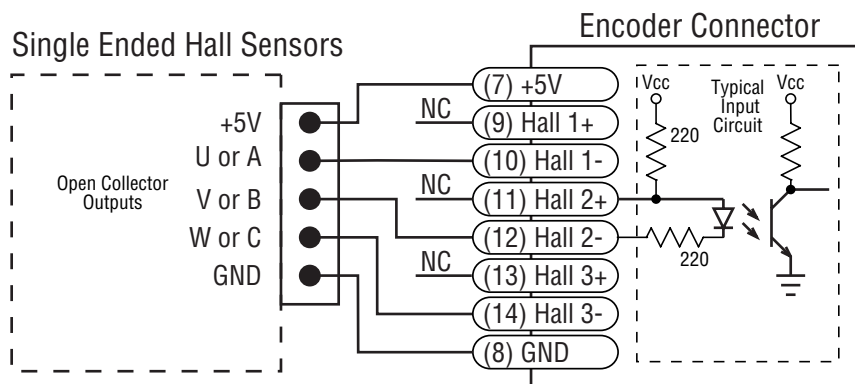

NOTE: Not recommend in “High Noise” environments

IN/OUT 1 Connector

The BLuAC5-S and BLuAC5-Q servo drives have seven digital inputs, one analog input and three digital outputs located on the IN/OUT 1 connector. All inputs and outputs are programmable using the *Quick Tuner* software. They can also be configured “on the fly” using SCL or Q commands.

Summary of Input Signals

X1/STEP & X2/DIR: digital 5V differential inputs for commanding position or encoder following.

X3 - X7 are 12-24V single ended inputs:

X3/Servo Enable: Enables and disables the motor and servo system. Can be programmed for active closed or active open. *Note: When connected to Quick Tuner this input can be overridden by the software.*

X4/Alarm Reset: Close this signal momentarily to reset a drive fault (alarm).

X5: general purpose programmable input

X6/CCWLIM & X7/CWLIM: can be used to inhibit motion in a given direction, forcing the motor and load to travel within mechanical limits.

Analog In: $\pm 10V$ analog torque, velocity or position command signal. Can also be configured for +10V, +5V or $\pm 5V$ signals.

BLuAC5-SE and -QE drives provide an additional 8 digital inputs and one analog input on the [IN/OUT 2 connector](#).

IN/OUT 1 Connector Pin Diagram

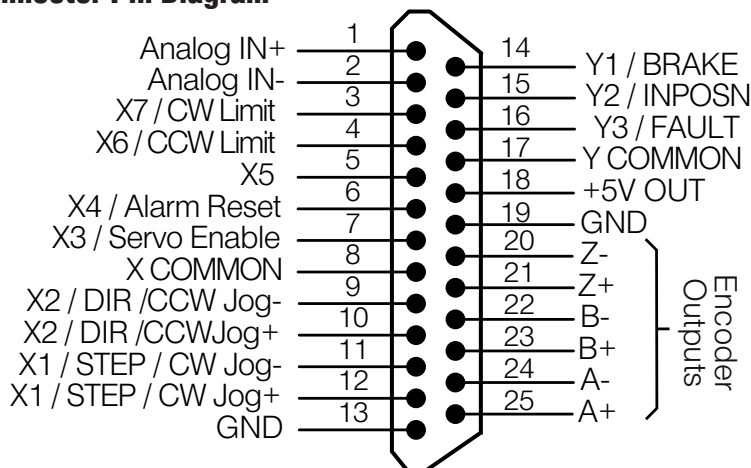

High Speed Digital Inputs

The BLUAC5 drives include two high speed inputs called STEP and DIR. They accept 5 volt single-ended or differential signals, up to 2 MHz. Normally these inputs connect to an external controller that provides step & direction (or step cw and step ccw) command signals. You can also connect a master encoder to the high speed inputs for following applications.

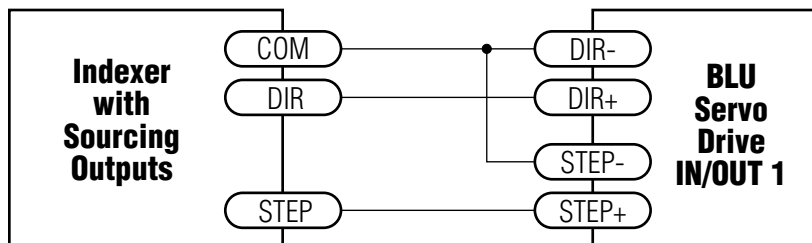
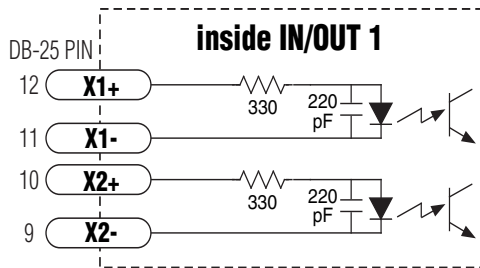

Connecting to Indexer with Sourcing Outputs
(includes many PLCs)

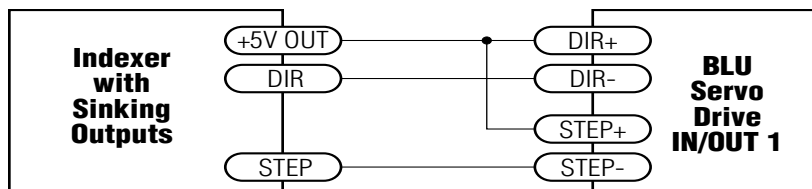

Connecting to Indexer with Sinking Outputs
(includes Applied Motion Si-1 Indexer)

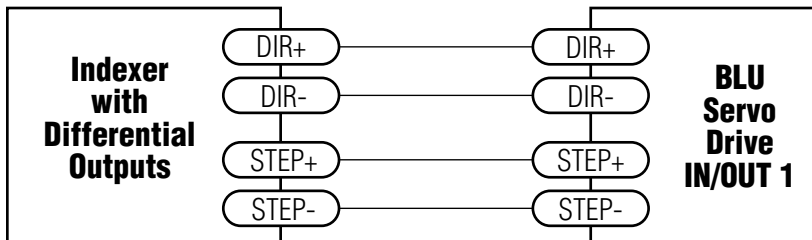

Connecting to Indexer with Differential Outputs
(includes Applied Motion Si-100 Indexer)

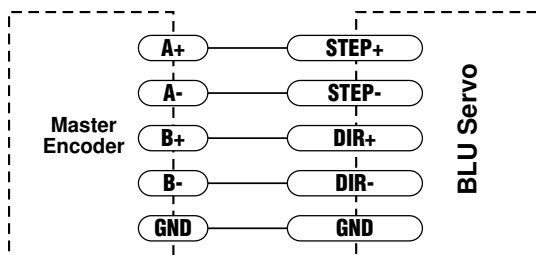

Connecting to a Master Encoder
(for following applications)

Using High Speed Inputs with 12-24 Volt Signals

Most PLCs don't use 5 volt logic. You can connect signal levels as high as 24 volts to the STEP and DIR inputs if you add external dropping resistors, as shown below.

- For 12 volt logic, add 820 ohm, 1/4 watt resistors
- For 24 volt logic, use 2200 ohm, 1/4 watt resistors

WARNING: The maximum voltage that can be applied directly to a high speed input terminal is 5 volts. Never apply high voltage AC to an input terminal.

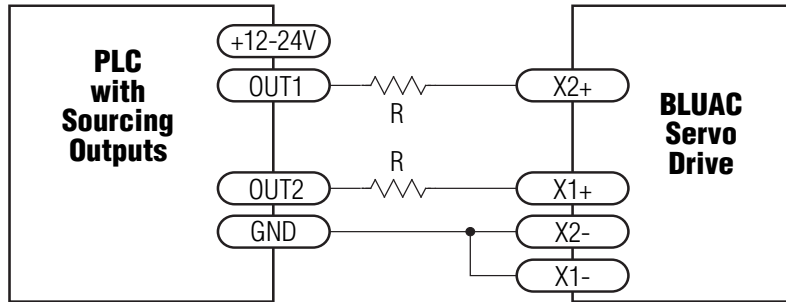

Connecting to PLC with Sourcing (PNP) Outputs

(Most PLC's use 24 volt logic)

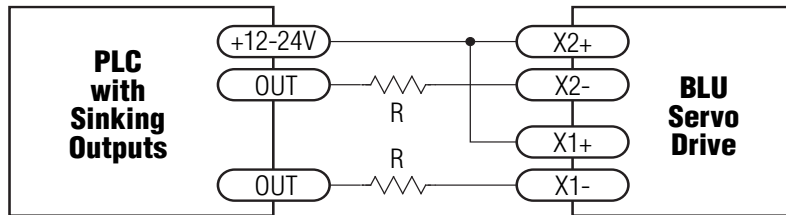

Connecting to PLC with Sinking (NPN) Outputs

(Most PLC's use 24 volt logic)

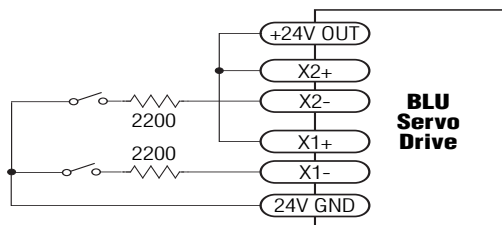

Using Mechanical Switches at 24 Volts.

Standard Digital Inputs

As we mentioned in the previous section, the high speed STEP/PWM and DIR inputs are configured for five volt logic. All other five digital inputs are designed for operation between 12 and 24 volts DC. They are single ended, optically isolated input circuits that can be used with sourcing or sinking signals, 12 to 24 volts. This allows connection to PLCs, sensors, relays and mechanical switches. Because the input circuits are isolated, they require a source of power. If you are connecting to a PLC, you should be able to get power from the PLC power supply. If you are using relays or mechanical switches, you will need a 12-24 V power supply. This also applies if you are connecting the inputs to the programmable outputs of another Si product from Applied Motion.

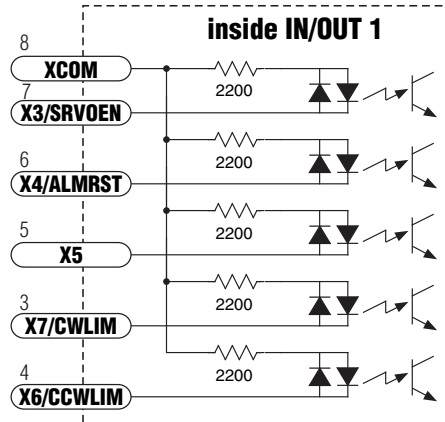

What is COM?

“Common” is an electronics term for an electrical connection to a common voltage. Sometimes “common” means the same thing as “ground”, but not always. In the case of the BLU Servo, if you are using sourcing (PNP) input signals, then you will want to connect COM to ground (power supply -). If you are using sinking (NPN) signals, then COM must connect to power supply +.

User Out 24V supply

The BLUAC5 has a 24 Volt 100ma isolated output that can be used for powering Digital Inputs or outputs. This convenient power supply can be used in place of an external supply.

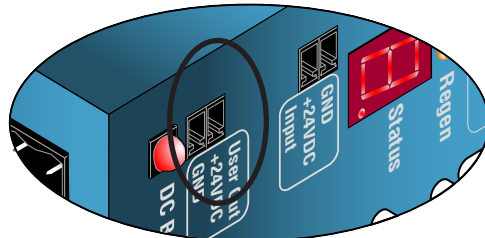

Note: If current is flowing into or out of an input, the logic state of that input is low or closed. If no current is flowing, or the input is not connected, the logic state is high or open.

The diagrams on the following pages show how to connect the inputs to various commonly used devices.

Digital Input Connection Examples

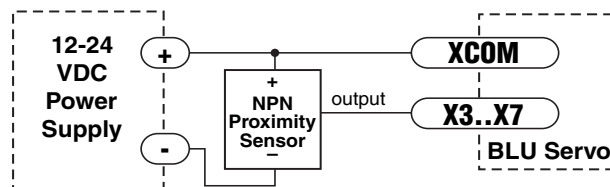
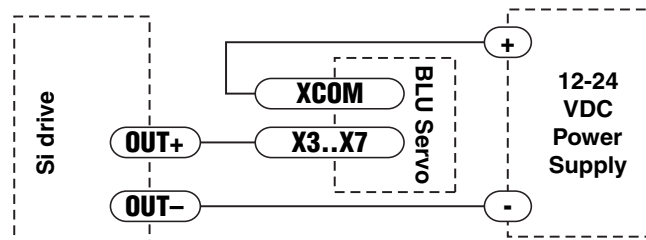
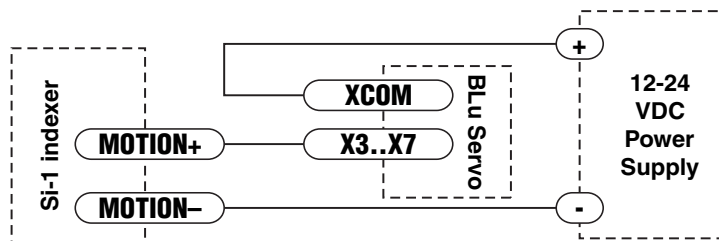
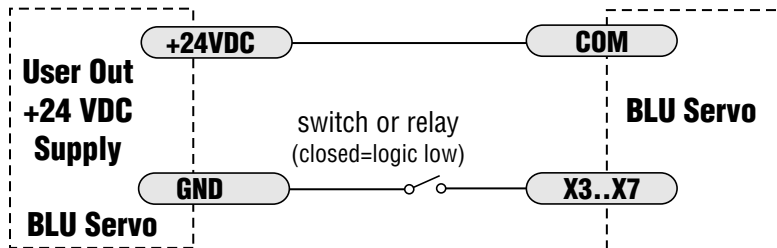

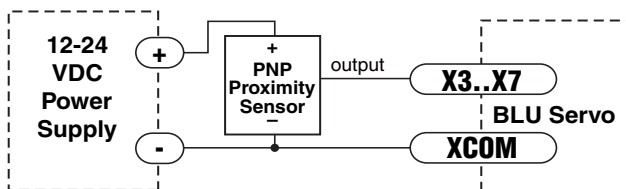

Connecting Limit Switches to the BLUAC5 Drives

The CWLIMIT and CCWLIMIT inputs are used for connecting end of travel sensors. By connecting switches or sensors that are triggered by the motion of the motor or load, you can force the motor to operate within certain limits. This is useful if a program or operator error could cause damage to your system by traveling too far.

The limit inputs are optically isolated. This allows you to choose a voltage for your limit circuits of 12 to 24 volts DC. This also allows you to have long wires on limit sensors that may be far from the drive with less risk of introducing noise to the drive electronics. The schematic diagram of the limit switch input circuit is shown below.

BLuAC5 Limit Input diagram

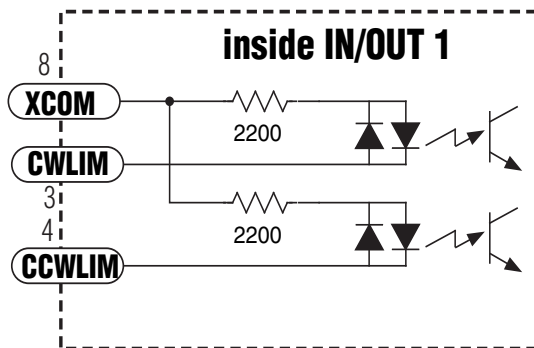

Wiring a Mechanical Limit Switch

You can use normally open or normally closed limit switches. Either way, wire them as shown here.

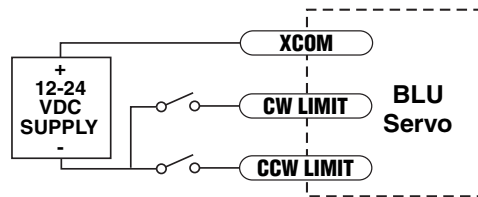

Wiring a Limit Sensor

Some systems use active limit sensors that produce a voltage output rather than a switch or relay closure. These devices must be wired differently than switches.

If your sensor has an open collector output or a sinking output, wire it like this:

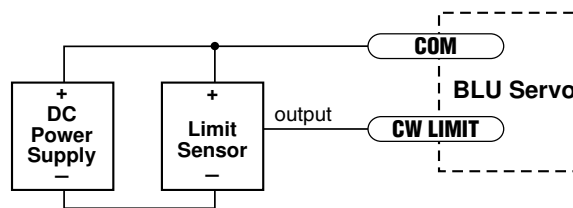

If the sensor output goes low at the limit, select the option “closed” (in the software). If the output is open, or high voltage, choose “open”.

Other sensors have sourcing outputs. That means that current can flow out of the sensor output, but not into it. In that case, wire the sensor this way:

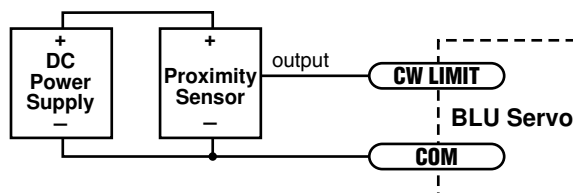

Analog Inputs

The BLuAC5 has two ± 10 Volt analog inputs that can be used individually as single ended inputs or differentially as one input. Analog inputs are used by the servo drive for a number of dedicated purposes for controlling the servo or they can be used as general purpose analog signals.

Single Ended Input

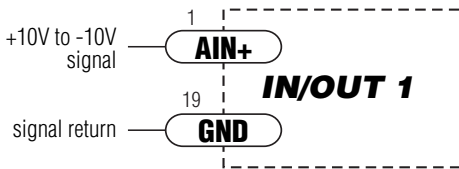

Differential Input

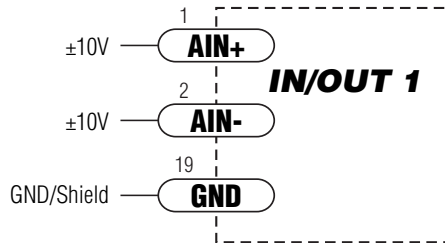

Three dedicated purposes:

- **Analog Torque Mode**
- **Analog Velocity Mode**
- **Analog Positioning Mode.**

Each of these three modes uses the analog input(s) for “commanding” the servo drive.

An analog signal can be also used to stop a “Feed to Sensor” move or to trigger a “Wait on Input”. The analog inputs can be read as variables in the SCL and Q languages and then used to set nearly any drive parameter.

Basic Specifications:

- Each input can accept ± 10 volts.
- The inputs have an impedance of 20K ohms.
- Because of the nature of the design, will exhibit a 1.4V offset when not driven by an analog source.
- Low source impedance is important for minimizing analog errors, 100 ohms or lower is recommended.

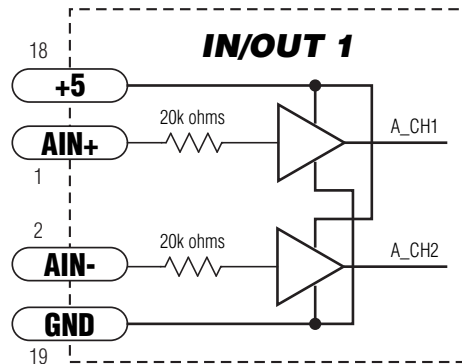

WARNING - Analog inputs must be used with care, they are not optically isolated and may not operate properly or could be damaged when system grounds are not compatible.

Wiring a controller with differential output as a singled ended input

If both inputs are to be used for different purposes differential outputs can be connected to a single input:

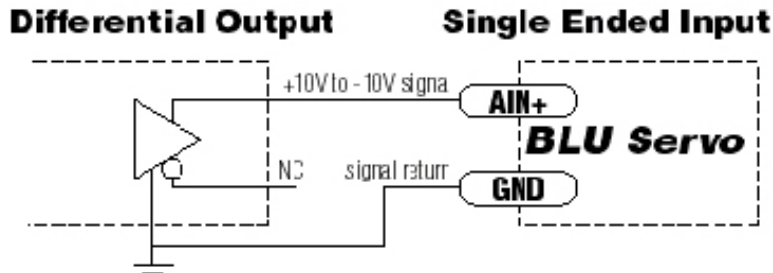

Wiring a controller with differential output to differential input

Care must be taken here to establish a good ground connection. The system ground in this case can be used for the cable shield.

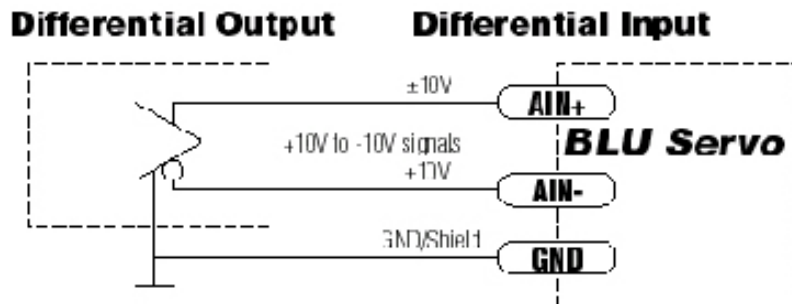

Wiring a potentiometer to a singled ended input

The +5Volt power supply from the servo drive should be used to minimize ground and voltage difference effect.

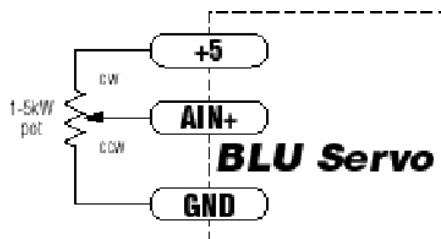

Programmable Outputs

The BLUAC5 drives feature three digital outputs:
Y1/Brake: controls an electric brake relay, automatically releasing and engaging as the drive requires
Y3/Fault: closes when a drive fault condition occurs. The red and green LEDs will flash an error code.
Y2/In Position: indicates that the drive has achieved a desired goal, such as a target position.

The BLUAC5-SE and -QE have four additional programmable outputs, located on the [IN/OUT 2 connector](#).

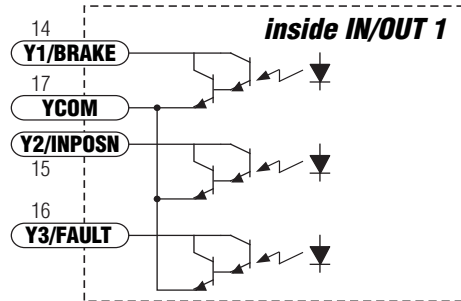

The outputs can be used to drive LEDs, relays and the inputs of other electronic devices like PLCs and counters. The Y1/BRAKE, Y3/FAULT and Y2/INPOSN outputs can only sink current. The YCOM terminal must be tied to power supply (-).

Diagrams for various connections follow.

Do not connect the outputs to more than 30VDC.
The current through each output terminal must not exceed 100 mA.

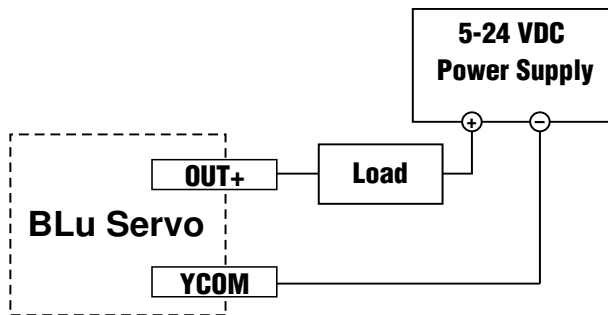

Sinking (High Side) Load

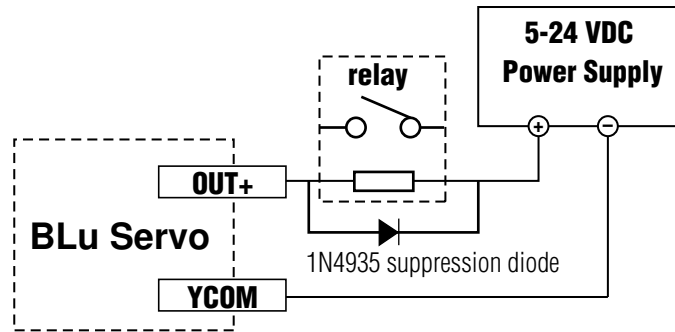

Driving a Relay (Protective Diode Required)

Encoder Outputs

In some applications you may wish to read the encoder signals being generated by the motor, may be to feed to another drive set in following mode. The DB-25 I/O connector includes encoder output signals for this purpose. The outputs are “Differential Line Driven” signals that provides buffering from the source encoder signals.

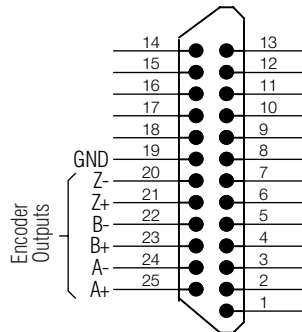

Front View

Encoder Outputs (IN/OUT 1 Connector)

IN/OUT2 Connector (-SE and -QE only)

The BLUAC5-SE and the BLUAC5-QE have a second DB-25 I/O connector labeled IN/OUT 2. This provides:

- 8 optically isolated digital inputs IN1 - IN8
- 4 optically isolated digital outputs OUT1 - OUT4
- one 0 - 5 volt analog input, 10 bit ADC resolution

IN/OUT 2 -SE and -QE only

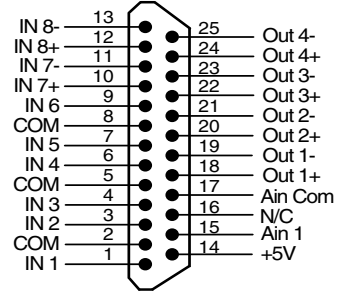

Single Ended Inputs

IN1 - IN6 are single ended, 12 - 24V inputs. They can, as a group, be configured to accept current sourcing (PNP) signals by tying one of the COM terminals to the return of the I/O power supply. If the COM terminals are connected to the + I/O power supply then the inputs 1 - 6 will accept sinking (NPN) signals. Because the input circuits are isolated, they require a source of power. If you are connecting to a PLC, you should be able to get power from the PLC power supply. If you are using relays or mechanical switches, you will need a 12-24 V power supply. This also applies if you are connecting the inputs to the programmable outputs of another Si product from Applied Motion.

Differential Inputs

IN7 and IN8 are differential, 12 - 24V inputs. They can individually be configured to accept current sourcing (PNP) or current sinking (NPN) signals.

Note: If current is flowing into or out of an input, the logic state of that input is low or closed. If no current is flowing, or the input is not connected, the logic state is high or open.

The diagrams on the following pages show how to connect the inputs to various commonly used devices.

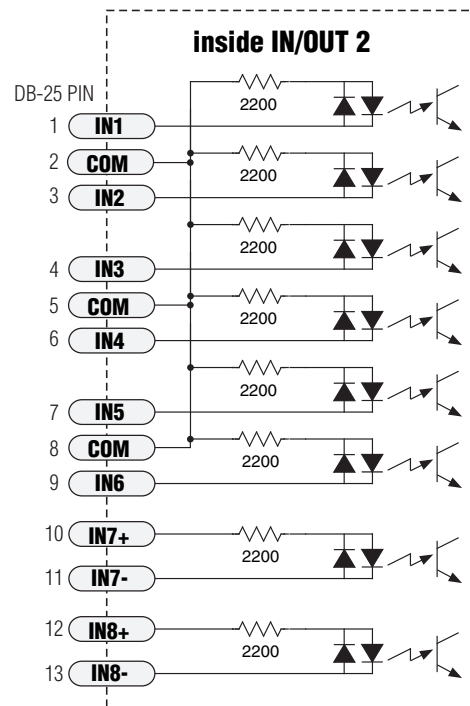

Connecting to the Analog Input on the IN/OUT 2 Connector

The analog input on the IN/OUT 2 connector can be used by “Feed to Sensor” commands and other input functions when operating the drive in “Host” mode. The analog input can also be read back to the “Host” using the “IA3” immediate command. Readings are in Volts. See “BLu Servo Host Command Reference” for more information.

+5 volt DC is provided for powering potentiometers. A 1000 to 10000 ohm potentiometer is recommended and should be connected as shown below.

A 0 to 5 volt analog signal may also be used. Usually this signal comes from a PLC, a PC with data acquisition card or a motion controller. Connections are shown below.

The +5V terminal is an output. Do not connect it to a power supply.

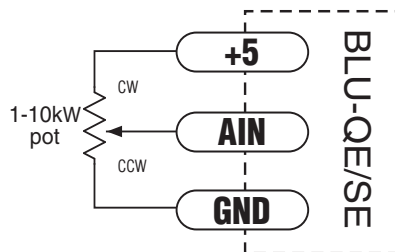

Connecting the Analog Input to a Potentiometer

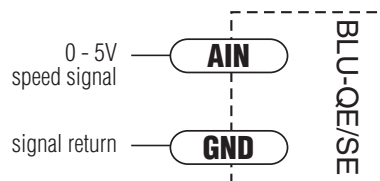

Connecting the Analog Input to an Active Signal

Programmable Outputs on the IN/OUT 2 Connector

The IN/OUT 2 connector provides four additional programmable outputs, OUT1 - OUT4.

The outputs can be used to drive LEDs, relays and the inputs of other electronic devices like PLCs and counters. The "+" (collector) and "-" (emitter) terminals of each phototransistor are available at the connector. This allows you to configure each output for current sourcing or sinking.

Diagrams for various connections follow.

**Do not connect the outputs to more than 30VDC.
The current through each output terminal must not exceed 100 mA.**

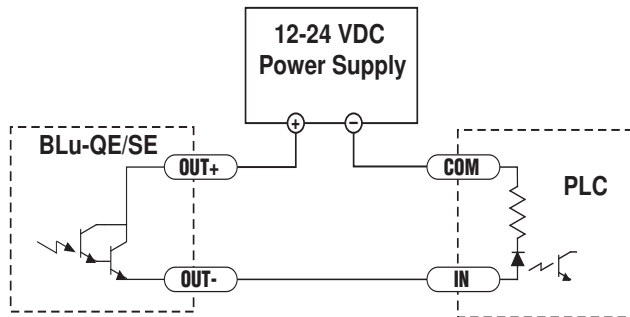
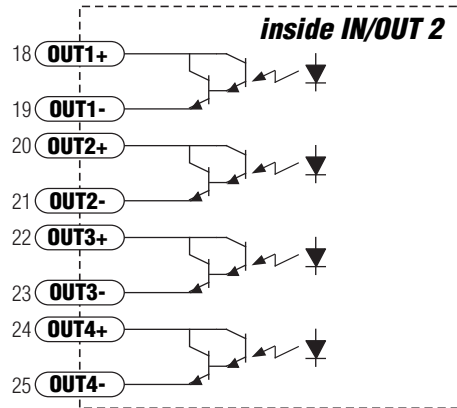

Connecting an IN/OUT 2 output to a PLC

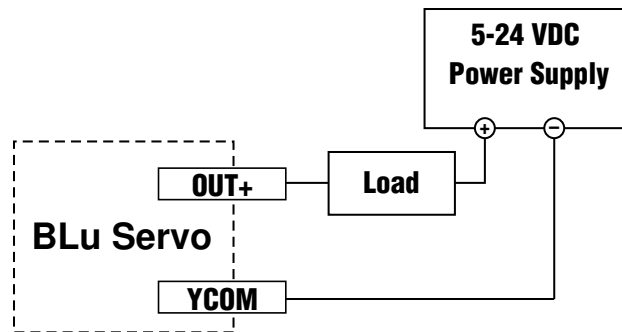

Sinking (High Side) Load

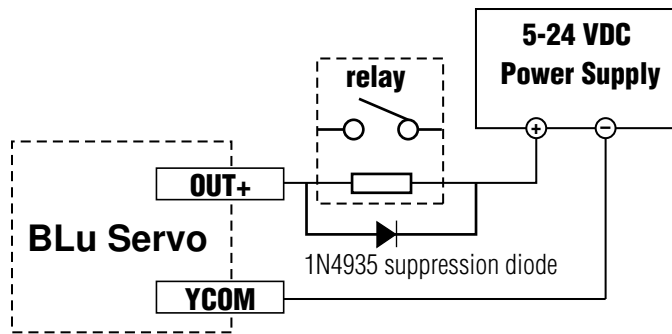

Driving a Relay (Requires Protective Diode)

Recommended AMP Motors

Alpha A Series

Part Number	Current amps	Power Watts	Volts	Size mm
A0400-101-4	5.2A	400	100	60
A0400-102-4	3.2A	400	200	60
A0600-102-5	4.2A	600	200	80
A0800-102-5	4.6A	800	200	80
A0950-103-5	4.5A	950	200	80

M Series

Part Number	Current amps	Power Watts	Volts	Size mm
M0400-101-4	5.6A	400	100	60
M0400-102-5	2.7A	400	200	80
M0600-102-5	4.5A	600	200	80
M0750-102-5	4.9A	750	200	80

N Series

Part Number	Current amps	Power Watts	Volts	Size NEMA
N0400-101-B	5.6A	400	100	23
N0400-102-C	2.7A	400	200	34
N0600-102-C	4.5A	600	200	34
N0750-102-C	4.9A	750	200	34

J Series

Part Number	Current amps	Power Watts	Volts	Size mm
J0100-301-3	1.65A	100	120/220 VAC	40
J0200-301-4	2.8A	200	120 VAC	60
J0200-302-4	1.4A	200	220 VAC	60
J0400-301-4	5.5A	400	120 VAC	60
J0400-302-4	2.7A	400	220 VAC	60
J0750-302-5	4.5A	750	220 VAC	80

Note: to connect AMP motors to a BLU servo drive, an extension cable is required. They are available in lengths of 4, 10 and 20 feet. Please contact your distributor or call the factory to order.

Other Supplier's Motors

If you want to use a motor other than those recommended here, it must be a three phase motor with 120° commutation timing. The motor must also have an incremental encoder (index signal is not required) with no fewer than 50 lines and no greater than 32,000 lines. The halls and encoder must operate from +5VDC, 200 mA max (supplied by the BLU drive). The hall signals may be single-ended or differential. We strongly recommend that the encoder have differential line driver outputs, but single-ended may be acceptable if you use a shielded cable.

If using other motors than AMP's you will need a ferrite bead on each motor lead, with the wire wrapped several turns - please refer to the section on wiring ferrites, page 17, or call an Applied Motion Products service representative.

The BLU servo drives feature sine commutation, which makes motors run more smoothly than trapezoidal drives. *If you choose a low cost motor with internal hall effect devices instead of a quality motor with precision commutation tracks on the encoder disk, your performance may suffer.*

Setting Drive Current Limits

The BLUAC5 allows the user to set both the Motor Continuous and Peak current limits. Current settings are an RMS value. Using the QuickTuner™ the current settings can be uploaded and downloaded.

Setting the current limits requires the user to know the limitations of the motor. In most cases referring to the motor manufacturers specification will give the proper information. For AMP motors, motor settings are available in parameter files that are located on the PC where QuickTuner™ was installed.

What is “Peak Current Limit”?

The BLUAC5 uses this current value to establish the maximum possible RMS current that will be driven to the motor. The peak current time is set to one second. That is, if the drive attempts to run at peak current for more then one second it will fold back the current to the continuous current setting.

The peak current time is actually calculated on a curve using an I^2/T method. For current values that are less than the peak but greater than the continuous, the current foldback time is calculated from the peak and continuous settings. As shown in the diagram below, current values below the peak value can be used for longer periods of time.

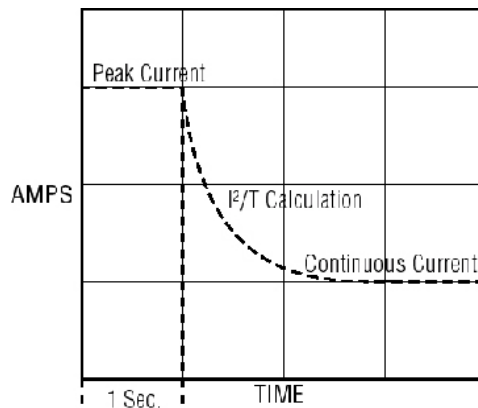

Using DC Brushed Motors

DC Brushed motors can be used with the servo drive simply by connecting the motor and encoder to the drive as show below and configuring the drive using the AMP Quick Tuner™ configuration tool.

Before connecting the Brushed motor to the servo drive you need to determine the motors polarity. That is, we need to know which wire is positive and which is negative. When applying DC power to the motor it needs to spin clockwise. After determining this, the wire connected to the positive of the DC power should be labeled at such.

Connecting the wires as shown. Positive to “A” phase and negative to “B” phase.

If an Encoder is being used Connect the Motor’s Encoder as explained earlier in this manual.

Using *QuickTuner™*, select “Brush Motor” on the “Motor - Encoder” tab. Remember to set the counts per turn in the “Encoder” setting. If the encoder is “Single Ended” be sure and check the box.

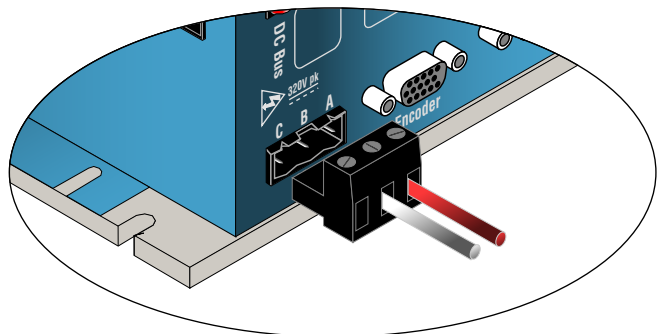
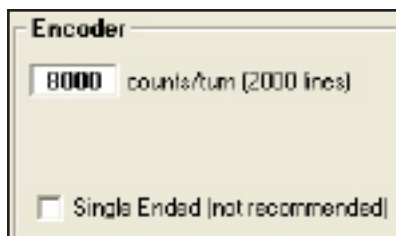
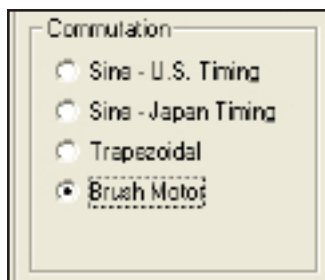

Servo Drive Regeneration

The BLuAC5 servo drive comes with a regeneration clamp circuit and power dump resistor built in. The circuit is designed to handle any power level that the drive is able to put out but the internal power dump resistor is not.

The internal power resistor is rated at a continuous 50 watts. This may not be adequate in cases where the load has a high inertia content and very little frictional content. For these cases, an external power resistor may be connected to the drive. The minimum size should be 40 ohms, 50 Watts. A typical value is 50 ohms, 100 Watts. When using an external power resistor the regeneration parameters must be changed using the *QuickTuner™* configuration tool. See example below.

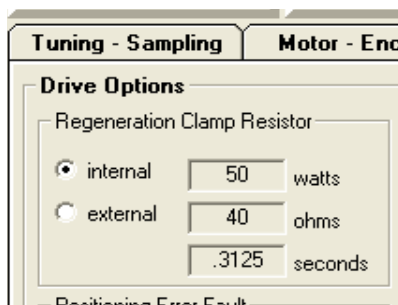
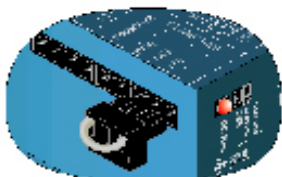

We offer an external regeneration resistor assembly specifically designed for the BLuAC5. The part number is RA-100, See page 44 for details.

Now comes the first question. How do I know if an external power resistor is needed?

There are two methods:

1. Calculation - Based on your load and operating conditions you can calculate the power in watts that will be regenerated. (*I know everybody will choose this method*)
2. Trial & Error - After operating the system the drive faults and displays a "Regen" error (small "r"). Keep sizing up the resistor until it can withstand the regeneration.

And the second question is - How do I hook it up? See the diagram below.

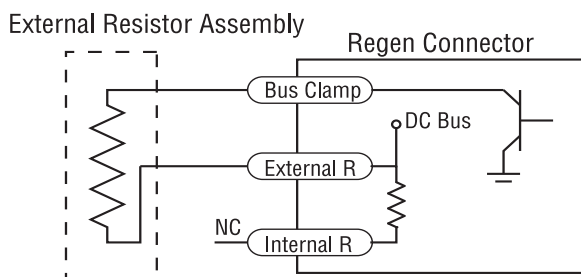

Wiring Integral Holding Brakes

The integral holding brakes of AMP servo motors require between 200 and 400 mA at 24 VDC to operate properly. To wire and operate a holding brake from the Y1/Brake output of an Applied Motion servo drive requires the following items:

- A 24 VDC power supply with minimum output of 450 mA
- A 24 VDC relay*
- A clamp diode such as 1N4935*
- An AMP servo motor with integral holding brake, designated by a “5” in the 7th position of the motor part number. Example: M0400-151-4-000
- A “BK” type motor power cable or separate brake cable. Example: BLUMTR-BK-FA-10

* Relays with an integral clamp diode, like IDEC part number RU2S-D-D24, greatly simplify the wiring effort by including the relay and a clamp diode in one unit.

Following the diagram below, connect the power supply, relay, and diode to the brake leads of the servo motor, as well as the Y1/Brake output connections of the servo drive.

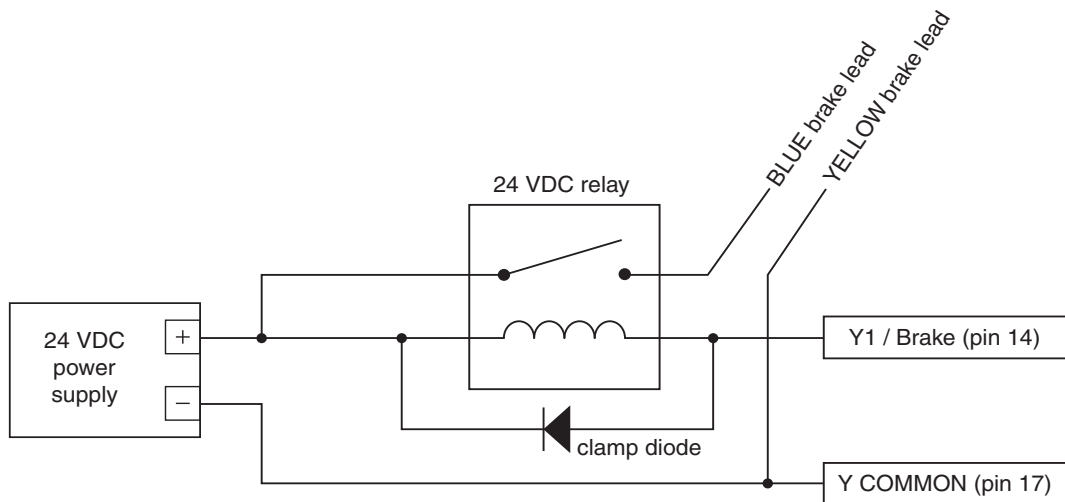

The holding brakes of M Series servo motors are fail-safe brakes, which means they are engaged when no power is applied to the brake. When setting up a servo drive in Quick Tuner, be sure to set the Brake output options in the “Inputs-Outputs” tab as shown in the diagram below. Make sure to select the check box for “Automatically release brake when moving by” and selecting the radio button “closing the Brake output”.

Brake

Automatically release brake when moving by closing the Brake output
 opening the Brake output

Wait msec before moving for brake to release

Wait msec for brake to engage before disabling servo

The engaging and disengaging of the brake is done automatically by the servo drive. When the drive is enabled and not faulted the brake will be disengaged. When the drive is disabled and/or faulted the brake will be engaged.

There are two time delays associated with the Brake output function which are also set in Quick Tuner (see diagram above). The first time delay controls how long the drive will delay a move command if the move command immediately follows the disengagement of the brake. The second time delay controls how long the drive will delay disabling the motor after engaging the brake when a motor disable command is issued.

Reference Information

Below is a summary of specifications for the integral holding brakes available with M Series servo motors.

Motor Power (W)	30	50	100	100	200	400	200	400	600	750
Motor Frame Size	NEMA 17 40 mm	NEMA 17 40 mm	NEMA 17 40 mm	NEMA 23 60 mm	NEMA 23 60mm	NEMA 23 60 mm	NEMA 34 80 mm	NEMA 34 80 mm	NEMA 34 80 mm	NEMA 34 80 mm
Rated Voltage	24 VDC									
Static Friction (in-lb)	2.83				11.24				22.5	
Input Power (W)	5		9		9		9.5		9.5	
Input Current (A)	0.2		0.375		0.375		0.39		0.39	
Armature Release Time (msec Max)	20		20		20		50		50	
Armature Pull-In Time (msec Max)	40		40		50		80		80	

Mounting the Drive

These drives can be mounted on the narrow side or the wide side. Either way, you'll need two #6 screws to secure the drive using the 0.2" mounting slots. The hole pattern and drive outline are shown below.

- **Never use your drive in a space where there is no air flow or where other devices cause the surrounding air to be more than 40 °C.**
- **Never put the drive where it can get wet or where metal particles can get on it.**
- **Always provide air flow around the drive.**

Mechanical Outline

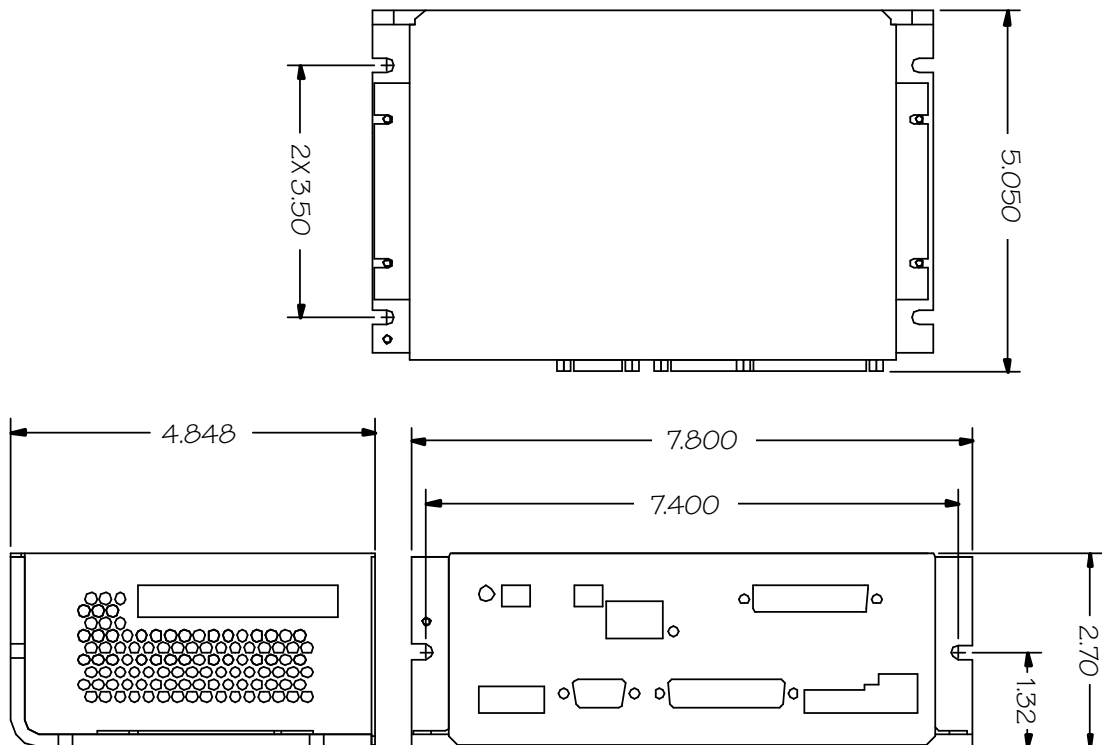

Technical Specifications

Amplifier	Sine commutation IGBT. 16 kHz PWM. 90 - 260 VAC input 5A continuous, 15A peak
Digital Inputs	Step & Direction: differential, optically isolated, 5V logic. 330 ohms internal resistance. 0.5 μ sec minimum pulse width. 2 μ sec minimum set up time for direction signal. All other digital inputs: optically isolated, 12 - 24V logic. 2200 ohms. Maximum current: 10 mA
Analog Inputs	\pm 10VDC, 12 bit ADC With Expanded I/O board: 0 to 5 VDC, 1K - 10K recommended impedance. 10 bit ADC
Outputs	Photodarlington, 100 mA, 30 VDC max. Voltage drop: 1.2V max at 100 mA.
24V Output	24VDC @ 100ma
Encoder Output	26C31 line driver
Physical	2.70 x 4.848 x 7.80 inches overall. 2 lb 3.1 oz Ambient temperature range: 0 to 40° C.

Mating Connectors and Accessories

Mating Connectors

Motor/Regen: Mating connector included. Phoenix P/N 1767012.
AC Input: Mating connector included. Phoenix P/N 1767025.
Brake: Mating connector included. Phoenix P/N 1766990.
RS-485: Mating connector included. PCD P/N ELVP05100.
I/O: DB-25 male. Mating connector included. AMP P/N 747912-2.
Shell Kit AMP P/N748678-3.
Motor feedback: HD-15 male. Norcomp P/N 180-015-102-001. Shell Kit AMP P/N 748678-1.

Accessories

Motor Cables for Applied Motion “A”, “N” and “M” series servo motors:

- BLUMTR-FA-04, four foot shielded and filtered cable
- BLUMTR-FA-10, ten foot shielded and filtered cable
- BLUMTR-FA-20, twenty foot shielded and filtered cable

Motor Cables for Applied Motion “J” series servo motors:

- 3004-307-3M, nine foot shielded and filtered cable

Encoder Cables for Applied Motion “A”, “N” and “M” series servo motors:

- BLUENC-CA-04, four foot shielded cable
- BLUENC-CA-10, ten foot shielded cable
- BLUENC-CA-20, twenty foot shielded cable

Encoder Cables for Applied Motion “J” series servo motors:

- 3004-301-3M, nine foot shielded cable

Breakout Box for IN/OUT Connectors:

- BOB-1, for IN/OUT 1, includes cable
- BOB-2, for IN/OUT 2, includes cable (sometimes known as “BABS” because it’s a female version of the BOB-1)

Screw Terminal Connectors that mate directly to the IN/OUT connectors on the front panel of the drive:

- Phoenix Contact P/N [2761619](#) (for IN/OUT 2) and [2761622](#) (for IN/OUT 1)

This connector is not available from Applied Motion.

You must purchase it from a [Phoenix distributor](#).

Mating Cable for IN/OUT connectors with “flying leads”

Black Box P/N: BC00702

This cable is not available from Applied Motion. You must purchase it from [Black Box](#).

Useful for custom wired applications. This shielded cable has a DB-25 connector on each end. If you cut it in half it will provide 3 foot “DB-25 to flying lead cables” for both IN/OUT1 and IN/OUT 2.

It’ll be easier to wire if you get the [cable color chart from Black Box’s website](#).

Surge Protector with Line Filter:

For 120VAC: [Leviton 51010-WM](#)

For 220VAC: [Leviton 51240-WM](#)

External Regen. Resistor Assembly

Specifically designed for the BLuAC5: RA-100 available from Applied Motion Products.

Applied Motion Products, Inc.

404 Westridge Drive Watsonville, CA 95076
Tel (831) 761-6555 (800) 525-1609 Fax (831) 761-6544
www.appliedmotionproducts.com