

PANEL SIDE

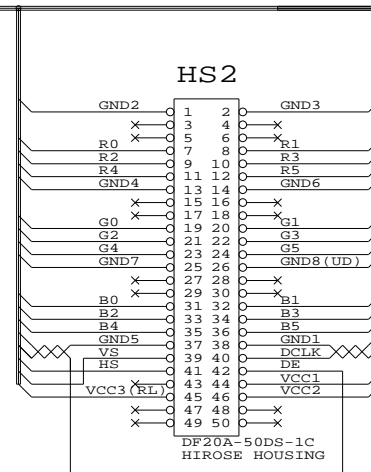
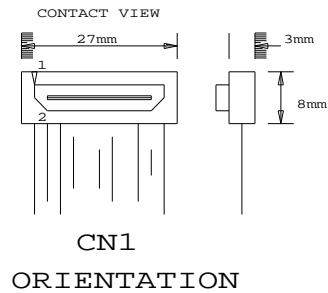
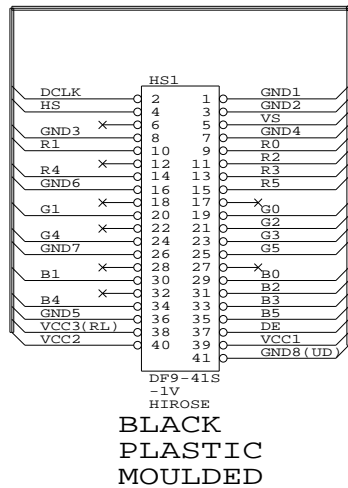

CABLE: UL20276, 17 PAIRS, 30AWG (BRAID SHIELD TYPE), PVC COLOR BLACK, COLOR CODED  
 GND6 CONNECTED TO CABLE SHIELDING WIRE  
 HS3: DCLK/GND1 & DE/GND5 MUST USE TWISTED PAIR, OTHER PAIRS ARBITRARY

REMARK: SVH-1920 VERSION OF 4263116-00

P/N 426500500-3

PANEL CABLE: SVH-1920/6880, 330mm

DIGITAL VIEW LTD.		
COPYRIGHT 2006, ALL RIGHTS RESERVED		
CONFIDENTIAL		
DRAWN BY: VICTOR NG		
Title P.CABLE: SVH-1920/6880,330mm		
Size Document Number		
B	(G:\...\DV\DV_CABLE\C6500500.SCH)	REV 00
Date:	March 13, 2006	Sheet 1 of 1